

Operating Instructions

REOVIB MTS 440/442

Thyristor controllers for vibratory feeders
With digital settings

REO (UK) LTD
Units 2-4 Callow Hill Road,
Craven Arms Business Park,
Craven Arms, Shropshire, SY70HP
Tel: 01588 673411
Fax: 01588 672718
<http://www.reo.co.uk>
email: main@reo.co.uk

REOVIB

Controllers for Vibratory Feeder Engineering

Technical Safety Information for the User

This description contains the necessary information for the correct application of the product described below. It is intended for use by technically qualified personal.

Qualified personnel are persons who, because of their training, experience and position as well as their knowledge of appropriate standards, regulations, health and safety requirements and working conditions, are authorised to be responsible for the safety of the equipment, at all times, whilst carrying out their normal duties and are therefore aware of, and can report, possible hazards (Definition of qualified employees according to IEC 364)

Safety Instructions

The following instructions are provided for the personal safety of operators and also for the protection of the described product and connected equipment.



Warning!

Hazardous Voltage

Failure to observe can kill, cause serious injury or damage

- Isolate from mains before installation or dismantling work, as well as for fuse changes or post installation modifications.
- Observe the prescribed accident prevention and safety rules for the specific application.
- Before putting into operation check if the rated voltage for the unit conforms with the local supply voltage.
- Emergency stop devices must be provided for all applications. Operation of the emergency stop must inhibit any further uncontrolled operation.
- **Electrical connections must be covered**
- **The earth connection must be checked, for correct function, after installation.**

Specified Use

The units described herein are electrical controllers for installation in industrial plant. They are designed for power adjustment on vibratory feed equipment.

Contents

Technical Safety Instructions for the User.....	
1.0 General.....	3
2.0 Function.....	4
2.1 Mechanical Frequency.....	4
2.2 Enable.....	4
2.3 Status output.....	4
2.4 Track Control.....	4
2.5 Integration Channel 1 / Channel 2.....	4
2.6 Sensor-time-out (Fault output).....	5
2.7 Solenoid output.....	5
2.8 Coarse / Fine control.....	5
2.9 Pulse operation.....	5
3.0 Running Displays.....	6
4.0 Technical data.....	7
5.0 Declaration of conformity.....	7
6.0 Adjustment parameters.....	8
7.0 Settings.....	9
7.1 Setpoint for feeder throughput.....	10
7.2 Function selection.....	10
7.3 Pulse operation.....	10
7.4 Track control - Line 1.....	11
7.5 Track control - Line 2 (only on REOVIB MTS 442).....	11
7.6 Sensor logic.....	11
7.7 Sensor Time-out.....	11
7.8 Feeder - Channel 1.....	12
7.9 Feeder - Channel 2.....	12
7.10 Parameter protection.....	13
7.11 Recall settings.....	13
7.12 Hide setting menus.....	13
8.0 Unit connections.....	14
8.1 Internal circuits.....	15
9.0 Unit dimensions.....	16
Ordering codes (Standard Units).....	16

1.0 General

The REOVIB MTS 440 range includes single and twin controllers that are used for infinite variable throughput control of vibratory feeders. The units are built into an IP54 aluminium housing that is suitable for mounting onto a vibration free part of the work station. The controller comprises a mains switch, fuses and, depending upon the version, a mains cable and output cable or input and output connectors. Input sockets are provided for sensors and status outputs.

The feeder throughput setting and adjustment of all special parameters is made through the integrated touch panel and LED display in the front panel. In addition to the coloured ON/OFF buttons the unit can be quickly enabled/inhibited, through an input, without switching the supply.

The adjustment of the feeder amplitude is achieved by using phase angle control of the mains current. Depending on the frequency of the mains voltage, the units are suitable for vibratory feeders with a mechanical frequency of:-

3000 cycles/min (50 Hz) or 6000 cycles/min (100 Hz) with a mains frequency of 50 Hz.

3600 cycles/min (60 Hz) or 7200 cycles/min (120 Hz) with a mains frequency of 60 Hz.

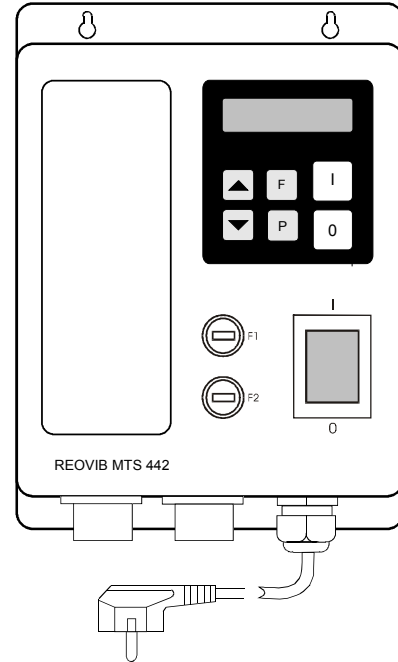

Model		REOVIB MTS 440-01	REOVIB MTS 440-02	REOVIB MTS 442-01	REOVIB MTS 442-02
Function range:					
Single control		•	•		
Twin control				•	•
Soft start	Each output, adjustable, 0...4 secs	•	•	•	•
Enable	Contact or 24V signal voltage	•	•	•	•
Mechanical frequency	switchable 3000/6000 cycles/min (50Hz supply)	•	•	•	•
Status output	24 V, DC unit status (Feeder ON/OFF)	•	•	•	•
Track control:. Channel 1 Channel 2	Component track with one or two sensors. Adjustable on and off switching time delays		•		•
Sensor input	2 Sensors 24 V, PNP		•		•
Sensor Time-out Fault output:	24 V, DC Sensor Time-out		•		•
Solenoid output:	24 V, DC e.g. for air reject		•		•
Coarse / fine control: Line 1	2 speed operation, switching from a sensor		•		•
Pulsed control	Pulsed output with adjustable times	•	•	•	•

2.0 Function

A microprocessor is used as the main control component and this is used to change all control functions. The throughput is adjusted by using phase angle control. An internal compensation circuit regulates the controller so that variations in the mains voltage have no effect on feeder throughput. All power outputs have an adjustable soft start.

2.1 Mechanical frequency

The mechanical frequency of the vibratory feeder is determined by the frequency of the mains supply and can also be changed by inhibiting a mains half-wave (3000 / 6000 cycles per minute, for 50 Hz mains). **This must be set to FULL WAVE for controlling an elevator motor.**

2.2 Enable

There are inputs for each channel which switch the controller ON/OFF internally (not the supply) from a supervisory system. A 24 V, DC signal or switch can be used. The input function is programmable. **By selecting the enable input (-En =I Set using menu "C 003".) it is possible to run without an enable signal being present.**

2.3 Status output

A 24 V, DC output for condition monitoring e.g. for integration with other control systems. The output is energised when power output is active.

2.4 Interlocking Channel 1 / Channel 2

Output channels 1 and 2 can be interlocked so that:-

- Channel 1 can be active only when channel 2 is active
- Channel 2 can be active only when channel 1 is active

Set using menu "C 003".

2.5 Track control

- Controlling a component track with a single sensor:
A single sensor can be used to regulate the store of material, on a linear feeder for example. When product has been detected by the sensor, the feeder switches off, after a preset delay time "t-off" has expired. The feeder switches back on again when there is no product detected, after a preset delay time "t-on" has expired. Every sensor signal resets the timer so that the delay always starts after the last component has been detected.
- Controlling a component track with two sensors:
One of the sensors is used to control the minimum product position and the other controls the maximum position. When product has been detected by the MAX-sensor, the feeder switches off, after a preset delay time "t-off" has expired. When the component level drops below the MIN-sensor, the feeder switches back on again, after a preset delay time "t-on" has expired.

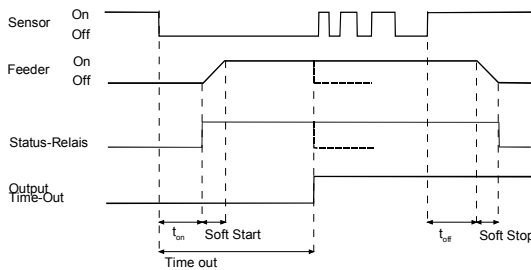

Track Control (1 Sensor)

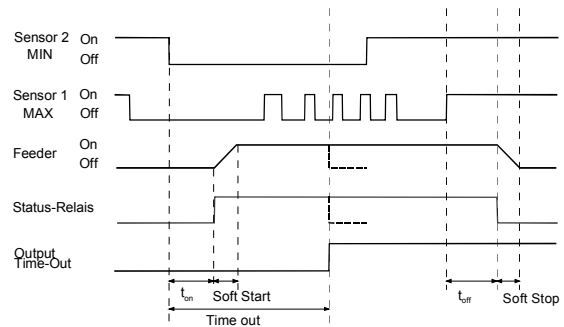

MIN / MAX Control (2 Sensors)

2.6 Sensor-time-out (Fault signal)

This function is used to monitor if components are being detected by the sensor. The power output to the feeder is switched off and a 24V signal is energised when no product has been detected by the sensor for a selected time period. The sensor time-out function has to be activated in menu "C 015".

2.7 Solenoid output

A 24V DC solenoid valve output is provided for use with an air-jet, for example. This is factory set (Air. 0 in Menu 003) to de-energise when the feeder powers down and to energise when the feeder starts up again. It is possible to introduce time delays of 1second between energising the solenoid output and powering up and 4 seconds between powering down and de-energising the solenoid output, by selecting Air. 1 in menu C003.

2.8 Coarse/fine control

A coarse/fine function can be used in place of track control. This switches the power output 1 to a second set point level on a signal from sensor 1. This can be used in weighing applications, for example, in response to a coarse/fine contact (to prevent over filling).

2.9 Pulsed output

This is used to control a hopper feeder. The power output is pulsed according to ON and OFF time settings. A motor driven bunker hopper (1-phase) can also be operated in the manner but the set point for this channel must be set to 100%. This function must be selected in menu "C004".

3.0 Operating displays

In normal operation the throughput setting for channel 1 is displayed.

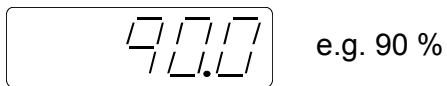

Whilst setting up, the output channel is indicated by the first display segment..

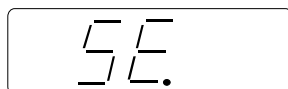
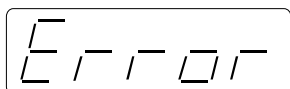
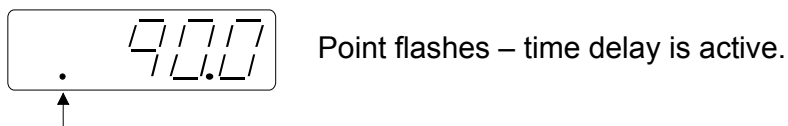
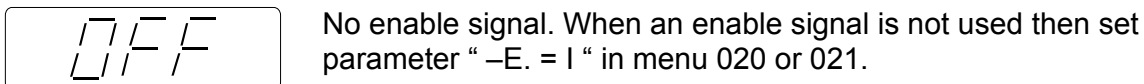
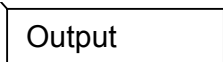
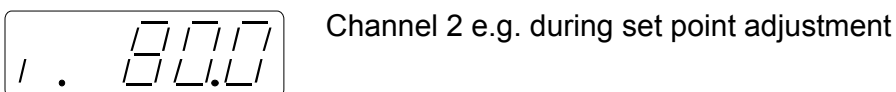
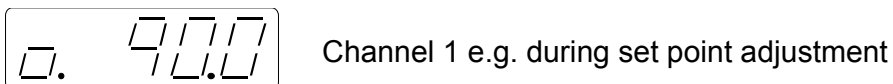

Sensor Time-out is exceeded (Menu "C 015")
Reset with "P" button

4.0 Technical Data

Unit type	REOVIB MTS 44012
Function selectable	Yes
Mains supply	110V or 230V +/- 10 %, 50/60 Hz self-setting
Power output 1	0...100 / 0...210 V, 6 A
	The total current of both outputs must not exceed 10A !
Umax	50...100% adjustable
Unit fuses	2 x 10 A, M
Construction	Aluminium housing IP 54
Operator controls	Mains switch and display with programming buttons. Power adjustment to the feeders and all parameters can be set up, externally, using the display and buttons (the unit does not have to be opened).
Soft start	Adjustable 0...4 sec., operates whenever the unit is switched on ie mains, enable and track control.
Soft stop	Adjustable 0...4 sec., operates in conjunction with track control and enable.
Enable	24 V, DC Input or contact
Solenoid output	24 V, 100 mA
Sensor supply	24 V, DC, 100 mA (total)
Sensor types	PNP only
Track control switch-on delay time	0,1...15 sec.
Track control switch-off delay time	0,1...15 sec.
Pulse control ON	0,1...15 sec.
Pulse control OFF	0,1...15 sec.
Fault time (Sensor-Timeout)	30...240 sec.
Status output	24 V, DC / 20 mA, operates in conjunction with feeder (PNP)
Operating temp.	0...+45 °C
Storage temp.	-40...+80 °C
Weight	
Dimensions WxHxD	
Standards	

5.0 Declaration of Conformity

 We declare that these products, as stand-alone equipment, conform to the following standards or subsequent documents: EN 50081-2 and EN 50082-2 in accordance with 89/336/EWG regulations.

REO ELEKTRONIK GMBH, D-42657 Solingen

6.0 Adjustment Parameters

Parameter:		Display	Factory settings	Pass code:
• Feeder amplitude Channel 1 and Channel 2		o. A. i. A.	0 %	000 / 020 / 021
• 2. Feeder amplitude (fine)	0...100 %	2.	0 %	000 / 020
• Maximum control limit (U_{max}) Channel 1	50...100 %	o. P.	90 %	020
• Maximum control limit (U_{max}) Channel 2	50...100 %	i. P.	90 %	021
• Feeder mechanical frequency 3000/6000 cycles/min (50Hz supply) Channel 1	0 / 1	o. HA.	1	020
• Feeder mechanical frequency 3000/6000 cycles/min (50Hz supply) Channel 2	0 / 1	i. HA.	1	021
• Soft start Channel 1	0...5 sec.	o. /.	0,1 sec.	020
• Soft start Channel 2	0...5 sec.	i. /.	0,1 sec.	021
• Soft stop Channel 1	0...5 sec.	o. \.	0,1 sec.	020
• Soft stop Channel 2	0...5 sec.	i. \.	0,1 sec.	021
• Invert external enable Channel 1	0 / 1	o. -E.	1	020
• Invert external enable Channel 2	0 / 1	i. -E.	1	021
• Change Channel 1 Track control or coarse/fine control	0 / 1	SP.2	0	003
• Track control switch-on delay Channel 1	0...60 sec.	o. I.	5 sec.	007
• Track control switch-on delay Channel 2	0...60 sec.	i. I.	5 sec.	006
• Track control switch-off delay Channel 1	0...60 sec.	o. O.	5 sec.	007
• Track control switch-off delay Channel 2	0...60 sec.	i. O.	5 sec.	006
• Invert sensor function PNP / PNP Inverse Channel 1	0 / 1	o. -SE.	0	007
• Invert sensor function PNP / PNP Inverse Channel 2	0 / 1	i. -SE.	0	006
• Activate sensor time-out Channel 1 and Channel 2	0 / 1	E.E.	0	015
• Fault time (Sensor Time-out) Channel 1 and Channel 2	30...240 sec.	E.	30 sec.	015
• Sensor logic AND / OR	0 / 1 0 / 1	SLU. SLO.	0 0	014
• Pulse control Channel 1 and Channel 2	0 / 1	o. HP. i. HP.	0	004
• Save user settings		PUSH.		143
• Restore factory settings		FAC.		210
• Restore user settings		US.PA.		210
• Hide program menus	0 / 1	Hd.C.	0	117

7.0 Settings

The six buttons and a LED display found in the front panel, are used for operating and setting up the unit. All operating methods and adjustable parameters can be set up through this panel.

The "I" and "O" buttons are used for switching the unit ON and OFF, however, **these do not provide mains isolation**, they simply inhibit the power semiconductors

The "P", "F" and "Cursor Buttons" are used for parameter adjustment. Parameters are set by using menu controls which are called up by entering operator codes. A capital letter is used to indicate the selected function.

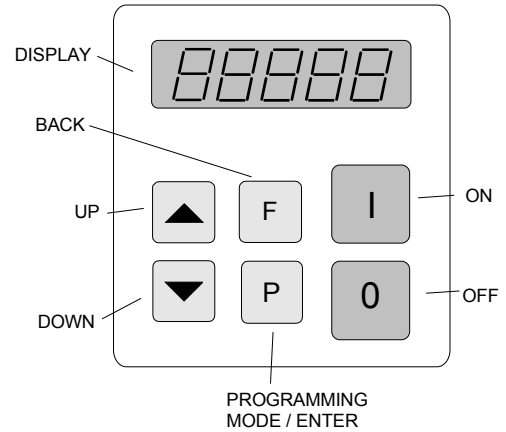

The display value can be increased or decreased by units, or tenths of units, by a short press of the cursor buttons. Holding the buttons down will cause the display to change in units of ten.

To prevent accidental or unauthorized adjustment the adjustment parameters, in the user menus, are protected. A code must be entered to open the user menus. There are different pass codes for each function group.

Setting adjustments are automatically saved upon leaving the programming mode or if no button is pressed for a period of 100 seconds.

All setting routines are commenced by pressing the programming button "P". The following diagram should clarify the sequence in which keys are pressed:-

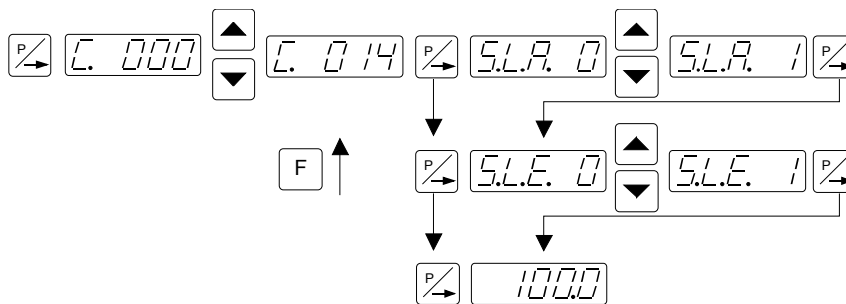

1. Press the "P" key.
2. Select the code number with the cursor keys.
3. Press the "P" key. This displays the first menu point. The required menu point can be found by repeatedly pressing the "P" key (scrolling).
4. The value in the menu point can be changed with the cursor keys..
5. Scroll to the next menu point or to the end of the menu, which returns the display to the set point value, by pressing the "P" key. To exit the menu and return back to the normal display, quickly, depress the "P" key for 5 seconds.
6. To return back to the previous position in the menu, press the "F" key.

7.1 Set point for feeder throughput

The set point can be changed in several menus.

The machine operator can change the set point, without knowing the menu codes, by pressing the "P" key twice. **The speed must be 100% for controlling an elevator motor**

Code 000 Feeder Speed

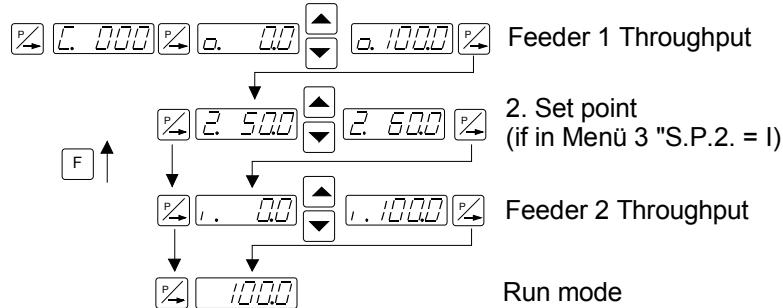

7.2 Function selection

Code 003 Selection

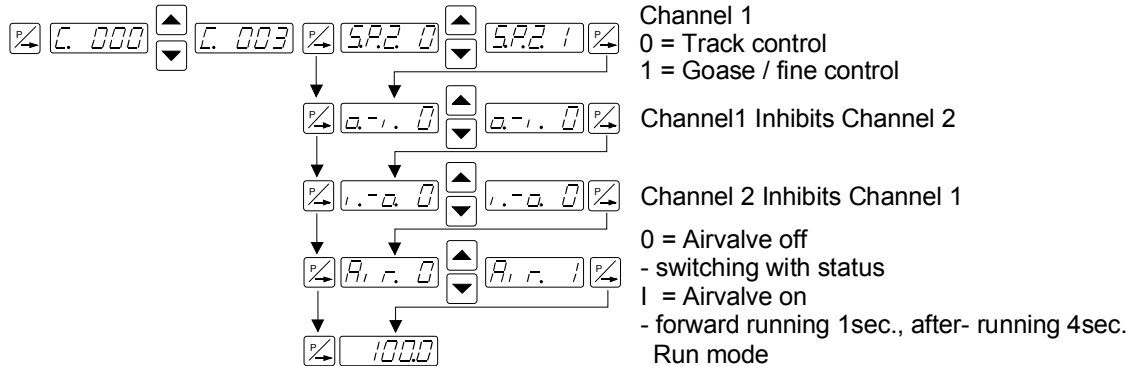

7.3 Enable Pulse Feed Function

Code 004 Pulsed Feed

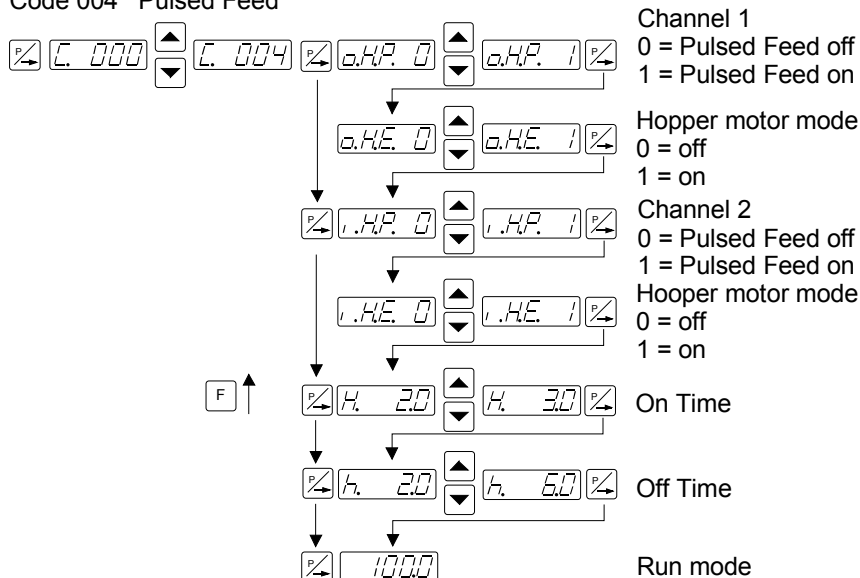

7.4 Track Control Channel 1

Code 007 Track control channel 1

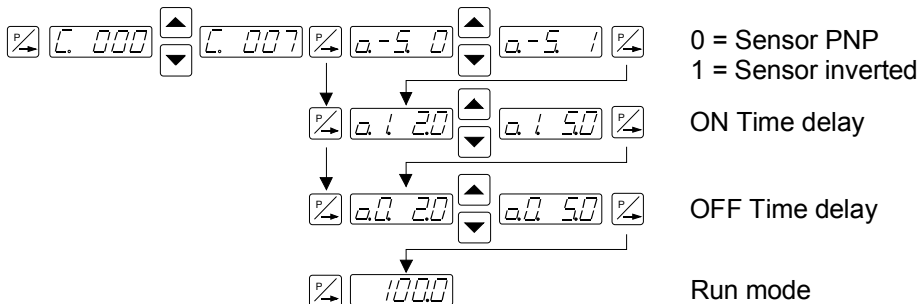

7.5 Track control channel 2 (REOVIB MTS 442 Only)

Code 006 Track control channel 2

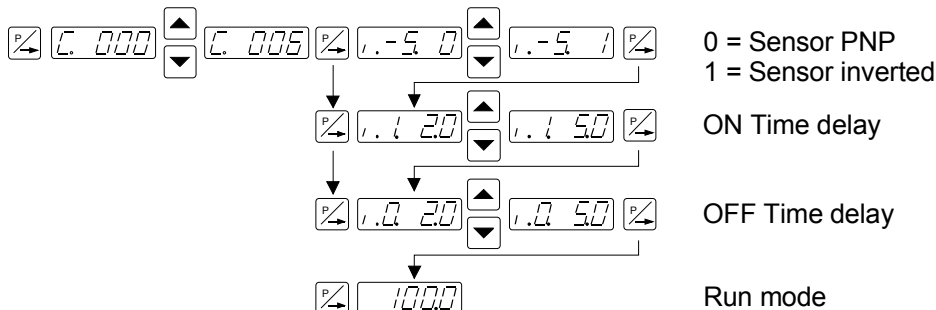

7.6 Sensor logic

Code 014 Sensor Logic

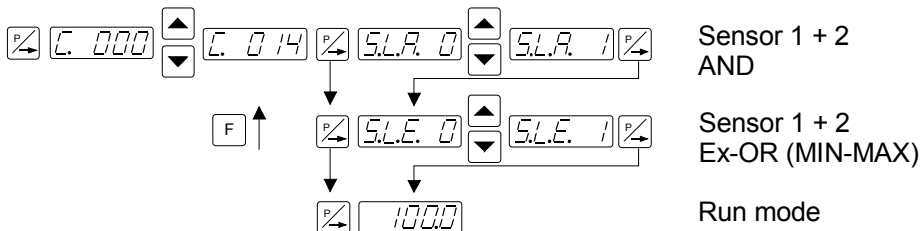

7.7 Sensor Time-out

Code 015 Sensor Time-out

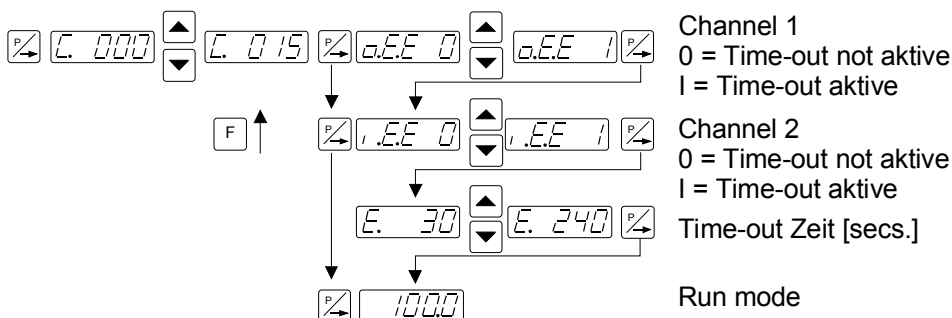

7.8 Feeder Channel 1

Code 020 Feeder Channel 1

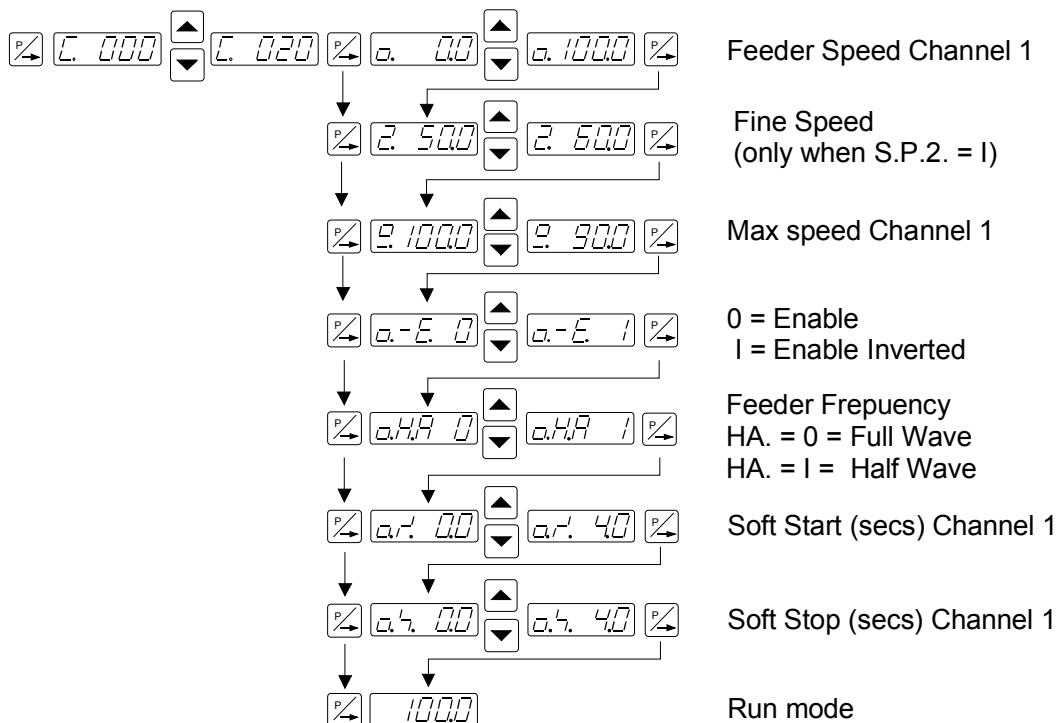

7.9 Feeder Channel 2

Code 021 Feeder Channel 2

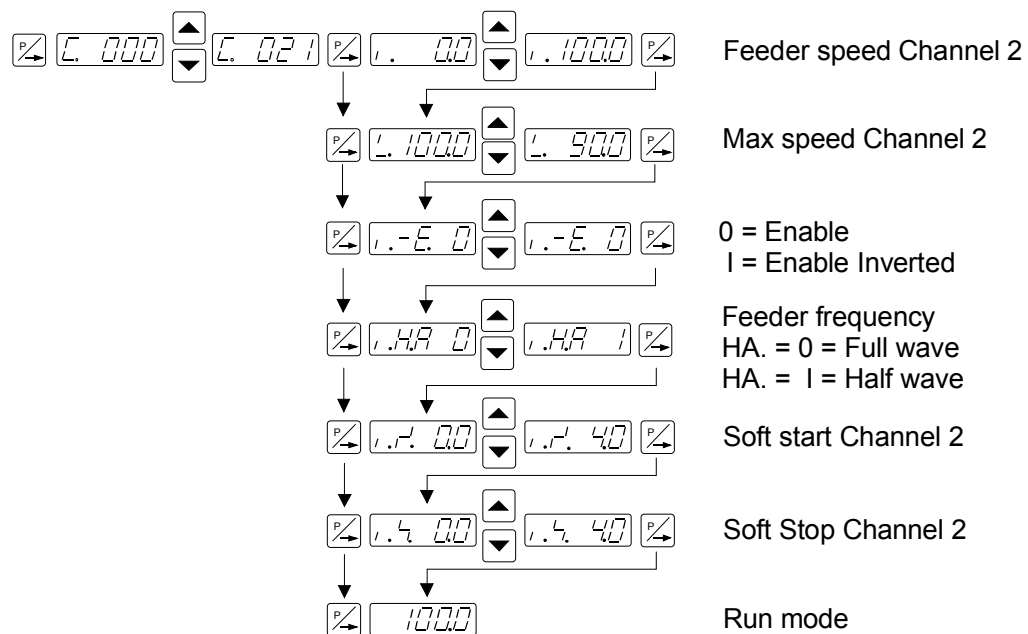

7.10 Save user settings

Store current parameter settings

Code 143 Store current parameter settings

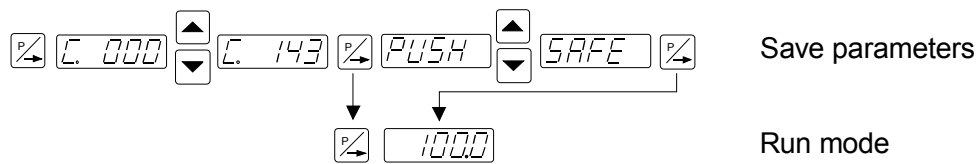

7.11 Re-instating settings

Recalling factory and user settings

Code 210 Recalling factory and user settings

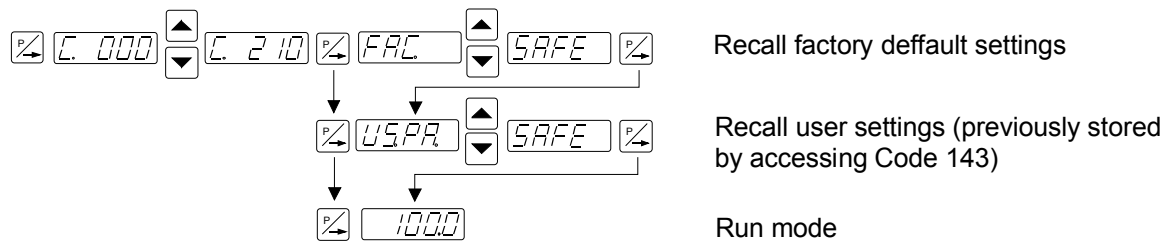

7.12 Protect unauthorised adjustment of settings

This disables all passcodes so that they cannot be accessed, except feeder speed

Code 117

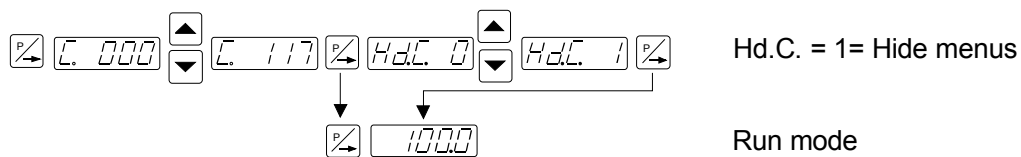

8.0 Controller Connections

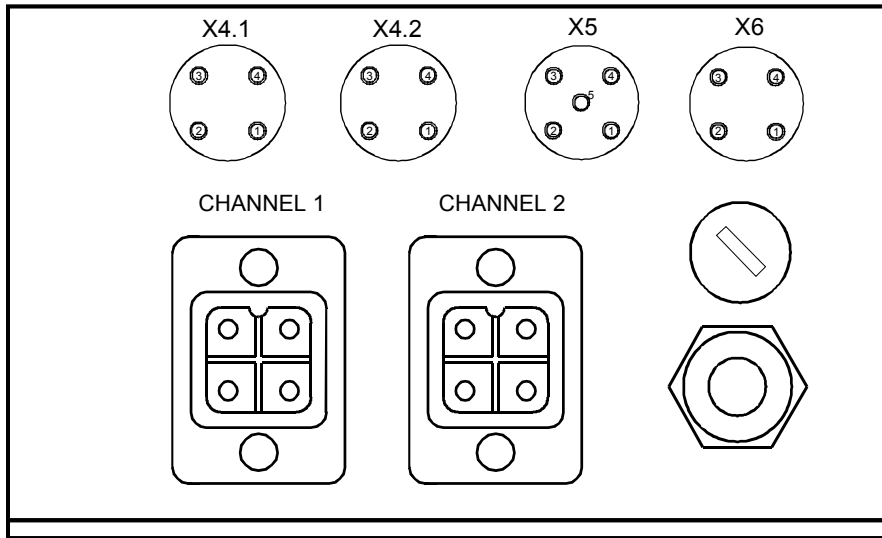

PNP Sensor Socket (X4.1 und X4.2)

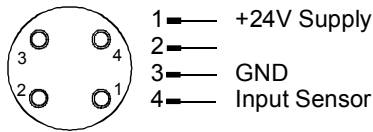

Status Socket (X5)

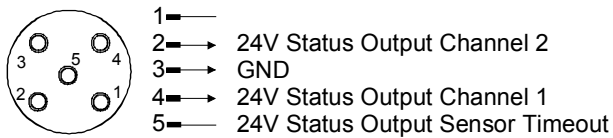

Enable Inputs (X6)

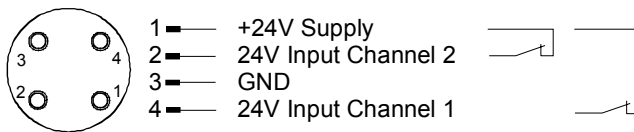

Pin 5 not connected

Output Socket Channel 1

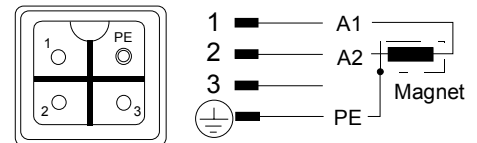

Output Socket Channel 2

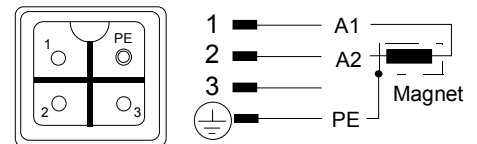

Output Cable Option

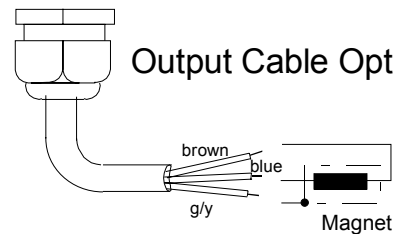

24 V Solenoid connection via internal connection terminals 21+ and 22-

8.1 Internal Connections

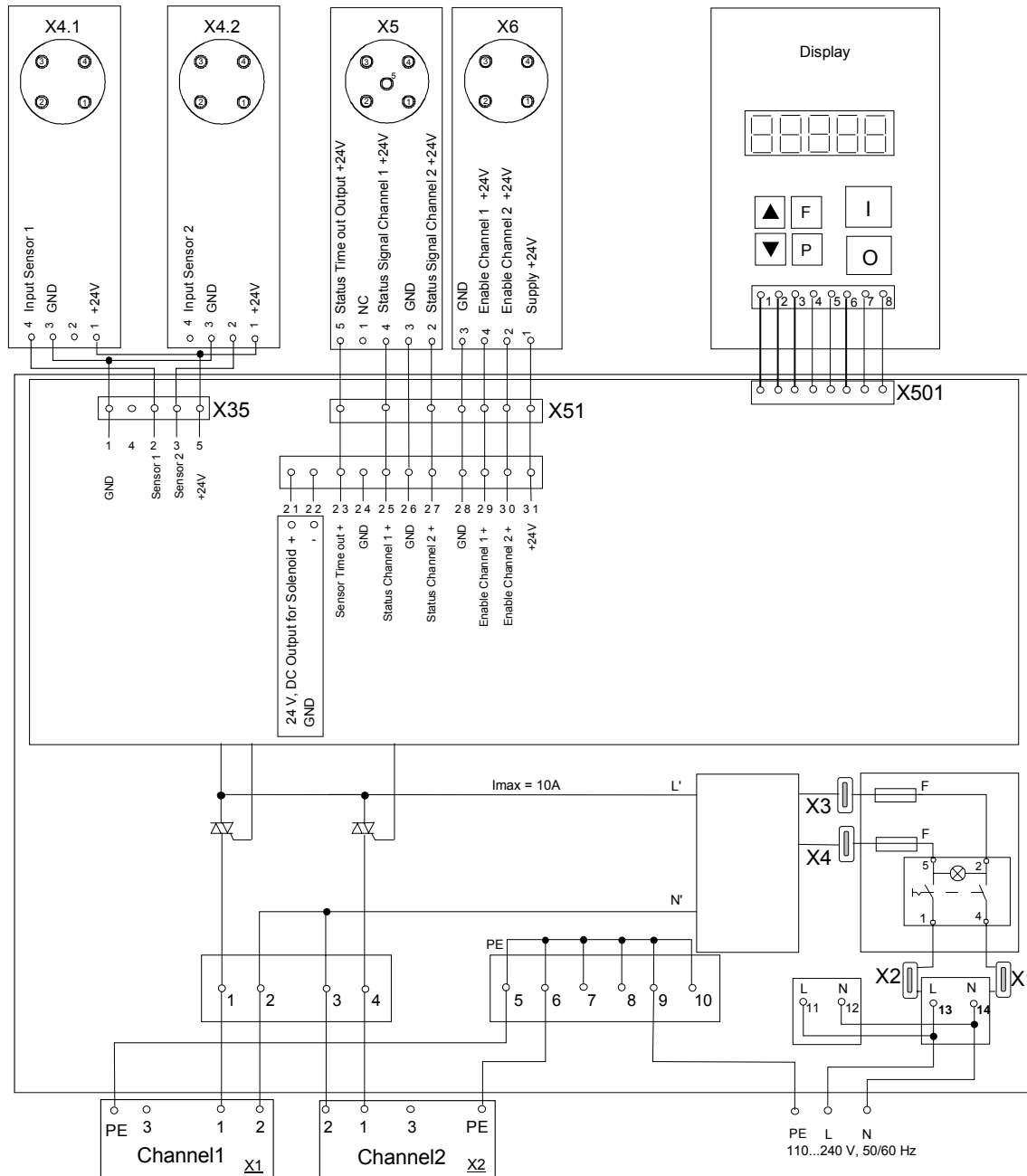

9.0 Dimensions

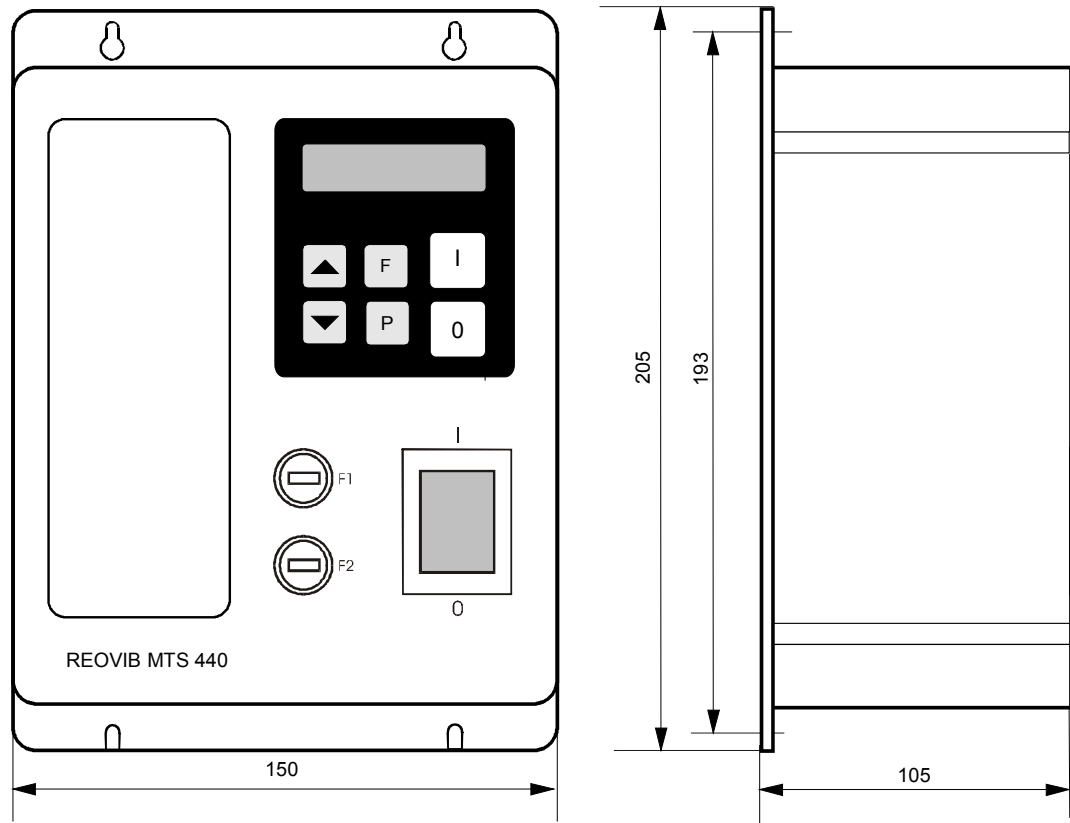

Ordering Codes

REOVIB MTS 440-05	1 Channel unit with sensor plug M12
REOVIB MTS 442-05	2 Channel unit with sensor plug M12