



Technical Description

## **REOVIB BK 032**

Amplitude Comparator

---

Your Supplier:

REO (UK) LTD  
Units 2-4 Callow Hill Road  
Craven Arms Business Park,  
Craven Arms, Shropshire, SY7 8NT  
Tel.: 01588 673411  
Fax.: 01588 672718

Publication No.: 0321.Doc

## General

The unit is used for monitoring vibratory feeders or components, which could malfunction when subjected to excessive vibration. The amplitude is measured by using an accelerometer, which is attached to the machine or piece of plant to be monitored and this is connected to an amplitude comparator. The value of the maximum and minimum amplitude can be set between 0.5 and 10 g, approximately.

Internal contacts, which changeover when the maximum and minimum amplitude values are exceeded, are available for integration into safety or signalling circuits.

The amplitude comparator operates in conjunction with a SW 07 accelerometer, or other compatible types.

## Applications

- Machine protection
- Centrifuges
- Vibratory feeders
- Monitoring air conditioning systems

## Function Description

The signal contacts, within the amplitude comparator, can be used normally open or normally closed. The amplitude comparator is connected to equipment, which has to be protected. During start up, there can be periods of instability, which have to be ignored. False tripping is eliminated by setting a time delay of between 0.5 to 15 seconds. A led "t", on the front panel of the unit indicates that the time delay is in operation. After the time delay has expired, the monitoring then becomes active and the internal relays will switch immediately after an amplitude limit is exceeded. This is indicated by "min" and "max" led's on the front panel.

An internal circuit monitors whether the accelerometer cable is in good condition and switches the unit off in the event of failure, whilst at the same time indicating a "max" exceeded condition. The unit produces the operating voltage for the accelerometer.

## Construction

The amplitude comparator is built into a DIN rail, snap-on ,module for panel mounting. Terminal covers for touch protection are fitted.

## Connection and adjustment

The unit is connected according to the diagram on the following sheet.

When the unit is switched on the "t" led will illuminate to indicate a time delay and during this time the monitoring circuit is not active. The time delay is adjusted by turning trimmer "t", on the front panel and this is set for the prevailing conditions. The time delay should allow for the equipment to reach a stable state.

The trimmers "min" and "max" can be used to set the limits as required.

<b>Technical Data</b>	
Supply Voltage	230V (+6% -15%), 50/60 Hz
Time delay	0.5 – 15 s
Amplitude range	0.5 – 10 g
Signal contacts	2 changeover relays 2 A / 250 V
Supply for sensor	+/- 15 V
Operating temperature	0 – 45 °C
Dimensions (Depth x Width x Height)	80 x 100 x 114 mm
Protection	VBG4

**Ordering Code:** REOVIB BK 032      I/D No. 03202

**Dimensions**

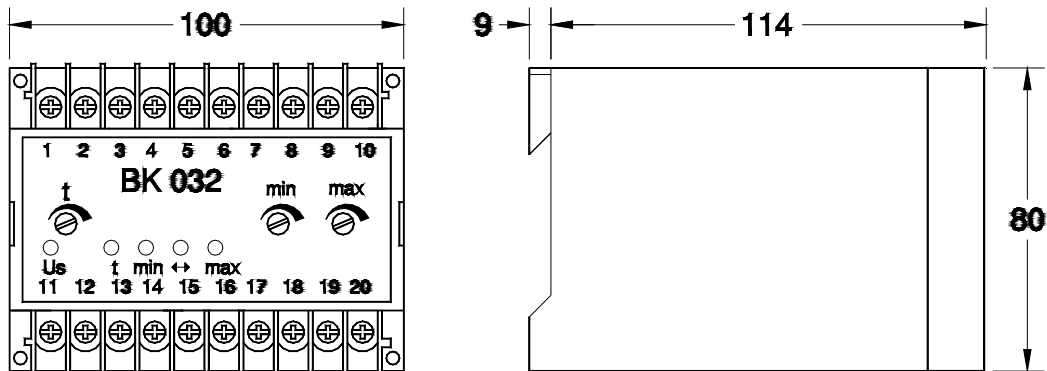

Connection Diagram

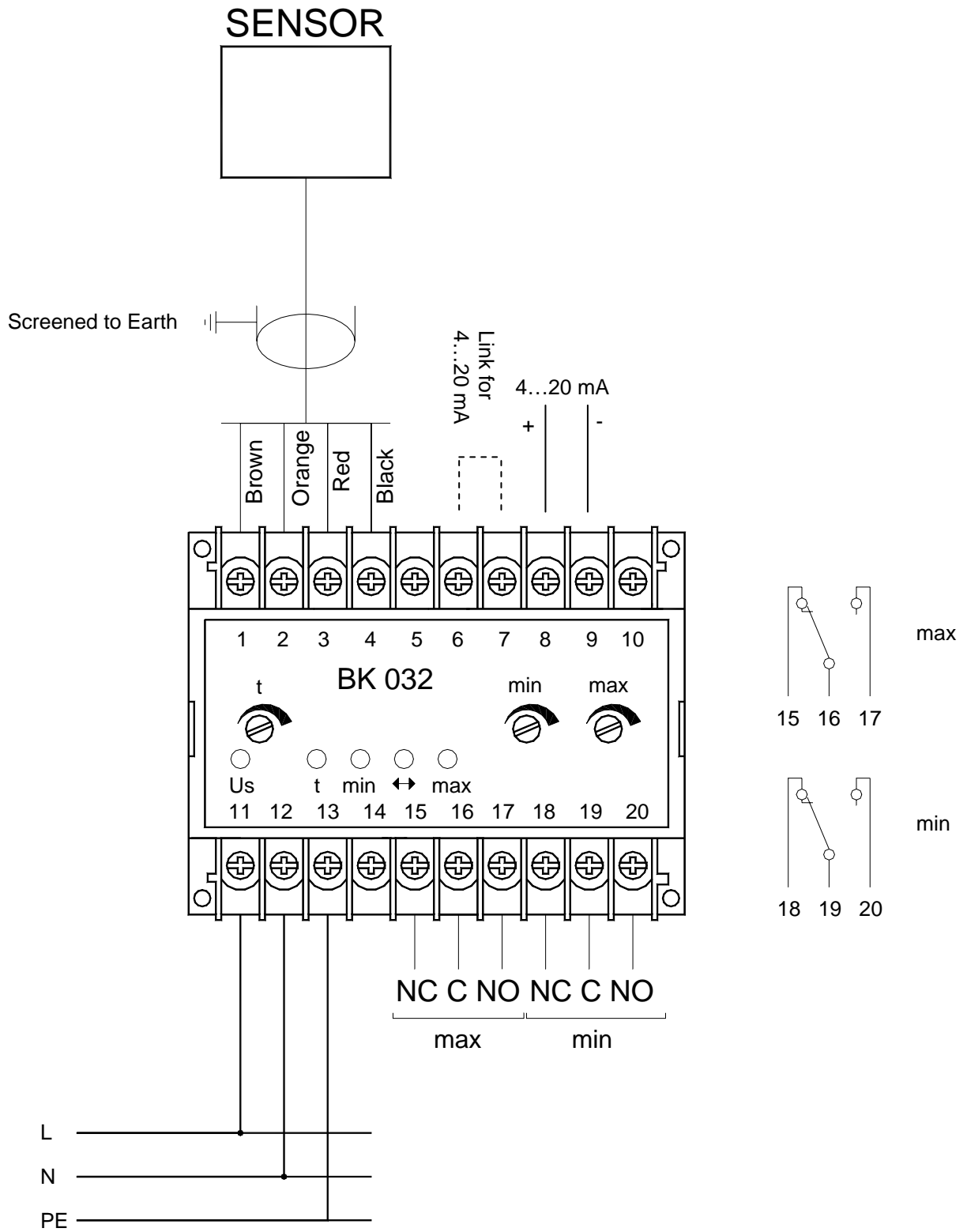

**General**

The BK032 unit is usually supplied with a accelerometer type SW011. This is used for measuring low frequency amplitude in the range 2 – 200 hz.

Inside the unit is a piezo electric amplitude sensor connected to an amplifier. The amplitude sensor generates a proportional signal according to 'g' and this is converted into a usable signal of 400mV/g by the amplifier stage.

For the unit to be effective it is imperative that it is mounted correctly.

**Installation of accelerometer**

The accelerometer should be fitted on a moving part of the feeder mechanism, ideally parallel to the feed direction (spring movement). **It must be firmly attached so that it does not generate its own vibration. A rigid mounting block or angle bracket may be used.**

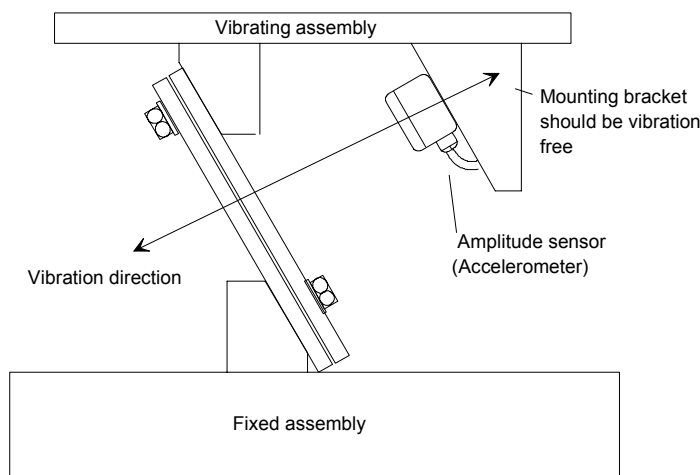

**Ideally, the installation should provide for extra clearance around moving parts.**

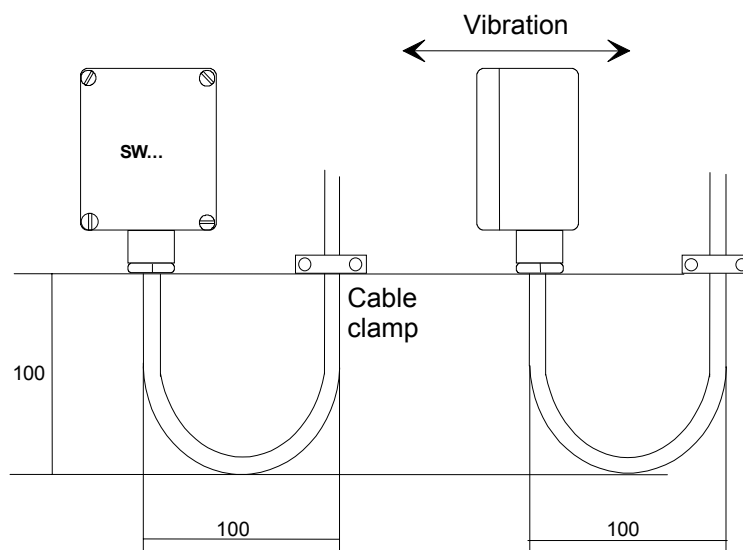

**The accelerometer cable is permanently subjected to vibration and so a loop must be provided between the sensor connection and the first clamp. The required space is not always available on small feeders, however it is important to ensure that the sensor cable is not under mechanical tension.**