

The background of the entire page is a vibrant, abstract image of lightning bolts. The bolts are rendered in bright yellow and green, with some purple and blue highlights, set against a dark, almost black background. The lightning bolts are jagged and branching, creating a sense of intense energy and movement.

Electrical fast transients and the EN 61000-4-4 test method

REO INDUCTIVE COMPONENTS AG
Bruehler Strasse 100, D-42657 Solingen, Germany
Tel: 00 49-(0) 2 12-88 04-0
Fax: 00 49-(0) 2 12-88 04-188

REO USA
3250 North Post Road, Suite 132, Indianapolis
IN46226, USA
Tel: 001 317 8991395 Fax: 001 317 8991396

Electrical fast transient burst (FTB) and compliance with the EMC Directive	2
What is FTB and how is it caused?	6
How EN 61000-4-4 simulates the EM noise from sparking contacts	8
Sources of EM noise due to sparking contacts	10
The EM phenomena associated with sparking contacts	12
The problems that can be caused by sparking contact EM noise	13
Achieving real-life reliability and low warranty costs	14
Full compliance FTB immunity testing using EN 61000-4-4:1995 + A1, A28	15
Introduction	15
The FTB test generator and its coupling devices	15
The test layout	17
The test procedure	18
Exercising the product during the test	21
Monitoring the EUT for performance degradation during FTB tests	21
Verification of the FTB generator	22
EN / IEC 61000-4-4:2004	24
On-site FTB testing	26
Preventing FTB tests from causing interference	27
Alternative transducers and test methods	29
Correlating alternative test methods with EN 61000-4-4	30
Determining an 'engineering margin'	31
References	32
Acknowledgements	34

The basic immunity test method for FTB is IEC 61000-4-4 [1], which has been adopted unchanged as the harmonised European standard EN 61000-4-4 [2]. These two standards are often called up as basic test methods by immunity standards listed under the Electromagnetic Compatibility (EMC) Directive [3].

The EN version of 61000-4-4 is technically identical to the IEC document, so this booklet is of use where either standard is required. Since many national tests outside the EU, or customer contract requirements, are based on IEC standards this booklet may also be of use in such situations.

Sparking (arcing) occurs at all types of electrical contacts whenever a current is switched. These sparks contain energy over an enormously wide band of frequencies (from below 9kHz to above 1,000GHz). The sparks give rise to transient currents, voltages and electromagnetic (EM) fields that can interfere with almost every kind of electronic device, equipment or system (called products in the rest of this booklet). So it makes good sense to test products for FTB to ensure they will work reliably, despite the electromagnetic (EM) threats from sparking electrical contacts in their intended operating environment. This is especially important in safety-related, high-reliability, mission-critical, or legal metrology electronic applications.

Some sources of electrical contact sparks



The relationship between EN 61000-4-4 and the first edition of the EMC Directive (89/336/EEC)

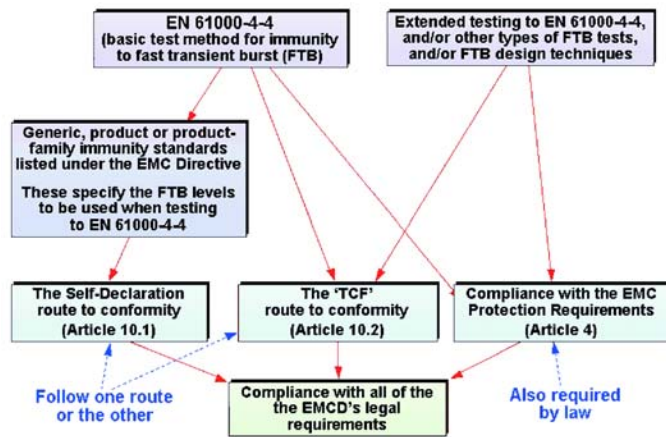

EN 61000-4-4 is a basic test standard, so when following the self-declaration to standards route to conformity (Article 10.1 in [3]), EN 61000-4-4 should *not* be listed on the EMC Declaration of Conformity. Only the relevant generic or product-family harmonised EMC standards should be listed. These will usually call-up EN or IEC 61000-4-4 as a test *method*, but it is always the generic or product-family standard that sets the minimum test *levels* which allow conformity to be claimed.

When using the Technical Construction File route to conformity with the EMC Directive (Article 10.2 in [3]) it is possible to use EN/IEC 61000-4-4 directly, in which case it *should* be listed on the product's EMC Declaration of Conformity. In such cases the product manufacturer should assess the EM environment of the product and ensure that it is designed and/or tested accordingly, so as to comply with the EMC Directive's essential "Protection Requirements" (Article 4 of [3]).

The second edition of the EMC Directive, 2004/108/EC [4], replaces 89/336/EEC on 20th July 2007. Products that are already being supplied in conformity with 89/336/EEC will be allowed to be supplied until 20th July 2009, by which date they too must comply with 2004/108/EC. Whereas 89/336/EEC requires the involvement of a Competent Body with all TCFs, 2004/108/EC effectively allows the TCF route to be used with the *optional* involvement of a Notified Body (the new term for Competent Bodies).

Under 2004/108/EC, equipment manufactured specifically for use at a named 'fixed installation' may not have to comply with any EMC requirements when it is supplied. But testing to EN 61000-4-4 at specified levels will generally be a requirement by the customer to help ensure that his fixed installation complies with the EMC Directive's Protection Requirements.

The relationship between EN 61000-4-4 and the second edition of the EMC Directive (2004/108/EEC)

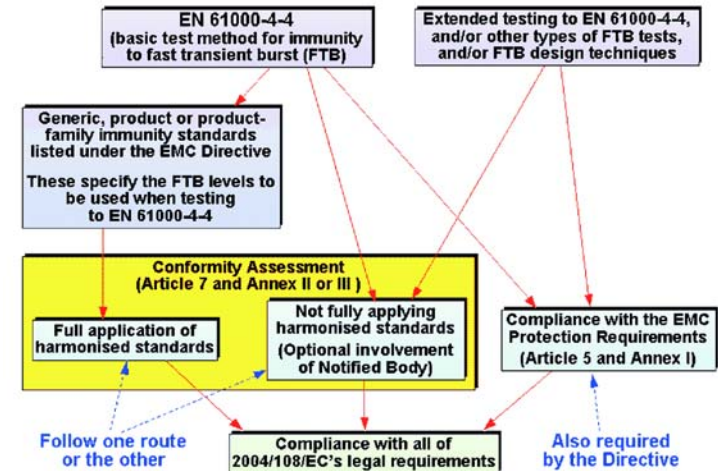

Important Safety Note: People whose health depends on the correct operation of pacemakers or other body-worn or implanted electro-medical devices should never go near any EMC immunity tests or their associated test equipment, including FTB tests or test equipment.

There may be significant financial or compliance benefits in performing FTB immunity tests that go beyond simply complying with the *minimum* requirements for Self-Declaration to the EMC Directive (Article 10.1 of 89/336/EEC). These situations are specifically *not* covered by the generic, product or product-family immunity standards listed under the EMC Directive; meaning that it is up to the manufacturer to assess the EM environment that his/her product will be used in and test it accordingly, to comply with the EMC Directive's Protection Requirements and/or to achieve improved performance quality or reliability in real life operation.

Compliance with the EMC Protection Requirements is a legal requirement that applies *in addition* to the requirement to follow one of the conformity assessment routes (Self-Declaration, Article 10.1; or TCF, Article 10.2). Products that pass tests to all relevant immunity standards listed under the EMC Directive, but nevertheless are unreliable or fail in normal use because they are not immune enough for their real-life EM environment, do not comply with the EMC Directive's Protection Requirements and are therefore illegally CE marked.

Applying EN 61000-4-4 (or similar) FTB tests which go beyond the minimum requirements of the EMC Directive's listed standards can also be a way to help make products more reliable, reduce warranty

costs, improve customer satisfaction and reduce exposure to product liability claims – for more on this refer to the section on FTB Testing and Real-Life Reliability, later.

This series of booklets is concerned with testing to the EN standards for typical domestic, commercial, light industrial and industrial environments. But other kinds of immunity tests may be required by the EMC standards for automotive, aerospace, rail, marine and military environments. Some of these industries have developed their own FTB test standards based on their own particular kinds of EM environments. For instance, automotive manufacturers employ ISO 7637 to simulate transient disturbances on 12V or 24V d.c. power supply leads.

This booklet describes how to apply EN 61000-4-4:1995 plus its Amendments 1 and 2 (both 2001) and also describes the changes that have been incorporated into the 2004 version. Where a generic or product EMC standard requires the use of the EN/IEC 61000-4-4 basic test method, it will specify either a dated reference (e.g. “EN 61000-4-4:1995”) or an undated reference (e.g. “EN 61000-4-4”). If it specifies a dated reference, then this is the version of the basic test method standard that must be used. If it specifies an undated reference then the *latest* published version of the standard should be used.

But no-one expects hordes of product manufacturers to rush to the test labs to retest all of their products on the very day a new version is published (even if it were practical). So the latest version of a standard always includes a date on which it supersedes the previous version. This is

known as the “date of withdrawal” or DOW of the previous version, and provides an overlap (usually called a transition period) during which product manufacturers can choose between the old and new versions of the standard for compliance testing. For EN 61000-4-4:2004 the DOW is 1st October 2007, so the transition period is 2½ years.

Usually it makes best commercial sense to test new products to the latest version of the standard, retesting older products to the new version when they are due for retesting anyway as a result of a design change or upgrade (as long as this happens before the DOW). In these increasingly fast-moving times, a product may only be on sale for a period of time that is less than the transition period, in which case it may never need to be tested to the new version of the standard.

A note of caution is required with respect to transition periods for standards. The EU has ruled that where Directive compliance is concerned, only dates that are published in the Official Journal of the EU (OJEU) have any relevance, and not any dates that have been put into standards by their committees. The problem that this causes for basic EMC test standards such as EN 61000-4-4 is that they are never listed in the OJEU under the EMC Directive so they (and any DOW dates) never appear in the OJEU. Since the DOW dates in the basic standards are not recognised by the EU, there can be no transition period. This consequence does not seem to have been foreseen by the EC, and causes confusion. So it is probably less risky to use the 2004 version of EN or IEC 61000-4-4, except where the regulatory requirements (for the EU or other markets) specify the exact version to be used.

What is FTB and how is it caused?

Where an electronic product has a safety-related or legal metrology function, requires high reliability, or is mission-critical – mere compliance with the EMC Directive is often insufficient for ensuring that it has been designed correctly – additional and/or tougher immunity requirements may need to be applied. Refer to the IEE's guide [5] and the article [6] for more on this, and also read the section below on 'FTB testing and real-life reliability'.

'Fast transient burst' is the name given to the conducted transient disturbance created by switching power currents using electrical contacts. Sometimes it is called 'electrical fast transient burst' (EFTB), or 'electrical fast transient' (EFT) instead, but in this booklet it will be referred to as FTB.

For the time that the contacts are sparking (arcing) as they open, EM noise is created over an enormously wide bandwidth – from very low audio frequencies to over 100GHz.

All conductors have inductance, and some loads have a great deal of inductance (transformers, motors, etc.). Inductance stores energy, according to the formula $Energy = \frac{1}{2}LI^2$ (in Joules), where I is the current in Amps and L the inductance in Henries. When the current in a conductor or inductive load is switched off, their inductance prevents the current from stopping instantaneously. The voltage that develops across the contacts of an electrical switching device is related to the rate of change of current by $V = -L \frac{dI}{dt}$, and the rate of rise of the flyback voltage across the switching contacts also depends upon the stray capacitances associated with the circuit.

V is called the inductive flyback voltage, and we can see that if we try to break the current flow instantaneously (as an electrical contact tries to do when it opens), the contact voltage can become very large. At some point, the voltage becomes enough to break down the air gap between the contacts, causing a spark discharge.

The first spark occurs when the contact has only just started to open. As the contacts move further apart the arc shuts off and the resulting high rate of change of current

A simplified example of the sparking at an electrical contact

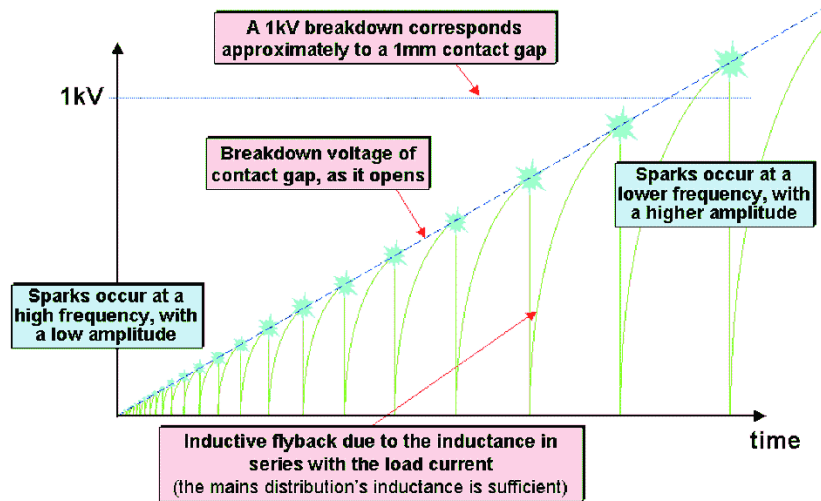

causes another flyback, and another spark. This continues until the stored energy in the inductance of the conductor or the load is all dissipated, or until the air gap is so large that the available flyback voltage cannot break it down – in which case it dissipates by means of a 'glow discharge'. The rate of sparking is very high when the air gap is very small – maybe a few MHz – decreasing in frequency as the air gap size increases until it may be just a few tens of kHz. For a lot more detail on the mechanisms involved in sparking at contacts, see Chapter 7 of [7].

Mains cables attenuate very high frequency signals, so the frequency range of the 'spark noise' that is actually conducted into a product is considerably less than 100GHz. The longer the cable, the lower the upper limit of the spark noise spectrum.

Sparking can also occur at the closing of a contact, due to contact bounce. The sparks can occur after the first contact has allowed some current to flow, which is then interrupted by the following bounce. But the currents involved are usually not as high as when the full load current is switched off, so the sparking and FTB noise amplitude is usually not as high.

When switching 50 or 60Hz mains currents, the size of the spark (and hence the level of the resulting EM noise emissions) depends upon the phase angle of the current at the moment of switching. If contacts are opened quickly when the phase angle of the current is zero, there will be no spark noise and no FTB.

How EN 61000-4-4 simulates the EM noise from sparking contacts

The standard FTB test waveform

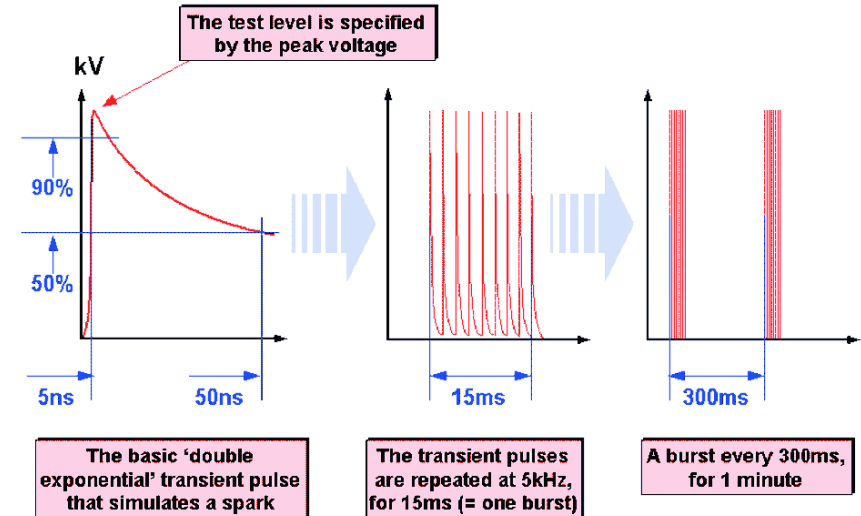

To try to create a repeatable simulation EN 61000-4-4 uses a defined transient voltage pulse waveform to simulate each spark, and a 'spark rate' of 5kHz rate for a duration of 15ms, repeated every 300ms for a minute.

Some early FTB instruments used actual spark gaps, but modern ones use power switching transistors instead because the performance of a spark gap is not very predictable. The use of power transistors also enables 100kHz pulse rates to be achieved, as required by the 2004 edition of EN 6100-4-4 (see later).

The rise and fall times of the transient pulse waveform were chosen to generate a frequency spectrum (by Fourier analysis) that corresponds well enough with the typical spectrum of a single spark that has been low-pass filtered by the radio-frequency (RF) attenuation of a length of mains cable. The rise-time of each

transient pulse is 5ns, which implies that the energy in the output spectrum of an EN 61000-4-4 FTB generator falls off rapidly above 64MHz. This is considered acceptable because ordinary mains cables have increasingly higher attenuation as frequencies exceed 50MHz – but it assumes that there is a considerable length of mains cable between the source of the spark and the product concerned (not always the case in real-life, see later).

The range of spark rates that occur during the opening of a real contact gap can vary from MHz to kHz during each contact opening. This sweep of frequencies might include frequency at which the product concerned is particularly susceptible, due to the frequency of operation of a circuit or software process. Early (pre-1995) drafts of IEC 1000-4-4 (as it was called then) proposed testing with both 5kHz and 100kHz pulse repetition rates, and at least one manufacturer produced FTB

generators that achieved this. But the standard that was published in 1995 only required testing at 5kHz (and 2.5kHz at the ± 4 kV test level). As a result, the 5kHz pulse rate might not reveal the real-life susceptibility of the product. However, the 2004 version of the standard (see later) uses a 100kHz pulse rate that it says is "more realistic".

The 15ms duration of the transient pulses repeated at 5kHz was chosen because when switching a.c. mains, most of the switches (and relays, thermostat contacts, etc.) in domestic and commercial equipment spark for less than 15ms in order to help comply with regulatory EM emission limits. But in real life not all sparking contacts spark for such a short time (see later).

The FTB waveform defined by EN 61000-4-4:1995 is calibrated with the FTB test generator discharging into a purely resistive 50 Ω load. But in real life the FTB generator will be discharged into conductors that have impedance that is often very different from a 50 Ω resistance. Since FTB generators are only specified by their waveform into a 50 Ω load, and not by their circuits or constructional details, different generators from different manufacturers will give unpredictably different waveforms when testing loads which are not 50 Ω resistors. This problem has been recognised and Amendment 2 in 2001 specified the generator waveshape into both 50 Ω and 1000 Ω resistive loads. This amendment came fully into force in July 2004, so for full compliance testing all EN 61000-4-4 generators should now comply with Amendment 2:2001.

Example of different real-life pulse waveforms from two different FTB generators

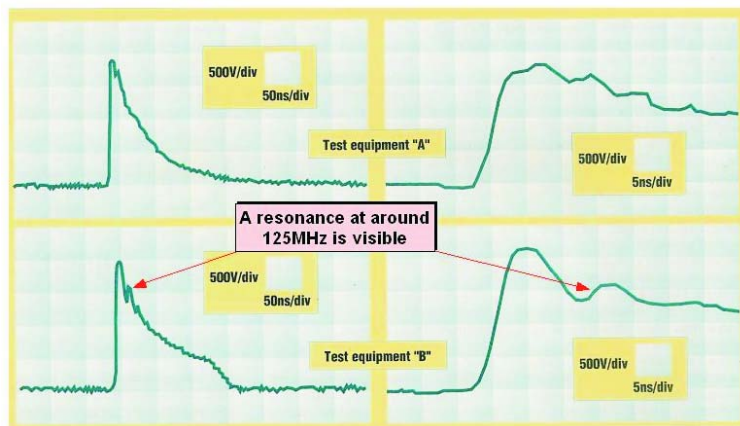

Taken from [7]

The top and bottom plots show the waveforms injected into a product by different FTB generators. The product passed when tested with generator A, but failed with B.

Using FTB generators that complied with the original 1995 edition of EN 61000-4-4, resonances have been found on the trailing edge of the pulse waveforms' output by some FTB generators into some loads [8]. Even though generator waveshapes must now meet their specification into the above two values of resistance, there is still the possibility that the reactive loads they have to drive in real life could result in different pulse waveshapes in practice.

An additional contributor to waveshape differences is that the way the pulse waveform is specified in the standard may not be precise enough, allowing different generator models to claim compliance even though their waveshapes into the specified resistors differ.

A final issue is that the applied test stimulus is specified as the peak of the generator's output voltage into an open circuit – not the calibrated voltage. The peak open circuit voltage is not the voltage that appears at the cable terminals of the product tested, which depends on the ratio between the FTB generator's source impedance and the load impedance presented by the cable being tested.

EN 61000-4-4 simulates the sparking at the switching contacts of a.c. mains switches, relays, thermostats, etc., but anything that sparks creates very wideband EM noise that can cause interference with electronic devices, circuits and the software that runs on them (see later).

Most types of commutator motors generate sparks every time their electrical brushes leave a commutator segment. The rotors of most types of these motors have a significant inductance, so large flyback voltages can be generated by commutator switching, resulting in a lot of sparking. It seems to be a rule that the cheaper the motor, the worse its commutator sparking noise is. The author has seen several examples of 1.5V d.c. commutator motors in children's toys that emitted much more EM noise than industrial d.c. motors rated at 10kW and 400V. Portable electric drills are a common cause of interference due to their sparking commutators.

The rate of the sparks depends on the number of commutator segments and the rotational speed of the rotor. Most of us have at some time heard 'whining' and 'ticking' interference when listening to a car radio (especially AM channels). Whining is caused by the commutator noise from generators (on older cars), windscreen wiper or other d.c. motors, and its pitch is related to the speed of the motor's rotor and usually lies in the audible frequency range. The regular ticking noises on the car radio are from the spark ignition, and the pulse rate depends on the engine's speed and number of cylinders.

The opening of a fuse can create a great deal of 'sparking contact' noise as the gap in the fusible element melts. Fuse opening is usually associated with larger than usual

currents, so the sparking can be severe unless HRC (high rupturing capacity, usually filled with sand) types are used.

Spark ignition also finds common use in igniting domestic and commercial gas and oil burners, such as are used for water heating and for cooking, although the pulse rate is usually between 1 and 4Hz.

Poor electrical contacts can also spark, sometimes making an audible buzzing or fizzing noise. Unlike an opening contact, the rate of the sparks (pulses) depends upon the power frequency, load current and climatic conditions. They can continue to emit a more-or-less constant noise level for days, weeks, even months.

The starters used with traditional magnetic ballasts for fluorescent lamps create sparks when they operate, and this creates FTB-type noise. When switching on the lights in an office or other large space, the tens (sometimes hundreds) of individually sparking starters causes FTB type emissions to occur continuously for several seconds. (And there is often at least one dead tube whose starter keeps trying forever to ignite, until the starter itself fails.)

When a product is connected to a sparking contact (e.g. the on/off switch of another item of equipment) by only a short length of power cable, the higher frequencies present in the spark suffer less attenuation by the cable, and the 5ns rise-time of the EN 61000-4-4 test might not have a short enough rise-time to simulate all of the spark's noise frequencies. In such situations, verifying a design by testing with an EN/IEC 61000-4-4 FTB generator that has been modified to have a pulse rise-

time of less than 1ns, will better simulate the real-life transient noise and should help to achieve higher real-life reliability.

It sometimes occurs that a product's own on/off switch or other electrical contacts cause interference with itself. It is not unusual for the operation of switches, relays or commutator motors in a product to crash its microprocessors or else cause its software to do odd things. In such situations there can be a great deal of EM noise created by the sparks at frequencies above 600MHz, implying that to simulate it with an EN 61000-4-4 type of FTB generator would require modification to generate rise-times of 0.5ns or less, and connection to the tested equipment by a very short length of cable (<100mm) to reduce RF attenuation.

Because EN 61000-4-4 is considered to be a conducted immunity test, it is often assumed that the only EM phenomena created by FTB events are pulsed currents and voltages. But the pulsed currents and voltages in the tested cable emit powerful radiated electric and magnetic fields.

The contact gap itself acts like an 'accidental transmitting antenna', but is generally so small that it is not very efficient at less than 20GHz. But the cables connected to the contact (or in close proximity) also behave like an accidental antenna for the RF noises produced by the spark. The typical lengths of mains power cables (and the distribution networks they are connected to) make them very effective at emitting fields down to a few tens of kHz. So a sparking contact injects pulsed RF currents and voltages in conductors, and radiates pulsed RF electric and magnetic fields.

The fields associated with FTB events are often discovered when people are trying to improve the immunity of their product to FTB injected into a given cable, by using filtering (the automatic – but incorrect – assumption is that conducted disturbances can be fixed solely by filtering). But if there is an aperture in the product's shielding near to the cable concerned, the field leakage through this gap can bypass the filter and cause upsets in their product's circuits and software.

It is rapidly fluctuating a.c. or d.c. currents that cause the flyback voltages that cause FTB events, and these fluctuating currents create fluctuating magnetic fields that have a lower frequency spectrum than the magnetic fields emitted by the 'spark'

currents. In the case of a fuse opening, the currents involved are usually more than 10 times the circuit's normal load current, and the pulsating magnetic fields can be correspondingly larger.

The problems that can be caused by sparking contact EM noise

13

Radio and TV receivers can suffer interference from the EM fields produced by sparking contacts and their cables. AM radio is very susceptible, FM less so. It is quite normal to hear a 'click' or a 'splat' when listening to an AM radio programme, whenever a light switch is operated, or a thermostat opens. Wireless data communications usually use modulation techniques that make them less susceptible to interference, and some use communications protocols that provide a degree of error correction. The occasional click or splat or lost packet of data is usually acceptable, but when the source of the FTB-type noise is the commutator of an electric motor, the radio or TV interference or the reduction in data rate might be unacceptably high. This sort of problem is commonly experienced when a portable electric drill is plugged into the same region of the mains distribution network.

Audio systems that are not sufficiently well protected from conducted or radiated RF can suffer audible clicks or splats due to RF noise entering via their mains power or signal cables. In large installations, such as football stadiums, there can be numerous sparking contacts from the thermostats controlling the heaters in the food concessions stands and many other types of electrical contacts that are frequently switching, and the resulting high rate of audible clicks and splats can be very annoying.

Many instrumentation transducers and their amplifiers employ the audio frequency range, and if they are not adequately protected from FTB noise they can suffer momentary errors, or continuous errors when the source is a commutator motor.

The levels of overvoltages used in FTB testing can permanently damage all

semiconductors (e.g. integrated circuits, ICs) and many other electronic devices. The internal silicon features (transistors, conductors, etc) are so small, and have such a low thermal inertia, that even very small pulses of energy can cause actual physical damage. Also, the spacings between conductors (metallisation) in a typical integrated circuit are so small that overvoltage damage can occur at levels of only a few tens of volts.

However, FTB testing usually does not cause actual device damage because it only uses direct injection into a.c. and d.c. power cables, and ICs are never connected directly to the mains power supply. ICs connected to d.c. power cables almost always benefit from large amounts of power decoupling capacitance, which absorbs most of the energy in the FTB event and helps prevent actual damage.

FTB test injection into signal, data and control cables is done via a 100pF capacitor (the capacitive clamp, see later), so the amount of energy that can be coupled into the product is very much less than can be coupled into a.c. or d.c. power cables. So once again actual device damage is not a normal result of FTB testing.

Although actual device damage is unusual as a result of sparking contacts (and FTB testing), the signals used in circuits can easily suffer interference from the various EM phenomena associated with such events. D.c. and low-frequency analogue signals experience FTB as a momentary 'glitch' that might not be very important (depending on the circuit and its application). FTB interference with high-speed and high-frequency analogue circuits are more likely to cause malfunctions, for instance interference with

the gate drive signals in switch-mode power converters can cause cross-conduction leading to explosive disassembly of the power switching devices (i.e. they can blow up, and large power converters can explode with as much energy and shrapnel as a grenade).

Digital signals can often easily suffer interference from FTB, because even where the signals themselves might have a very low rate the digital devices they are connected to can usually respond very quickly indeed, registering FTB events as false signals. The reduction in d.c. power supply voltage for modern digital ICs means that their logic thresholds are reduced in proportion, leading to increased susceptibility to noise.

If the spark rate coincides with an operational frequency in an analogue or digital system, or with the rate of operation of a software process, the susceptibility of a product can be worsened. Pulse counting circuits (e.g. in timers and counters) can count at the 5kHz rate of the interfering noise instead of at the 1Hz (or whatever) rate they are supposed to, leading to erroneous timing or counting.

Some examples of real-life interference due to the EM noises caused by sparking contacts are included in [9].

14

A big problem with warranty claims and field service is the 'no-fault-found' customer return. Many manufacturers spend considerable amounts of money to try to keep their customers happy, despite not knowing what the cause of the problem is. Many no-fault-found problems appear to be caused by inadequate immunity performance, but EMC and FTB events can be hard to repeat (and few service personnel or customers are EMC/FTB experts or have any EMC/FTB testing gear).

The financial rewards of producing products with adequate immunity can be very great indeed, as one UK manufacturer discovered when they spent £100,000 on redesigning their products to comply with the new issues of the EMC Directive's immunity standards around mid-2001, and found to their complete surprise that their product's new designs saved them £2.7 million in warranty costs *per year*.

As you can see from the above sections, EN 61000-4-4 only covers a small range of possible 'sparking contact noise' events, and various different models of FTB generators might give different results when testing the same equipment [8], even if the generators are all compliant with the same version of EN 61000-4-4.

There are military and automotive industry EMC immunity standards that test FTB type EM events in a different way to EN 61000-4-4 (using different test waveforms). Using such standards, or extending and toughening tests under EN 61000-4-4, and/or using test generators that better simulate the anticipated real-life FTB events (see above), can help produce more reliable products.

But complying with any immunity test standards (even the ones used for flight control computers on civil airliners) does not necessarily guarantee sufficient real-world reliability. This can be a problem for safety-related equipment and systems, or for equipment and systems that require very high reliability (such as speed cameras). This issue is too large to be discussed here, for more on this refer to [10] and the IEE's training course on EMC for Functional safety, high reliability and legal metrology [11].

If it is suspected that FTB is a cause of failures in the field, a survey with a portable spectrum analyser and suitable antenna and close-field probes can discover what FTB events are occurring and where they are being generated. It is also possible to use less costly/more portable site-survey instrumentation for this purpose – for example a portable AM radio with built-in ferrite rod antenna could be used, tuned between broadcast channels to maximise its sensitivity. It might even be possible to use the direction of the ferrite rod to help locate the source of the noise.

Introduction

This basic FTB test standard aims to simulate the EM effects of sparking electrical contacts. This booklet is not a complete recital of everything that is in EN 61000-4-4, only a general guide. Anyone performing tests to this standard must have a copy of its relevant version (including any amendments), and follow it exactly.

FTB generators compliant to the latest version of EN/IEC 61000-4-4 are easy to buy or hire, and relatively straightforward to use, and no special test facilities are required (but see the section on preventing interference).

The EN 61000-4-4 standard basically consists of three things: a description of the burst generator and its cable coupling devices, a description of the test layout and instructions for the test procedure.

The FTB test generator and its coupling devices

The FTB test stimulus consists of a single unidirectional pulse repeated at a 5kHz rate in bursts lasting 15 milliseconds each, with about three bursts per second for a minute. A.c. and d.c. power cables have the transient bursts injected directly into them via specified coupling-decoupling networks (CDNs). These CDNs are contained within proprietary FTB test instruments, but can also be made by following the instructions and schematics in EN 61000-4-4.

Signal and data cables have the transient bursts injected via a specified design of capacitive clamp. These clamps are usually purchased but can easily be made using common materials by following the detailed construction drawing in figure 5 of

FTB generator and coupling/decoupling network

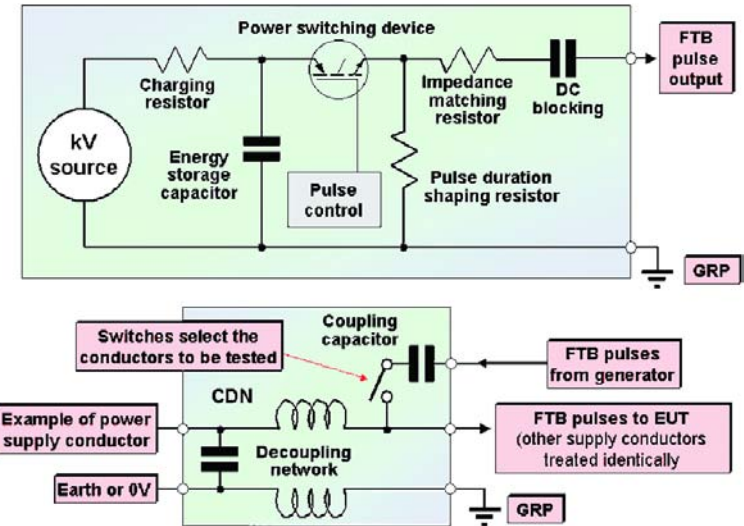

A typical FTB test set-up

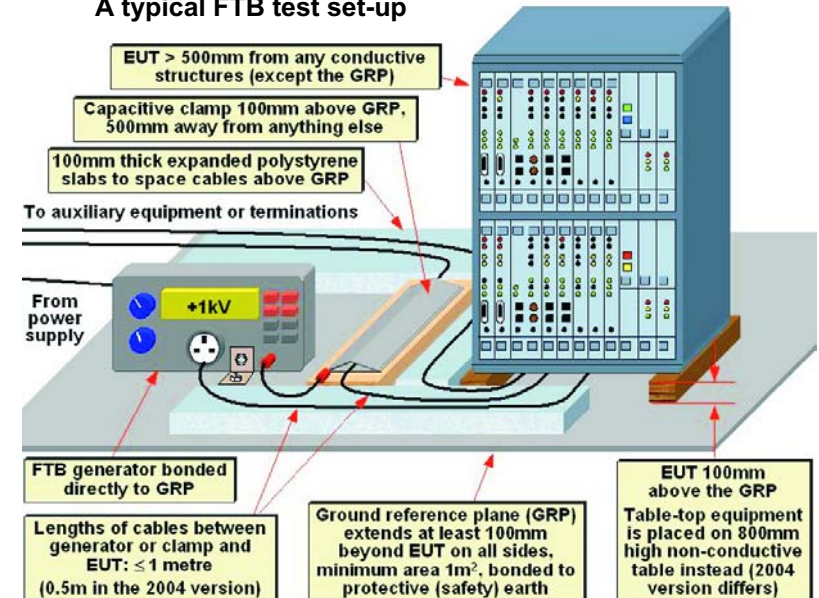

Construction details for a capacitive clamp

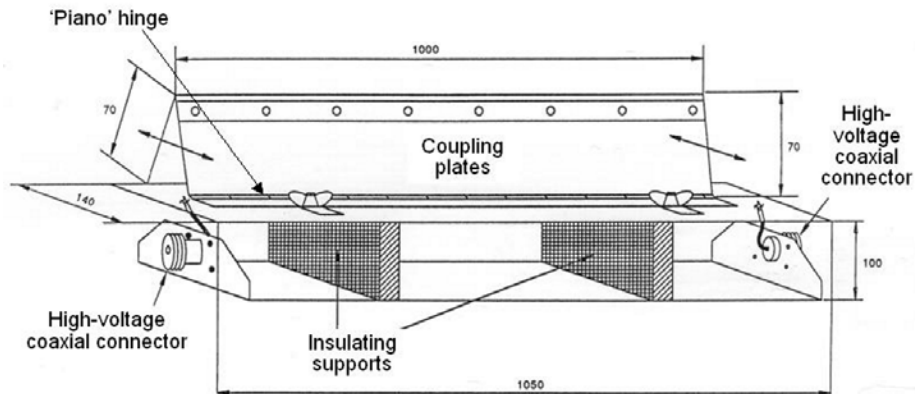

Dimensions in millimetres

Warning: The distance of the coupling section to all other conductive constructions except to the cable under test and ground plane shall be more than 0,5 m.

When testing signal and data cables be aware that the capacitive clamp has no directionality, so any auxiliary equipment being used in the test set-up is also subject to the FTB on its cables. Suppression techniques may be needed for the auxiliary equipment (such as passing the cables through a bulkhead-mounted filter in a screened-room wall, and/or clip-on ferrite cable suppressers) to allow the response of the 'equipment under test' (EUT) to be measured correctly. Suppressers based on chokes and ferrites are preferred, as capacitive filters may prevent the signal cable from experiencing the FTB stimulus in the way that it would in a real application.

The test layout

The FTB is a wideband phenomenon with spectral components up to hundreds of MHz and therefore, as with other RF tests, layout is important for repeatability. The coupling of the burst is strongly dependent

surroundings. Layout issues in EN 61000-4-4 include:

- A ground reference plane (GRP) of at least 1m square that extends beyond the EUT by at least 100mm all around.
- The FTB generator is bonded to the GRP by a short metal strap (not a length of wire) and this means that the generator will normally sit on the floor, not on an adjacent table. (This makes remote software control of the generator more desirable, as a remedy for backache.)

Alternatively the GRP could be at table-top height, as long as other distances are maintained.

The EUT is spaced from the GRP plane by 100mm or, for table-top equipment, 800mm. (An 800mm high wooden table is used here, as it is in many other EMC tests.)

- A clear distance around the EUT. The minimum distance from the EUT to all other conducting structures – and this includes the test generator and capacitive coupling clamp, a condition that is sometimes forgotten – must be 500mm. The capacitive coupling clamp itself must also have a clear distance around it of at least 500mm.
- If the EUT will be separately earthed in the real installation, then it must be connected to the GRP in a representative manner. No additional earth connections are made.
- The distance between the EUT and the coupling network or clamp must be 1m or less. Long cables should be coiled with a 400mm diameter and positioned 100mm above the GRP.

It is wise to maintain the cable separation of at least 100mm from the GRP under all conditions for all cables, not just the one being tested. 100mm thick blocks of expanded polystyrene are often used to provide this spacing.

- The capacitive clamp itself must be 100mm above and directly bonded to the GRP. This introduces a conflict for EUTs that have cable entries greater than 1m above the floor, since either the cable must be further than 1m from the clamp or the clamp has to be raised above the floor.

In this situation, the method described in Figure 8 of the 2004 edition of EN/IEC 61000-4-4 should be used.

The test procedure

The procedures for applying the bursts are generally straightforward – the standard requires at least one minute for each coupling mode that is tested, which for a repetition period of 300ms means at least 200 bursts. The product or generic standard being invoked will determine which cables are tested.

In contrast to other transient tests (such as ESD or Surge) the standard only requires the application of the specified test level. For the capacitive clamp application, this means that only two minutes' testing is needed per cable: one minute at each polarity. However, most test labs increase the test level in steps to check for lower- and higher-level susceptibilities. The steps are usually 25%, 50%, 75% and then 100% of the specified test level (e.g. $\pm 250V$, $\pm 500V$, $\pm 1kV$, $\pm 2kV$).

Mains supply FTB tests can apply the bursts to any single supply conductor, and/or to any combination of the supply conductors: L, N, E, L+N, L+E, N+E, and L+N+E in the case of an EUT powered by a single-phase earthed supply. All of these are tested with a stimulus that is referred to the FTB test set-up's GRP.

EN 61000-4-4 does not specify the supply conductors or combinations to be tested. It merely shows an example of coupling via CDN and does not mandate any particular combination. All FTB generators are equipped with switches that allow the supply conductors to be tested singly or in any combination. A few early product and generic standards refer to testing with EFT bursts in "common mode", which could be interpreted as requiring application to L+N+E only. The issue from the point of

Testing mains supplies - one line at a time

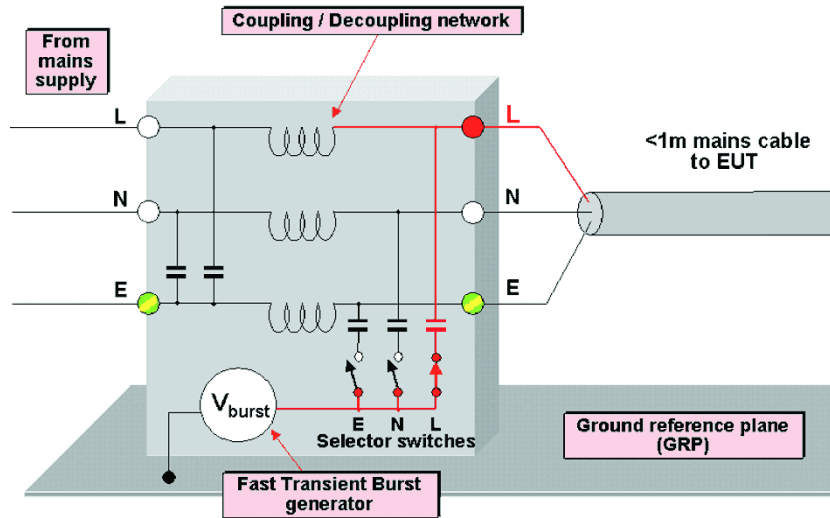

view of product compliance could be significant, since it is often found that FTB immunity varies considerably depending on which supply conductors, or which combinations of supply conductors, are tested.

Given this lack of guidance in the standard, the best advice is to test each individual supply conductor, and also to test all of the possible combinations of supply conductors. Combining this with testing at stepped levels up to the specified level – with both positive and negative polarities – increases the test time considerably.

Where three-phase products are tested for FTB, the number of possible tests on single supply conductors and combinations of them increases even more. Generators with built-in three-phase CDNs are not as common as those intended solely for testing single-phase products.

Testing mains supplies - pairs of lines (L+N shown)

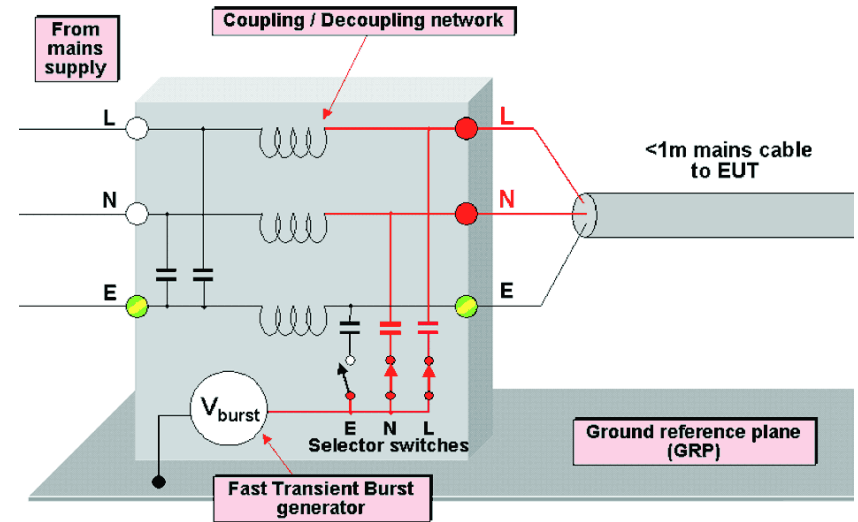

Testing mains supplies - all lines together

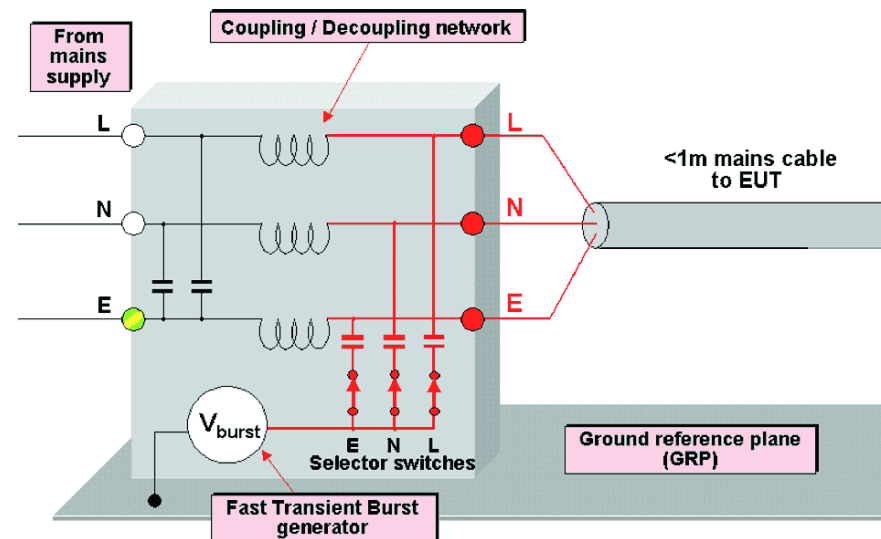

Exercising the product during the test

As is usual with EMC test standards, EN 61000-4-4 requires that equipment be set-up and operated as close as possible to its normal operation in real life.

During the execution of software, the susceptibility of a product to interference is usually much worse at some instants than it is for the rest of the time. These instants are usually not known in advance, making it a problem for a transient test, such as FTB, to be applied at just the right instant to achieve the worst-case response. So, for each FTB tested cable, the bursts are repeated for at least one minute – to try to ensure that at least one burst occurs at a time when the software state of the product is most susceptible.

EN 61000-4-4, like all other immunity tests in the EN 61000-4 series, requires all of the normal modes of operation of the EUT to be tested. Where this would take a long time, special exercising software can be run on the product, to save testing time, but it must comprehensively exercise the product.

For some products, electrical, mechanical, hydraulic or pneumatic loads; high-power three-phase electrical supplies or supplies of hydraulic or pneumatic power (e.g. compressed air) may be required, to be able to test the product as it will be used in real life. When testing lift (elevator) drive systems, for instance, it is normal to use a large flywheel that has a moment of inertia similar to that of a loaded lift car.

REO can create custom loads to meet any requirements



Monitoring the EUT for performance degradation during FTB tests

The functional performance degradation allowed during and after FTB immunity tests may be specified by product-family standards, but if applying the generic standards EN 61000-6-1 (which has replaced EN 50082-1) or EN 61000-6-2 (which has replaced EN 50082-2) all that is necessary is that the performance is no worse than the specification in the 'manufacturer's data sheet' for the product – which should represent what its users would find acceptable given the marketing claims for the product.

Thought should be given to how the functional performance of the product is to be tested with appropriate levels of accuracy and repeatability, well before the product's planned testing date, so that any special testing arrangements can be made. For example, some electrical or electronic test instruments can themselves be upset by nearby FTB events, or by the transient currents that flow down the interconnecting cables.

Where an accredited test laboratory provides the functional instrumentation, they will no doubt have already discovered how to make it immune enough. But where functional testing employs instruments provided by the product manufacturer (e.g. signal or distortion analysers, display screens, computers, etc.) this can lead to lengthy spells of time spent trying to decide whether it is the EUT or the test equipment that is failing, all the while burning money at premium test laboratory rates.

Also, test laboratories book their work weeks (or even months) in advance, allocating customers testing timeslots that *should* be long enough to perform the required tests. Where customer-supplied functional test equipment is upset by FTB tests, and no quick fixes seem to work, it is possible to run out of time trying to fix the susceptibility of the test equipment, then having to wait a few weeks (maybe months) until another timeslot can be booked to test the product.

Verification of the FTB generator

EN 61000-4-4 describes the calibration/verification required for an FTB generator, but does not describe the construction of the 50 and 1000 loads used for calibration. These loads should follow good RF engineering practice and maintain their impedance (pure resistance) up to at least 400MHz.

Many test labs will simply rely on the annual calibration of their FTB generator at an independent calibration laboratory, but equipment can fail or go out of calibration at any time (due to normal wear and tear or random failure). It is good practice to verify an FTB generator's performance every time it is to be used, otherwise, some

unknown proportion of the last year's FTB tests could be in error. When doing FTB testing on-site (see later) the transport of the equipment increases its physical stresses and makes failure more likely, so it is always recommended to verify an FTB generator's performance before using it on-site. Note that the 2004 edition of EN 61000-4-4 requires the FTB generator's output to be "checked" before testing.

Ideally – when the FTB generator to be used has just returned from its most recent calibration and has not yet been used for any testing – obtain your own 'laboratory reference measurement' for the FTB generator's direct output by injecting fast transient bursts at $\pm 1\text{kV}$ into the FTB verification fixture.

The FTB verification fixture can be constructed in many different ways. The suggestion in this booklet is to inject the output from the FTB generator's direct output (normally used to connect to the capacitive clamp) into a wideband current injection transducer (injection clamp) in its own calibration fixture. The spectrum of the injected current is then measured on a spectrum analyser. (Injection clamp calibration fixtures can be bought from the manufacturers of the injection clamps.)

The FTB generator output should pass through a 50 RF power attenuator having at least 26dB of attenuation and capable of handling 1kV transient inputs – *before* it is input into the current injection clamp. This is to protect the sensitive input of the spectrum analyser.

Example verification test fixture for an FTB generator

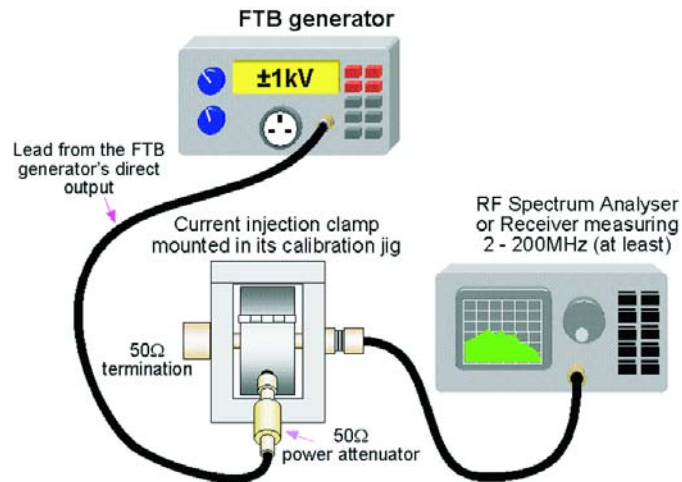

The same injection clamp, calibration jig and spectrum analyser set-up can form part of a verification system for EN 61000-4-6 and EN 61000-4-5 tests.

The energy in the FTB generator's transients is low, but the voltage is high so the 50 Ω RF power attenuator will probably need to be rated for 20 Watts power so that it will handle the peak voltages. When selecting an attenuator, always check (using an oscilloscope) that the peak voltage at the output of the attenuator is exactly what you would expect given its attenuation specification and the output voltage of the FTB generator.

The RF power attenuator combined with the loss in a typical current injection clamp should limit the peak pulse voltage at the spectrum analyser's RF input to about 1V, and so prevent the possibility of damage to the spectrum analyser's RF mixer stage. However, prior to the first test, it is recommended that data is obtained

on the conversion factor (amps to volts) of the BCI clamp and the maximum input voltage of the spectrum analyser and then calculations are done based on the FTB generator's ability to source 1kV peak into a 50 Ω load, to check whether more than 26dB of RF attenuation should be used. (Note that a spectrum analyser's internal attenuator cannot be used to increase its maximum input voltage rating.)

To obtain the laboratory reference measurement, the FTB generator is set to output its transient bursts at its normal repetition rate and the spectrum analyser is set to 'peak hold' free-run mode for the frequency range 2MHz to 200MHz (at least) with either a 100kHz or 120kHz resolution bandwidth. The test is allowed to run until no significant further changes are observed in the measured spectrum (this should take much less than one minute). The resulting spectrum display is saved as the laboratory reference measurement to be used for future FTB generator verifications.

Laboratory reference measurements could be made for both polarities of a number of output voltages, but it is usually sufficient to make just two: one for an FTB setting of +1kV, and one for a setting of -1kV. Each measurement should record the full set-up details for the verification fixture and the spectrum analyser.

The verification fixture's actual lead and actual RF power attenuator should always be used for FTB verifications – so it is best if the lead, attenuator and laboratory reference measurement results are always kept with the FTB generator and not used for any other purposes.

To verify the FTB generator at a future date, the same procedure as described above is gone through, using exactly the same FTB generator, lead, RF attenuator, injection clamp and clamp calibration jig, spectrum analyser settings and test set-up.

The two spectrum displays obtained (for +1 kV and -1 kV FTB generator settings respectively) are then compared with the laboratory reference measurements, and the differences noted. If the differences are within ± 3 dB, the FTB generator is judged to be in full working order.

It is a good idea to include details of the FTB verification and a judgement on whether the FTB generator is functioning correctly in the EMC Test Report, or in some other QA controlled document, so that years later when all the personnel have changed it can still be discovered whether a particular FTB test had been done with a fully working generator.

The EN version of IEC 61000-4-4:2004 was published in December 2004, with a DOW for the 1995 version of 1st October 2007. Product or generic standards that use undated references to basic test standards require the 2004 version of EN/IEC 61000-4-4 to be applied immediately, whereas those that use dated references allow the 1995 version to be used until 31st September 2007 (although this is not recommended, when using the self-declaration route to declaring conformity, as it would require retesting the following day to the 2004 version).

The changes that have been made in the 2004 edition include the following...

- The repetition rate for all voltage levels (other than "X") is now defined as either 5kHz or 100kHz. Product standard committees should determine which frequencies are relevant for specific products or product types. The burst length varies in inverse proportion to the pulse rate, so that the total energy delivered to the EUT in each burst is the same. At 5kHz burst rate the burst duration is 15ms, but at 100kHz the burst duration is 0.75ms.

But real sparking contacts do not exhibit this relationship between pulse rate and burst duration. Although it may be more realistic to test with 100kHz pulse rate the 0.75ms burst duration may not deliver as much average power as a real sparking contact. Also, the long periods of time that remain between these very short bursts mean that critical periods in the operation of a products software are less likely to be tested.

- The specifications for the coupling clamps have been changed.
- The test set-up requires all equipment, whether floor standing, table-top or wall or ceiling mounted, to be positioned 100mm above the GRP that the FTB generator is electrically bonded to, on insulating supports. (In the 1995 edition table-top equipment was mounted 800mm above the GRP.) All cables associated with the EUT should also be placed 100mm above the GRP on insulating supports.
- Cables not subjected to electrical fast transients are to be routed as far away as possible from the cable being tested.
- The length of the cable between an FTB coupling device and the EUT has been changed from “1m or less” in the 1995 edition to “0.5m +/- 0.05m”.
- Where the 0.5m distance between the coupling device and the EUT cannot be achieved, for example on large products where cables enter high up, the coupling clamp and FTB generator shall be suspended on an additional, elevated GRP, so as to achieve the 0.5m cable length. The elevated GRP should be electrically bonded to the main (floor) GRP. Figure 8 in the 2004 edition shows this new arrangement.
- The climatic conditions state: “Unless otherwise specified by the committee responsible for the generic or product standard, the climatic conditions in the laboratory shall be within any limits specified for the operation of the EUT and the test equipment by their

respective manufacturers. Tests shall not be performed if the relative humidity is so high as to cause condensation on the EUT or test equipment.”

- When using repetitive bursts it is possible for the bursts to be synchronised with the EUT's operational cycle, and so not test the EUT properly. The 2004 edition permits a pause in the bursts to help prevent synchronisation, as long as the total length of time that the bursts have been occurring for is no less than 1 minute. However, product standard committees are permitted to choose other test durations.
- Each test report must now state whether the FTB generator meets the tolerance requirements of IEC 61000-4-4, taking into account the calibration uncertainty.

So apart from a few differences in the test set-up (cable lengths, spacings from GRP, etc.) most of the differences in the 2004 version are associated with the design of the generator and the pulse rate and burst duration at which testing is done.

On-site FTB testing to EN 61000-4-4 is easy to do, because of the relatively simple test set-ups required, the portability of the test gear, and the fact that suitable methods are described by the standard. Chapter 10 of [12] also describes on-site FTB testing, which requires the use of a ground reference plane at least 1 metre square.

In locations where the 1 metre length of the regular capacitive clamp is too large to fit, it can be replaced with wound tape or conductive foil 1 metre long that creates the equivalent common-mode capacitance (100pF). Shielded 'Zippertubing' 1 metre long on an insulating support can be a simple alternative capacitive clamp and is easy to apply in the field.

It is even acceptable to connect the output of the FTB generator directly to the cable screen or signal terminals via discrete 100pF capacitors (high-voltage ceramic type). Because this is not a distributed coupling method it may give different results from the standard capacitive clamp, so should be used with caution, and only where the 1 metre capacitive clamp cannot be used for some good reason.

On-site testing is best restricted to proving that an installation is not susceptible, rather than declaring EMC conformity for a product using the 'standards' route. However, an EMC Competent Body could well accept on-site testing when following the Technical Construction File (TCF) route to EMC compliance, especially for custom equipment intended for a specific site.

The variability of non-standard test set-ups may be able to be offset to some degree by overtesting, say by testing at up to double the level required by the relevant immunity standard. Of course, the non-standard test method might already be making it a more aggressive test; so increasing the test level might result in a very aggressive test indeed and lead to over-engineering of the product. This is part of the price you pay when deviating from a standard test method.

On-site FTB testing can interfere with other equipment or systems. See the next section on dealing with this.

Important Safety Note: Don't forget that interference, especially with aircraft or other vehicular systems, some machinery or process control systems, and implanted electronic devices such as pacemakers, can have lethal consequences and appropriate precautions **must** be taken to make sure that nobody's safety is compromised by FTB testing.

It is also a good idea to take precautions where there is a possibility of significant financial loss being caused by the interference from on-site testing.

When FTB tests are performed, the very wideband frequencies generated can be emitted from cables and metalwork, especially at their resonant frequencies. These emissions can interfere with nearby equipment, so it may be necessary to conduct the tests in a location that is far enough away from other equipment not to cause a nuisance.

Some EMC test laboratories perform their FTB tests inside shielded rooms or shielded tents (no need for any RF absorber if the enclosure is room-sized) to prevent emissions from causing interference problems. Shielded tents have the advantage that they are easily movable (compared with a metal screened room) and can be packed away when not in use.

Some EMC laboratories and manufacturers use metal shipping containers – easily modified with gasketed doors, mesh-shielded ventilation and filtered mains supplies – as shielded rooms for FTB and other transient immunity tests, to help avoid interference with nearby equipment. The containers are usually painted nice bright colours inside and make a very low-cost type of shielded room, strong and stable enough to be stacked several high if floor area is tight.

But FTB immunity tests are often done outside shielded chambers, or on-site, for example for diagnostics or when collecting test evidence to support a Technical Construction File for a large system or an installation.

Of course, the product being tested must operate properly in the first place, and if testing on a site that suffers from high levels of EM 'noise' it may be necessary to use filtering and shielding techniques to be able to distinguish between the effects of the ambient noise and the effects of the test. Similarly, where the FTB testing might cause interference to other equipment, it may be necessary to use filtering and shielding techniques to prevent this from happening.

A selection of typical REO Filters for a.c. supplies



If either of the above situations arises, there are a number of issues that will need to be taken into account to suppress the interfering frequencies effectively. Suitable filtering and shielding techniques are described in [13]. It may be possible to shield the system being tested with a shielded tent, and filter each of the cables entering or leaving the tent at least with a large ferrite clamp or number of small clip-on ferrite clamps, placed at the point where the cable penetrates the tent. Ferrishield, Inc. make some very large ferrites for this purpose: their CS28B2000 has its peak impedance at 300MHz, CS25B2000 at 700MHz, and CS20B2000 at 2.45GHz. Don't forget that a shielded tent usually requires a shielded base that is joined all around its edges – it may not be enough to simply drape a five-sided shielding tent over the equipment being tested.

An example of a low-cost shielded tent



If working on exposed live equipment an isolating transformer may be able to be used to help reduce electric shock hazards. It is best to choose special 'high isolation' types of transformers, which have a very low value of primary-to-secondary capacitance, plus choose transformers that are rated for the likely surge levels (at least 6kV, using the IEC 61000-4-5 test method) to help ensure safety.

High-isolation transformers may also be used to help prevent FTB tests from injecting noise into the mains distribution network of the rest of a site.

REO isolating transformers



Important Safety Note: Always take all safety precautions when working with hazardous voltages, such as 230V or 400V (3-phase) electricity. If you are not sure about all of these precautions – obtain and follow the guidance of an electrical health and safety at work expert. When constructing equipment that employs hazardous voltages, always fully apply the latest versions of all relevant parts of EN/IEC 61010, at least.

Testing using alternative methods from those in EN 61000-4-4 cannot give any real confidence that 'full-compliance' tests for FTB immunity would be passed. But such non-compliant tests may be valuable for improving the reliability or quality of a product, especially if they simulate the FTB voltages and currents that could be present in its real-life EM environments.

Many equipment rental companies have stocks of EN 61000-4-4 calibrated test gear needed to do FTB immunity tests properly, and will rent them out for daily, weekly, or monthly periods. So the easiest way to perform these tests with reasonable accuracy and lowest cost is often to hire the equipment and do the tests yourself. Note that saving money on test labs by doing testing yourself requires competence (appropriate skills and experience, and attention to detail and documentation).

The test set-ups for FTB immunity are not difficult to achieve in a typical manufacturing company, as they don't necessarily have to be performed in special test chambers – but see the earlier section preventing FTB tests from causing interference.

However, a number of alternative FTB generators and test methods can be used where EN 61000-4-4 compliance is not required. The use of home-made FTB generators, for example the 'chattering relay' (which has been used in some old test standards), can be very helpful for testing during design and development, fault finding and QA, but is not described here. See [14] for more on alternative FTB generators.

Second-hand and hired FTB testers are also available, but it helps to check that they comply with the version of EN/IEC 61000-4-4 called-up by the product or

generic immunity standard.

For all but compliance and 'pre-compliance' tests, using an uncalibrated test (for which the quantitative measurement is not traceable to the national physical standards) is not very important. But it *is* very important for *any* tests to be *repeatable* – so consistency is always required in the test equipment and test methodology.

During design, development or QA testing, always try to reproduce the final assembly of the circuit being tested (shielding, earth bonding, proximity to metal objects or structures, etc.), as the stray inductances and capacitances in the final build state can have an important effect on the FTB behaviour of the product. And always carefully record all the details of the test set-up in the test documentation (photographs can be very useful).

When self-declaring compliance to the EMC directive using the Standards Route to conformity (Article 10.1) – even if chattering relay or similar tests have been done to simulate the operating environment and help achieve reliability – it is still best to test to (and pass) EN 61000-4-4 to help avoid the possibility of legal challenges in the future.

But when following the Technical Construction File (TCF) route it may be possible to persuade your Competent Body that the tests you have done represent the environment that the product is going into and there is no need to apply EN 61000-4-4 as well. This argument would probably only be acceptable for a custom-designed (bespoke) industrial product intended for use at a specified site, and not for portable products or equipment that could be used in a number of locations or sites.

When an alternative FTB test method is used for design, development, or troubleshooting after a test failure, repeatability of the test is very important (even though the correlation with EN 61000-4-4 may not be). All such tests will need to follow a procedure that has been carefully worked out to help ensure that adequate repeatability is achieved.

When alternative methods are used as part of a QA programme, or to check variants, upgrades, or small modifications, a 'golden product' is recommended to act as a sort of 'calibration' for the test equipment and test method. Golden product techniques allow low-cost EMC test gear and faster test methods to be used with much more confidence. Refer to section 1.9 of [15] for a detailed description of how to use the golden product correlation method.

If alternative methods are used to gain sufficient confidence for declaring compliance to the EMC Directive, the golden product method is very strongly recommended. Without a golden product or some similar basis for correlating a proper compliance test (using EN 61000-4-4) with the alternative method actually used, the alternative method might only provide any confidence at all if gross levels of overtesting are applied, and this can result in very expensive products.

For EMC tests where the waveshape of the stimulus is important, as it is for FTB testing, simply increasing the test level may not always compensate for the incorrect test method. In the case of FTB, the rise-time, fall-time, energy and waveshape of the test stimulus are all at least as important as the peak test voltage.

The closer a test method is to using the proper test transducers and methodology in EN 61000-4-4, the more likely it is that a good correlation will be achieved. So testing with a chattering relay (for example) might only be able to correlate with EN 61000-4-4 for a particular build state of a specific product.

The need for engineering margins

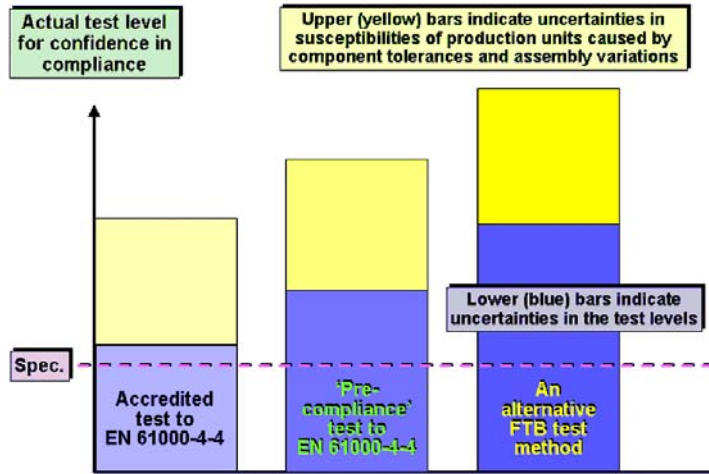

Even having EN 61000-4-4 fully applied by the same accredited EMC test laboratory cannot guarantee that a given EUT will be exposed to *exactly* the same FTB stimuli each time it is tested. But if EMC enforcement agents test a product, they are unlikely to use the same test laboratory or model of FTB generator as the manufacturer. So, an FTB immunity engineering margin is recommended, because...

- There can be differences between the actual FTB test levels when a generator is discharged into the specified 50 and 1000 loads, compared with the generator's settings or displayed levels;
- There can be significant variations in the actual FTB waveforms produced by different models of generators when testing the same product;
- There can be variations in the test methods, even when applied by the same staff at the same test laboratory, leading to different results;
- Serially-manufactured products have variable immunity performance due to component and assembly tolerances (IC die-shrinks or mask-shrinks are a major concern in this area);
- Analogue and digital circuits have non-linear sensitivity to RF noise, so small variations in the rise-time, fall-time, peak voltage level or waveshape of the FTB test can have large effects on product performance.

So, when testing an example product to EN 61000-4-4 in a fully compliant manner, performing an additional test with at least a 6dB higher level (e.g. $\pm 4\text{kV}$ at 5kHz rate, instead of $\pm 2\text{kV}$) is suggested, for all cables tested, with the product still meeting its required functional specifications.

Where a manufacturer is using an FTB generator or test method that is not identical to EN 61000-4-4, a larger engineering margin is recommended (but how much larger is very hard to determine other than by direct comparison of the effects of the different test methods on the same EUT).

EN 61000-4-4 requires testing to not exceed the specified maximum test level, to avoid damage to the product – but if the customer requests testing to higher levels the test laboratory should be happy to oblige.

The increments in the FTB test levels specified by EN 61000-4-4 can be added to by additional steps, if specified by the customer. So instead of going straight from $\pm 2\text{kV}$ to $\pm 4\text{kV}$, additional tests at $\pm 3\text{kV}$ might be added, for extra confidence.

Saving costs by using alternative FTB test methods can lead either to over-engineering or to non-compliance with the EMC Directive. The additional cost to make the product pass the alternative test method with the necessary engineering margins should be weighed against the cost of doing the testing properly.

[1] IEC 61000-4-4:1995 plus amendments A1:2001 and A2:2001, "Electromagnetic Compatibility (EMC) – Part 4: Testing and measurement techniques – Section 2: Electrostatic discharge immunity test. Basic EMC Publication".

NOTE: the 2004 edition is now available.

[2] EN 61000-4-4:1995 plus amendments A1:2001 and A2:2001, "Electromagnetic Compatibility (EMC) Part 4: Testing and measurement techniques – Section 2: Electrostatic discharge immunity test. Basic EMC Publication".

NOTE: the 2004 edition should be available when this booklet is published.

[3] European Union Directive 89/336/EEC (as amended) on Electromagnetic Compatibility. The Directive's official EU homepage includes a downloadable version of the current EMC Directive and its successor; a table of all the EN standards listed under the Directive; a guidance document on how to apply the Directive; lists of appointed EMC Competent Bodies; etc., all at: http://europa.eu.int/comm/enterprise/electr_equipment/emc/index.htm.

NOTE: the 2nd Edition EMC Directive 2004/108/EC has now been published in the Official Journal of the European Union, and will become optional from mid-2007 and mandatory from mid-2009. This booklet is based on complying with 89/336/EEC.

[4] European Union Directive 2004/108/EC on Electromagnetic Compatibility (2nd Edition), from: http://europa.eu.int/eur-lex/lex/LexUriServ/site/en/oj/2004/l_390/l_39020041231en00240037.pdf

[5] The IEE's 2000 guide: "EMC & Functional Safety", can be downloaded as a 'Core' document plus nine 'Industry Annexes' from <http://www.iee.org/Policy/Areas/Emc/index.cfm>. It is recommended that everyone downloads the Core document and at least reads its first few pages. Complying with this IEE guide could reduce exposure to liability claims.

[6] "EMC-Related Functional Safety An Update", Keith Armstrong, EMC & Compliance Journal, Issue No. 44, January 2003, pp 24-30, on-line at: http://www.compliance-club.com/keith_armstrong.asp.

[7] "Noise Reduction Techniques in Electronic Systems, 2nd Edition", Henry W Ott, Wiley-Interscience 1988, ISBN 0-471-85068-3.

[8] "Conducted Immunity Doubt with Ambiguous Standard", Trevor Boxer and Tim Williams, Approval, Nov/Dec 1996, pp 29-30.

[9] Examples of interference due to fast transient bursts can be found in the "Banana Skins compendium", via <http://www.compliance-club.com> or at: <http://www.compliance-club.com/archive1/Bananaskins.htm>.

[10] "Why EMC testing is Inadequate for Functional Safety", Keith Armstrong, IEEE 2004 International EMC Symposium, Santa Clara, August 9-13 2004, ISBN 0-7803-8443-1, pp 145-149. Also Conformity magazine, March 2005 pp 15-23, downloadable via <http://www.conformity.com>

[11] "The IEE's Training Course on EMC for Functional Safety (also for high-reliability and legal metrology)", visit

<http://www.iee.org> for their event calendar to check the date of the next course. If no courses are listed contact the IEE's Functional Safety Professional Network (via the same IEE homepage) and ask.

[12] "EMC for Systems and Installations", Tim Williams and Keith Armstrong, Newnes 2000, ISBN 0-7506-4167-3, RS Components Part No. 377-6463.

[13] "EMC for Systems and Installations – Part 4 – Filtering and shielding", Keith Armstrong, EMC & Compliance Journal, August 2000, pages 17-26, download it from: http://www.compliance-club.com/keith_armstrong.asp.

[14] "EMC Testing Part 3 – Fast Transient Burst, Surge, Electrostatic Discharge", Tim Williams and Keith Armstrong, EMC & Compliance Journal June 2001, pp 19-29. On-line at http://www.compliance-club.com/keith_armstrong.asp.

[15] "EMC Testing Part 1 – Radiated Emissions", Tim Williams and Keith Armstrong, EMC & Compliance Journal February 2001, pp 27-39. On-line at http://www.compliance-club.com/keith_armstrong.asp.

EN and IEC standards may be purchased from the British Standards Institution (BSI) at: orders@bsi-global.com. To enquire about a product or service call BSI Customer Services on +44 (0)20 8996 9001 or e-mail them at cservices@bsi-global.com. IEC standards may be purchased with a credit card from the on-line bookstore at www.iec.ch, and many of them can be delivered by email within the hour.



Keith Armstrong from Cherry Clough Consultants

This guide is one of a series. You can request all published and future guides by sending an email to main@reo.co.uk or from our website at www.reo.co.uk

Keith Armstrong graduated in electrical engineering with a B.Sc (Hons.) from Imperial College London in 1972, majoring in analogue circuit design and electromagnetic field theory, with a Upper Second Class Honours (Cum Laude). Much of his life since then has involved controlling real-life interference problems in high-technology products, systems, and installations, for a variety of companies and organisations in a range of industries.

Keith has been a Chartered Electrical Engineer (UK) since 1978, a Group 1 European Engineer since 1988, and has written and presented a great many papers on EMC. He is a past chairman of the IEE's Professional Group (E2) on Electromagnetic Compatibility, is a member of the IEEE's EMC Society, and chairs the IEE's Working Group on 'EMC and Functional Safety'.

Contact: Keith Armstrong by email at keith.armstrong@cherryclough.com or visit the Cherry Clough website www.cherryclough.com

Acknowledgement

Some of this material was previously published in 2001 - 2002 in the EMC Compliance Journal's, series "EMC Testing": <http://www.compliance-club.com> or http://www.compliance-club.com/keith_armstrong.asp. Many thanks are due to Tim Williams of Elmac Services, <http://www.elmac.co.uk>, timw@elmac.co.uk, my co-author for that series. Thanks are also due to Phil Carter of aCEmark Europe Ltd, <http://www.acemark.com>, phil-carter@acemark.com, for assistance with details of the 2004 edition of EN61000-4-4.