



## Common-mode disturbances in the frequency range 0Hz to 150kHz

REO INDUCTIVE COMPONENTS AG  
Bruehler Strasse 100, D-42657 Solingen, Germany  
Tel: 00 49-(0) 2 12-88 04-0  
Fax: 00 49-(0) 2 12-88 04-188

REO USA  
3250 North Post Road, Suite 132, Indianapolis  
IN46226, USA  
Tel: 001 317 8991395 Fax: 001 317 8991396



REO (UK) LTD, Units 2 - 4 Callow Hill Road, Craven Arms  
Business Park, Craven Arms, Shropshire SY7 8NT UK  
Tel: 01588 673411 Fax: 01588 672718  
Email: [sales@reo.co.uk](mailto:sales@reo.co.uk) Website: [www.reo.co.uk](http://www.reo.co.uk)

**REO UK LTD**

EN 61000-4-16 and compliance with the EMC Directive	2
What to do when new versions of basic test standards are issued	5
What are 0Hz-150kHz CM disturbances, and how do they arise?	6
The problems that can be caused by CM disturbances up to 150kHz	9
What kind of equipment is covered?	10
Full compliance immunity testing using EN 61000-4-16:2000	12
On-site testing	29
Preventing the tests from causing (or suffering) interference	29
Alternative test methods	31
Correlating alternative test methods with EN 61000-4-16	34
Determining an 'engineering margin'	34
'Test As Real Life' (TARL) for low warranty costs, other financial benefits and safety	35
TARL and real-life 0Hz-150kHz CM disturbance possibilities	37
In-service failures and 0Hz-150kHz CM disturbances	41
References	42

EN 61000-4-16 concerns the immunity of electrical and electronic equipment to conducted common-mode (CM) disturbances (noise currents and voltages) in their external cables, at 0Hz (DC) and over the frequency range 15Hz to 150kHz.

IEC 61000-4-16 [1] has been adopted as the harmonised European standard EN 61000-4-16 [2]. These two standards are available to be called up as basic test methods by product and generic standards listed under the Electromagnetic Compatibility (EMC) Directive, 89/336/EEC [3].

The EN version of 61000-4-16 is technically identical to the IEC document, so this booklet is of use where either standard is required. Since many national tests outside the EU, or purchasing contract requirements, are based on IEC standards, this booklet may also be of use in such situations.

EN/IEC 61000-4-16 is what is known as a 'basic test standard', so when following the self-declaration to standards route to conformity (Article 10.1 in [3]) it need not be listed on an equipment's EMC Declaration of Conformity. Only the relevant generic or product harmonised EMC standards are *required* to be listed. Generic or product standards can call-up EN or IEC 61000-4-16 as one of the test *methods* they employ – but it is always the generic or product standard that sets the test *levels*, test *durations* and functional performance criteria that should at least be tested to allow conformity to be claimed.

At the time of writing no product or generic EMC standards listed under [3] are known to require testing to EN or IEC 61000-4-16 – but future standards (or versions of existing standards) may well do so. Plus of course this basic standard can be useful when specifying the performance of equipment for suppliers, or for manufacturers who want to improve their equipment's real-life reliability.

The relationship between EN 61000-4-16 and the first edition of the EMC Directive (89/336/EEC)

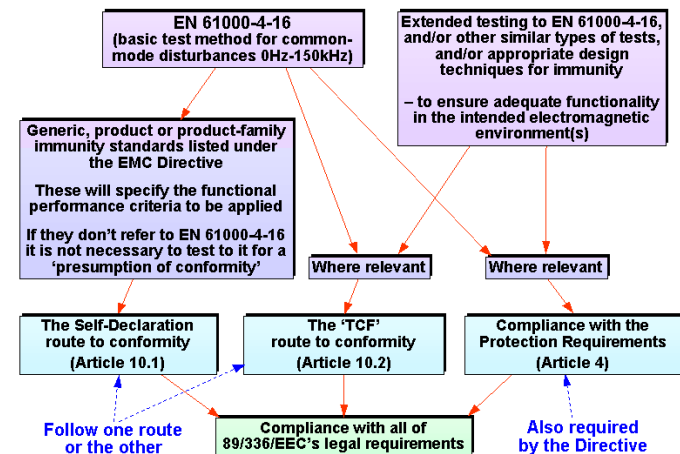

When using the Technical Construction File (TCF) route to conformity with the EMC Directive (Article 10.2 in [3]) it is possible to use EN or IEC 61000-4-16 directly, in which case it *should* be listed on the equipment's EMC Declaration of Conformity. In such cases the equipment manufacturer should assess the electromagnetic (EM) environment of the equipment [4] and ensure that it is designed and/or tested accordingly, so as to comply with the EMC Directive's Protection Requirements (Article 4 of [3]).

Compliance with the EMC Directive's essential Protection Requirements applies *in addition* to the requirement to follow one of the conformity assessment routes (Self-Declaration, Article 10.1; TCF, Article 10.2; or Type Approval, Article 10.4 of [3]). Equipment that passes tests to all relevant product or generic standards that are listed under the EMC Directive, but nevertheless is unreliable or fails in normal use because it is not immune enough for the real-life EM environments in the applications it is intended for – does not comply with the EMC Directives essential Protection Requirements and is therefore illegally CE marked.

So, even when the Self-Declaration Route is being followed, equipment manufacturers are recommended to assess the electromagnetic (EM) environment of the equipment [4] and ensure that it is designed and/or tested to comply with the EMC Directive's Protection Requirements (Article 4 of [3]). Where an item of equipment could be affected by CM disturbances in the range 0Hz to 150kHz in normal operating environments – it may prove necessary to apply EN 61000-4-16 (or similar) in order to comply with the Protection Requirements and hence fully comply with the EMC Directive.

Applying EN 61000-4-16 or similar immunity tests which go beyond the minimum requirements of the EMC Directive's listed product and generic standards can help make equipment more reliable, reduce warranty costs, improve customer satisfaction and reduce exposure to product liability claims. This issue is addressed in the section on 'Test As Real Life', later.

The second edition of the EMC Directive, 2004/108/EC [5], replaces [3] on the 20<sup>th</sup> July 2009. Equipment already being supplied in conformity with 89/336/EEC will be allowed to be supplied until 20<sup>th</sup> July 2009, by which date it too must comply with [5] if it is to continue to be supplied in the EU. Whereas [3] requires the involvement of a Competent Body with all TCFs, [5] effectively allows the TCF route to be used with the *optional* involvement of a Notified Body (the new term for Competent Bodies under [5]).

Like 89/336/EEC, 2004/108/EC [5] also requires equipment to comply with its Protection Requirements, given in its Article 5 and Annex 1, where it sometimes calls them "Essential Requirements". So it is recommended that all equipment manufacturers assess the electromagnetic (EM) environment of their equipment [4] and ensure that it is designed and/or tested accordingly.

Under 2004/108/EC, all 'fixed installations' must comply with its Essential Requirements, and they must also have documentation that shows how this has been achieved using good engineering practices. Equipment manufactured specifically for use at a named 'fixed installation' may not have to comply with any EMC requirements at all – when it is supplied – but testing to EN 61000-4-16 at specified levels could be one of the

### The relationship between EN 61000-4-16 and the second edition of the EMC Directive (2004/108/EC)

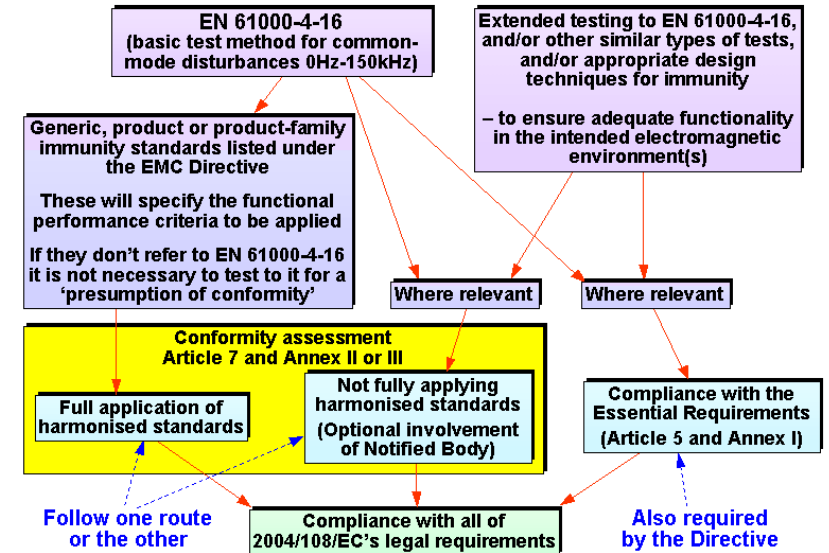

EMC specifications imposed on the supplier by the purchaser, to help ensure that a particular 'fixed installation' complies with the Essential Requirements.

This booklet is part of a series that discusses a number of common EM phenomena in residential (residential, household, etc.), commercial, light industrial and industrial environments, and how they are tested according to appropriate EN standards on emissions and immunity [6]. But other kinds of immunity tests may be required for aerospace, automotive, rail, marine, military, and other special environments.

Some industries have developed their own immunity test standards for EM phenomena below 150kHz, based on their own particular requirements. For example the International Telecommunication

Union publishes the 'ITU-T Recommendations' [7 – 12], which include such tests. There are also a number of such tests in the military EMC standard MIL-STDE-461E [13] and DEF STAN 59-41 [14] and in the aerospace standard RTCA DO-160E [15]. Motor car manufacturers often specify immunity tests with sinewaves below 150kHz, suited to the automobile EM environment, for the electronic sub-assemblies they purchase.

**Important Safety Note:** As a general rule, people whose health depends on the correct operation of pacemakers or other body-worn or implanted electro-medical devices should never go near any EMC immunity tests or their associated test equipment.

### What to do when new versions of the basic test standards are issued

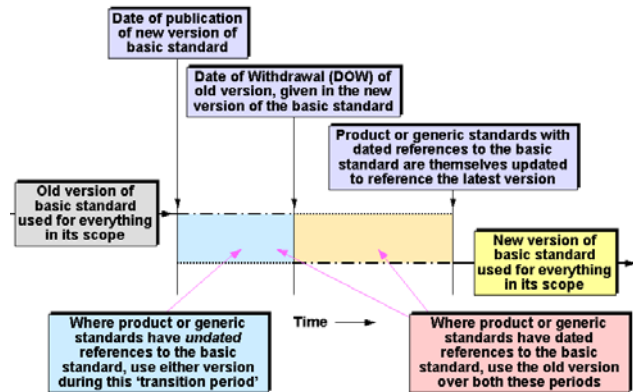

This booklet describes how to apply EN 61000-4-16:1998. Where a generic or product EMC standard requires the use of a basic test method it will specify either a dated reference (e.g. “EN 61000-4-16:1998”), or an undated reference (e.g. “EN 61000-4-16”). If it specifies a *dated* reference, then only this version of the basic test method standard may be used. If it specifies an *undated* reference then the *latest* published version of the standard should be used. (At the time of writing, there are no versions of EN 61000-4-16 other than the 1998 one.)

But it is clearly impractical for manufacturers to rush to test labs to retest all of their types of equipment on the very day a new version is issued, so each new version of an IEC standard includes a date on which it supersedes the previous version. This is the “date of withdrawal” (DOW), and provides a transition period during which manufacturers can choose between using the old or the new versions of the standard for declaring compliance. The DOW is preserved in the EN versions of the IEC standards.

Usually it makes best commercial sense to

test new equipment to the latest version of a standard, retesting older equipment when they are due for retesting anyway, as a result of a design change or upgrade (as long as this happens before the DOW). Some equipment is sold for such short periods of time that they may never need to be retested to any new versions of standards.

A note of caution: the European Commission (EC) has ruled that where Directive compliance is concerned, only dates that are published in the Official Journal of the EU (OJEU) have any relevance, and not any dates put into standards by their committees. This is not a problem in most cases, but basic EMC test standards such as EN 61000-4-16 are never listed in the OJEU. Since DOW dates in the basic standards are not recognised by the EU, there can be no transition period – which is clearly impractical and silly – but this consequence does not seem to have been foreseen by the EC. It is probably less risky to always use the latest version of a basic test standard, except where the regulatory requirements (for the EU or other markets) specify the exact version to be used.

CM voltages and currents are those that affect all of the conductors in a given cable equally, at the same time. For example, if two items of equipment are connected together by a data cable, but one of the items has an earth (ground) potential that is different from the other, then the data cable ports experience the earth/ground potential difference as a CM voltage on all of its conductors at the same time.

The causes of such low-frequency CM disturbances are described in clause 3 and Annex A of EN 61000-4-16. The principal cause is the electrical power source:

- 0Hz (DC), e.g. for telecommunications rooms, server rooms using 'blade servers', etc.
- 16.67Hz, used by some types of electrified railways and tram systems
- 50Hz, used by typical 230/415V low-voltage 'mains' supplies in the UK, Europe, and many other countries
- 60Hz, used by typical 120/240V low-voltage 'mains' supplies in the USA, Japan, Philippines, and countries not supplied at 50Hz.

The power source causes CM voltages and currents to arise through stray coupling, leakage and earth-faults (when a live conductor makes accidental electrical contact with an earthed conductor or structure).

Leakage of electrical power can be caused in a number of ways, for example by:

- Capacitive coupling between cables that are placed in close proximity, when one of them carries the electrical power voltage.

- Inductive coupling between cables that are placed in close proximity, when one of them carries the electrical power current.
- Resistive (sometimes called common-impedance) coupling due to current leaking to the earth/ground, and causing voltage differences to arise between items of equipment as the leakage currents flow in the non-zero impedance of the earth/ground structure.

An extreme example of this occurs in offices where there are large numbers of computers. Safety standards limit the leakage of electrical power into the safety earth/ground of each computer or video monitor to 3.5mA, but with (for example) 3,000 PCs and 3,000 monitors the total current in the building's safety earth/ground structure can be as high as 21A. Some commercial buildings have been measured as having as much as 70A of leakage current in their safety earth/ground due to the use of large numbers of personal computers.

Electrical power leakages create continuous CM voltages and currents – they are present all of the time, although they may vary from time to time as the numbers of items of 'leaky' equipment varies or as cables are moved.

Faults in the electrical power system cause much higher levels of common-impedance coupling – but only for a short time, until the relevant overcurrent protection devices (e.g. fuses, circuit-breakers, etc.) operate to protect the supply network from damage. This is generally assumed to be about 1 second.

### CM noise voltages 0Hz-150kHz due to earth/ground impedance and leakage currents

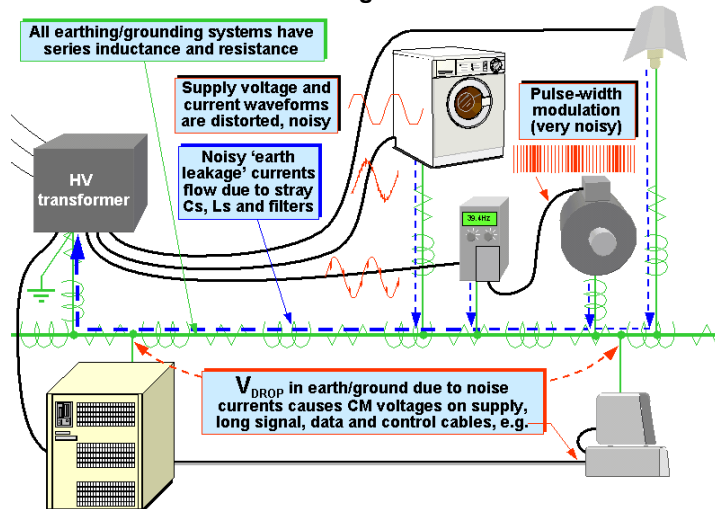

Because of the distortion of the electrical power supply voltage waveform by the currents consumed by electronic and other non-linear loads, the coupling described above is not limited to the fundamental frequency of the supply (e.g. 50Hz) – but includes its harmonics – generally considered to be significant up to 2kHz.

Apart from the electrical power supply, another cause of CM disturbances mentioned by EN 61000-4-16 is power electronic equipment, for example power converters with DC or AC outputs. These employ high currents and voltages at frequencies other than the electrical power supply, and these can also couple into cable ports as a result of stray capacitance, stray mutual inductance, and leakage currents (common-impedance coupling) as described above. Variable-speed AC and DC motor drives can have output frequencies that are below 15Hz, and some of them can be very powerful indeed (e.g. MW) but for some reason EN 61000-4-16 ignores such low frequencies.

EN 61000-4-16 does not mention professional audio systems as a source of CM disturbances. Induction-loop systems for hearing aids (the 'T-coil' setting) in public places generate quite powerful audio-frequency fields up to several kHz, and these have been known to interfere significantly with co-located video systems and other equipment. Powerful speaker systems can also be a source of induced audio frequencies up to 10kHz or more.

The immunity of AC power ports to differential-mode (DM) mains harmonics, interharmonics and signalling voltages is covered by EN 61000-4-13 [6], but there are no standards in the IEC 61000-4 series for immunity to continuous CM or DM disturbances below 150kHz for signal, data or control ports. The immunity of all types of ports to continuous CM disturbances above 150kHz is covered by EN/IEC 61000-4-6 [6].

Faults in the electrical power supply can cause a live power conductor to make

### CM noise voltages 0Hz-150kHz due to 'stray' capacitance and inductance coupling

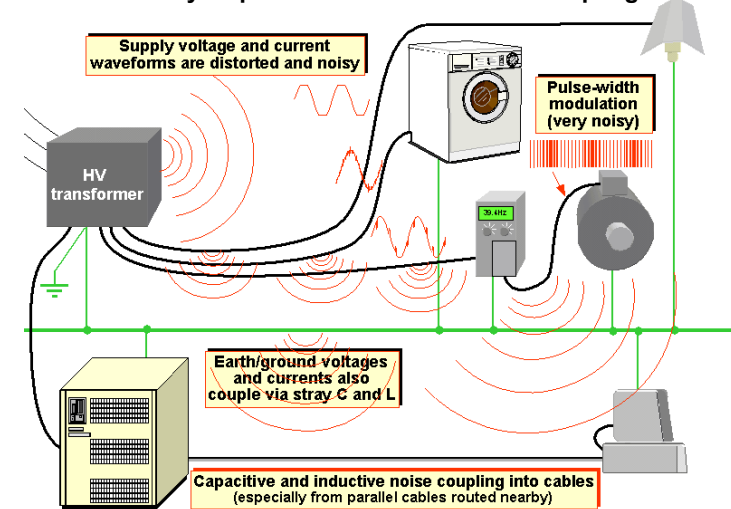

direct contact with a signal, data or control conductor – applying the full supply voltage to it. This is more likely to afflict a single conductor, when it will appear as differential-mode (DM) interference rather than CM. The current consumed by such faults can be lower than what would cause the overcurrent protection devices to operate, so they can remain in place for several minutes, maybe even for days, months or years. This is often called a 'power cross' fault, and is not covered by the tests in EN 61000-4-16, or by any of the tests in the EN/IEC 61000-4 series. However, there are standardised tests used by some telecommunications industries that apply mains power to the telephone wires for at least one minute [7-10].

Emissions of electromagnetic noise at frequencies under 150kHz are not controlled by most of the standards listed under the EMC Directive, and as a result most manufacturers do not bother to control them. For example, the author has

experience of a factory where a new machining centre was installed, but its 50kW variable-speed induction motor drive caused noise at approximately 20kHz to appear on the electricity distribution throughout the site. The level of the noise voltage varied from place to place, presumably due to the different resonances in the site's power distribution system, but in some places was as high as 5Vrms DM plus 1Vrms CM, and this caused existing equipment to malfunction.

The manufacturer of the machining centre had replaced the original mains filter, that had been recommended by the drive supplier, with a cheaper, lighter, more efficient one that met all of the relevant EMC Directive listed emissions standards. But this filter allowed high levels of noise around 20kHz to pollute the site's electricity supply. Replacing the cheaper filter with the one specified by the drive supplier reduced the worst-case noise to 0.5Vrms or less and solved the interference problem.

Variable-speed motor drives are generally more efficient than direct-on-line motor drives, so are rapidly replacing them in industry and commercial sites (e.g. for HVAC). But they all operate their power switching devices at frequencies under 150kHz and so can cause high levels of emissions at such frequencies. Low-cost devices that provide variable control of small electrical motors have recently been developed, and will soon replace almost all of the direct-on-line motor control in household appliances, to save energy. But a very powerful driving force in all of these applications is low purchase cost.

So – ignoring those manufacturers who sell CE marked equipment that does not comply (typically over half of them, according to official figures) – we can expect all of the manufacturers of such devices and the equipment, appliances and systems that incorporate them, to use mains filters that *just about* meet the *minimum* requirements of the emissions standards listed under the EMC Directive (as did the very professional manufacturer of the very costly machining centre in the example above). In other words: they will not even try to control their emissions below 150kHz.

The result of this is that we can expect the electromagnetic environment below 150kHz to become very much noisier, in every type of location, during the next 10 to 15 years. If testing to EN 61000-4-16 was not considered necessary in certain types of application (e.g. residential) in the past, this may no longer be true, and will probably not be true in the near future.

This issue is briefly covered by Clause 3 of EN 61000-4-16, which says that CM disturbances from DC to 150kHz can “...influence the reliable operation of equipment and systems installed in residential areas, industrial areas and electrical plants.” The author does not know why commercial, entertainment, medical, healthcare or military areas were omitted from this list despite suffering from exactly the same problems with CM disturbances below 150kHz.

The DC and low-frequency CM disturbances covered by EN 61000-4-16 cause CM noise to appear in the circuits associated with the cable ports. Depending on the design of these circuits, a proportion of the CM noise is converted into DM noise in the wanted signal. Depending on the circuit design, this DM noise might cause the circuit to function outside of its specification, malfunction, or even suffer permanent damage.

Continuous CM disturbances are not generally expected to cause actual damage to circuits (although they can, and damage to equipment controlled by the circuit might occur). But short-term CM disturbances can have much higher levels so are much more likely to damage circuit components.

It is impossible to be any more precise about the types of errors, malfunctions or damage that can occur due to CM disturbances below 150kHz. This is because they depend entirely on the design of the circuits, the signals they are processing, the functions they are providing, and the applications they are used in.

For example, at one extreme the only effect of CM interference might be an increase in the 'hum' level in an audio signal. But at the other extreme control of a powerful industrial robot could be lost, causing damage to the workpiece and financial loss. (It is assumed that the designers of the robot, and similar equipment and systems, will have taken such possibilities into account in their safety design, so that safety risks are not increased.)

EN 61000-4-16 doesn't cover all possible types and levels of CM disturbances below 150kHz (see the TARK sections below), and some other types or levels can be more harmful to circuit operation and equipment functionality, and also more likely to cause damage to circuit components.

Clause 1 of EN 61000-4-16 does not restrict its scope in any way – so it applies to all kinds of equipment. It says that it tests electrical and electronic equipment by applying CM disturbances to cable connectors intended for power supply, control, signal and communication purposes (EMC immunity standards in the EN/IEC 61000-4 series call all cable connections 'ports').

According to Clause 3, ports that are not likely to be subjected to the EM phenomena covered by EN 61000-4-16 need not be tested. This is considered to mean ports connected to cables that are less than 20 metres long.

Although the frequency range covered by this standard is 0Hz plus 15Hz-150kHz, Clause 1 says that it does not cover the disturbances covered by 400Hz power systems, so equipment intended for use in aircraft and other applications powered by 400Hz generators may need to apply other standards as well (or instead), see [15].

The examples given in Annex B are all based on industrial sites and power plants. EN 61000-4-1 [16] states that testing to EN 61000-4-16 is 'generally not required' in residential, commercial and light industrial areas, which might explain why there are no such examples of such sites given in EN 61000-4-16.

However, the author's opinion is that *any* equipment with long power, signal, data or control cables connected to it can in fact be exposed to CM voltages in the range 0Hz to 150kHz, *wherever* they are used, because the way that electrical and electronic equipment, including the electricity supply network, is generally constructed and installed is similar in all environments.

Mains cables are always longer than 20 metres, so this means that CM voltage immunity tests are always appropriate for the mains ports of equipment. Exclusions may be possible for individual items of equipment that are powered by dedicated mains-isolating transformers (such as are typically used in linear power supplies) – but these might need to have a short-term primary-secondary isolation voltage rating in excess of 3kVrms (see Note 3 to Table 5 of [17]).

Telephone cables connected to the public telephone network are always longer than 20 metres, so all such ports should be tested with CM voltages. The telephone industry has its own standards [7 – 12] for such tests, so EN 61000-4-16 may only need to be applied where its requirements are tougher, or where the telephone industry standards have not been fully applied.

It is easy to find numerous other types of signal, control or data cables that could exceed 20 metres in length, in a variety of residential, commercial, entertainment, agricultural and light industrial environments – for example: burglar alarm systems; access control systems; heating, ventilating, air-conditioning (HVAC) systems; lighting control systems; the internal telephone lines of PABXs; professional audio and video systems, and many other types of audio and video distribution systems.

As mentioned in Section 3 above, because switch-mode power converters (especially variable speed motor drives) will soon become widespread in all environments, including residential, we can expect the electromagnetic environment below 150kHz to become very much noisier in every type of location. If testing to EN 61000-4-16 was not considered necessary

in certain types of application (e.g. residential) in the past, this may no longer be true, and will probably not be true in the near future.

All equipment ports that could be connected to long signal, control or data cables should generally, in the author's opinion, be tested for their immunity to CM voltages from 0Hz to 150kHz. Also, the author generally recommends testing all ports that could be connected to other items of equipment – where that other equipment might connect to signal, control or data cables longer than 20 metres, or be powered from a different electricity supply.

A curious situation arises with regard to power generating and distributing sites. [16] states that testing to EN 61000-4-16 is 'generally not required' in 'special situations' such as power plant, whereas EN 61000-4-16 itself specifically states that it *is* required. It seems clear (to the author at least) that power plants are examples of industrial sites, and also that the levels of electromagnetic disturbances in such sites can be very high indeed, especially those occurring at the frequency of the power supply. So it would seem that [16] is wrong and CM voltage tests up to 150kHz should be applied to all ports of power plant equipment that could be connected to long cables.

## Introduction

This booklet is not a complete recital of everything that is in EN 61000-4-16, only a general guide. Anyone performing tests to this standard should have a copy of the relevant edition, and any relevant amendments, and follow it/them exactly.

## The test stimuli and their levels

Clause 5 of EN 61000-4-16 deals with the test stimuli and their levels. The test stimuli are very simple: either a DC voltage with a low value of AC ripple; or a low-distortion unmodulated sine-wave voltage between 15Hz and 150kHz. In all cases they are applied from a source impedance of 150Ω.

At the frequency of the electrical power supply (either DC, 16.67Hz, 50Hz or 60Hz) the test stimuli are applied as both continuous and short-duration disturbances. Otherwise, over the frequency range 15Hz to 150kHz, the test stimuli are applied as continuous disturbances only.

EN 61000-4-16 has three kinds of tests, and four levels for each test, called Test Levels 1, 2, 3 and 4 respectively. The three kinds of test are:

- a) Continuous CM voltages at the frequency of the electricity supply (see Clause 5.1)
- b) Short-term CM voltages at the frequency of the electricity supply (see Clause 5.1)
- c) Continuous CM voltages over the frequency range 15Hz to 150kHz (see Clause 5.2)

Because EN 61000-4-16 is a basic test standard, it is assumed that the product and generic standards committees will choose the test levels that are appropriate for the equipment within the scope of their

standards. When applying EN 61000-4-16 without the guidance of a product or generic standard, some advice on choosing the appropriate Test Level is given in its Annex B. As mentioned earlier, this advice restricts itself to industrial and power plant applications, so the guidance below extends to residential, commercial and light industrial areas:

- Test Level 1 is considered appropriate for 'well-protected environments', such as a computer room or TV studio, where all electrical power is supplied via isolating transformers and all electrical and electronic equipment is earthed to an earthing/grounding system in the soil underneath.

In the case of DC power, the DC would be derived from batteries supplied by rectifiers supplied via isolating transformers from the AC electrical distribution network, or from an isolated generator.

- Test Level 2 is considered appropriate for 'protected environments', where all electrical and electronic equipment is connected directly to the low voltage mains distribution network (i.e. less than 1kVrms, e.g. 230/400V), and is earthed to an earthing/grounding system in the soil underneath.

The example given is of a control room located in a dedicated building of an industrial or power plant. This level also seems applicable to ports connected to long cables within residential buildings, or within commercial or light industrial premises where high-powered electrical equipment and power converters are not employed.

• Test Level 3 is considered appropriate for 'typical industrial environments', where all electrical and electronic equipment is connected directly to the low or medium (1-33kVrms) voltage mains distribution network, and is earthed to an earthing/grounding system in the soil underneath. Power converters and other high power equipment that injects stray currents into the earthing/grounding system (usually through its filters or the winding-to-chassis capacitance of variable-speed motors) is also assumed to be present.

Some commercial entertainment sites employ electronic power conversion equipment, for example for rapidly moving stages and stage scenery and/or controlling hundreds of kilowatts of lights or sound. Other commercial sites may use powerful electronic converters for varying motor speeds in their heating, ventilating and air-conditioning (HVAC) systems. Test Level 3 seems to be applicable in such cases, and probably also to parts of most electrified transport systems.

• Test Level 4 is for 'severe industrial environments'. The same conditions apply as for Test Level 3, but the typical disturbances are considered to be more severe. The examples given in Annex B are gas-insulated and open-air HV substations and related power plant.

Some heavy industrial sites might be considered to be as severe, for example chlor-alkali process plant, arc furnaces, steel rolling mills, and certain parts of electrified railway or other electrified transport systems.

EN 61000-4-16 does not say so – but the above descriptions assume that the equipment ports are only connected to cables that remain wholly within a single area as described in the above bullet points. The equipment that is connected to each end of the cable concerned is each situated in the same building or protected area.

For instance, if there were two TV studios with protected EM environments, but they were 30m apart, cable ports connected to cables connecting between the two studios would need to be tested with the Test Level that is appropriate to the building in which the studios are located (probably Test Level 2 or 3). Where a cable passes between two different buildings, each with its own low or medium voltage mains distribution network, and its own earthing/grounding to an system in the soil underneath, then even Test Level 4 may not be sufficiently high. (For such cable, ports, the tests in [7-12] may be more appropriate.)

**Test levels for continuous disturbances at the electricity supply frequency**  
(from Table 1 of EN61000-4-16)

Level	Open-circuit test voltage (V rms)
1	1
2	3
3	10
4	30
X	Special (see below)

The stimulus should be applied for long enough to allow complete verification of the equipment's functions

DC tests are applied using each polarity in turn

**Test levels for short duration disturbances at the electricity supply frequency**  
(from Table 2 of EN61000-4-16)

Level	Open-circuit test voltage (V rms)
1	10
2	30
3	100
4	300
X	Special (see below)

The normal duration of this test is 1 second (unless another duration is more appropriate, or is specified by product or generic standard).

The test shall be applied repeatedly until the equipment's functions have been completely verified

DC tests are applied using each polarity in turn

Test Level X is called an 'open' specification. Basic test method standards cannot possibly deal with all eventualities, so the 'X' specifications can be chosen by the product or generic standard committee if they feel they are more appropriate for the type of equipment covered by their standard. The 'X' levels can also be specified by a purchaser (usually in the technical specification that forms part of their contract with their supplier), often based on an EM survey of a particular area or site.

Annex B also mentions that EN 61000-2-5 [17] provides guidance for the applicability of the tests and selection of test levels. Figure 5 of [17] covers induced voltages up to 20kHz – but unfortunately its four Test Levels bear *no resemblance whatsoever* to the four Test Levels in EN 61000-4-16. Figure 8 of [17] covers induced voltages from 10kHz-150kHz, and in this case its Test Levels 2 to 5 correspond with EN 61000-4-16's Test Levels 1 to 4 (respectively), but only over the frequency range 15kHz-150kHz.

**Test levels for continuous disturbances in the frequency range 15Hz to 150kHz**  
(from Table 3 of EN 61000-4-16)

Level	Open-circuit test voltage (V rms)			
	15Hz - 150Hz	150Hz - 1.5kHz	1.5kHz - 15kHz	15kHz - 150kHz
1	1 - 0.1	0.1	0.1 - 1	1
2	3 - 0.3	0.3	0.3 - 3	3
3	10 - 1	1	1 - 10	10
4	30 - 3	3	3 - 30	30
X	Special (see below)	Special (see below)	Special (see below)	Special (see below)

If using an analogue sweep, the sweep rate should not exceed 0.01 decades per second  
If using a digital (stepped) sweep, the step size should not exceed 10% of the previous value.

Slower sweep rates or longer dwell times may be required when testing equipment functions that have long time-constants

**Continuous Test Levels in the range 15Hz to 150kHz**  
(from EN 61000-4-16's Table 3 and figure 2)

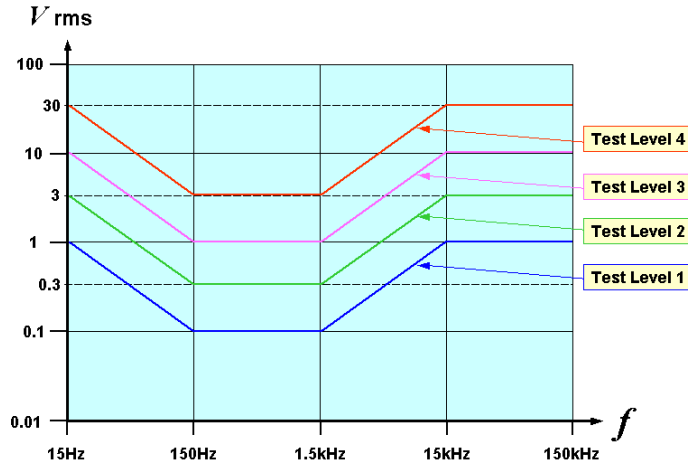

**Continuous Test Levels in the range 50Hz to 150kHz**  
(from EN 61000-2-5's Table 5 and 8)

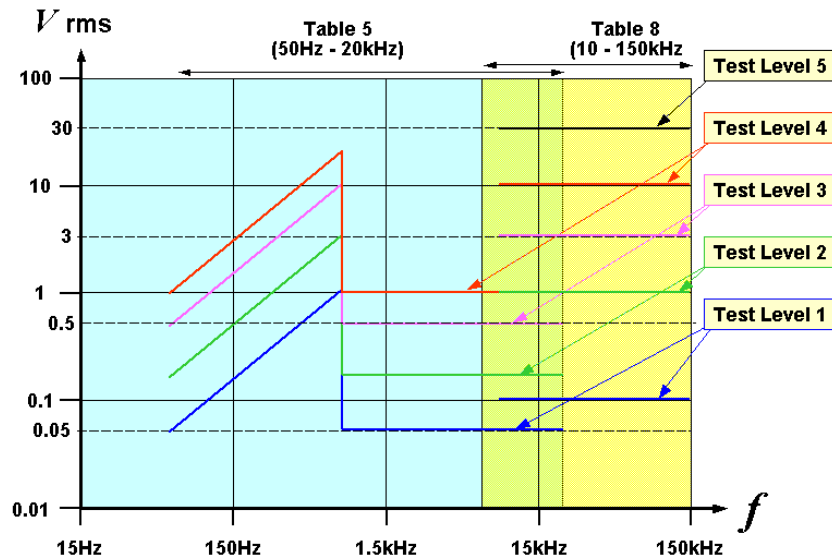

**The test generators**

The test generators used by EN 61000-4-16 are simply DC or sinewave sources. Clause 6 of EN 61000-4-6 specifies the characteristics of the test generators, with separate specifications for the DC and supply frequency generators (for both the continuous and short-term tests), and specifications for the continuous tests from 15Hz to 150kHz. These specifications are not difficult to achieve using ordinary technology, and are not repeated here. If you want to make your own generator – which is not difficult, purchase a copy of the standard.

EN 61000-4-16 says that the generator should have provisions to prevent the emissions of disturbances that, if injected into the power supply network, might influence the test results. But this ignores the possible effect of emissions from the generator's output terminals on the correct operation of the equipment under test (EUT). So this booklet suggests that the test generator should meet the radiated and conducted emission

requirements of the generic emissions standard EN 61326-1 (or else EN 61000-6-3 or EN 55022 Class B), with the conducted emissions being measured on its DC and AC output ports as well as on its input ports.

If you mean to buy a test generator, check that the supplier guarantees its compliance with EN 61000-4-16 and (ideally) supplies it with a calibration certificate from an independent calibration laboratory that is accredited for such calibrations by a national accreditation body (in the UK this is UKAS). You should then check the calibration data against the specification in Clause 6 of the appropriate version of EN 61000-4-16 including any amendments. Also it is a good idea to only purchase equipment that is declared by its manufacturer to comply with the EMC standard EN 61326-1 (or similar standards, such as the generics, or EN 55022 and 55024) for both emissions and immunity, plus EN 61000-3-2 and EN 61000-3-3 (or 3-11). Better still, check the actual EMC test data to improve confidence in the truth of the manufacturer's claims.

**The principle of the test generator for a.c. supply frequency tests**

(from EN 61000-4-16 Table 1 and 2)

(could instead use a signal generator and power amplifier)

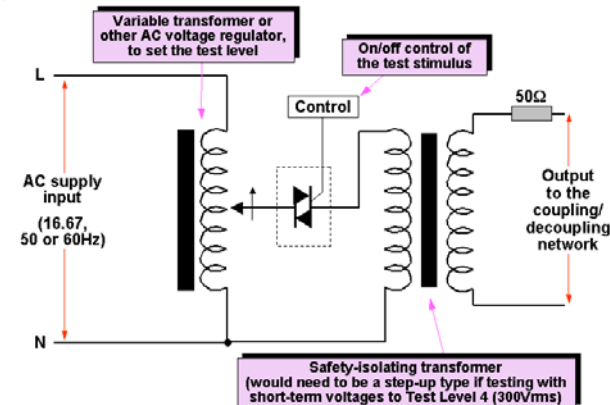

### The principle of the test generator for the d.c. supply tests

(from EN 61000-4-16 Table 1 and 2)

(could instead use a variable d.c. power supply, or a battery with a low-R potentiometer)

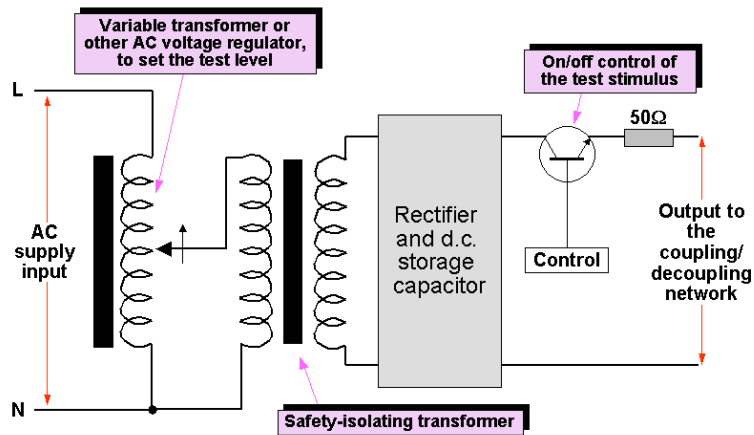

### The principle of the test generator for 15Hz - 150kHz tests

(from EN 61000-4-16 Table 3)

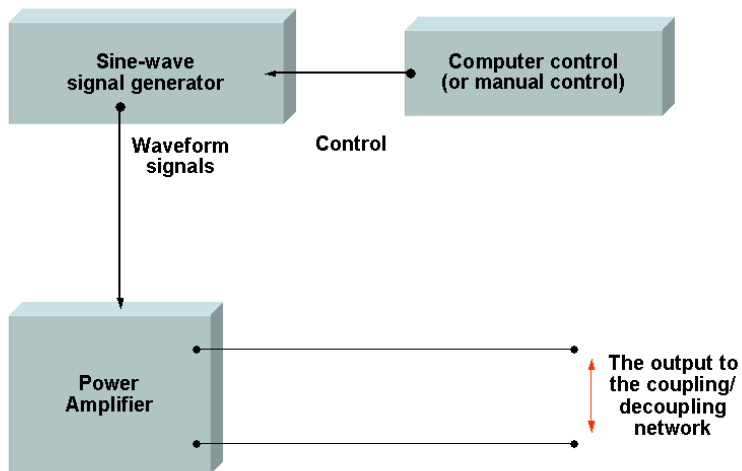

### Examples of variable transformers from REO



### Verifying the test generator

Clause 6.2 of EN 61000-4-16 says that the test generators: "...*must be calibrated or verified for the most essential characteristics*". It says this should be done using a voltage probe and oscilloscope or other equivalent measurement instrumentation with a minimum bandwidth of 1MHz and an accuracy of better than  $\pm 5\%$ .

The essential characteristics that must (note the deliberate use of the word "must" – not 'should' or even 'shall') be calibrated or verified are as follows....

- Output voltage waveform (i.e. DC or sinewave)
- Generator impedance
- Frequency accuracy
- Open-circuit output voltage accuracy
- Rise and fall time of the output voltage (for short-term test stimuli)

Only ever use probes, leads, attenuators and test equipment that are appropriately rated and safety-approved (see the Safety Note below) and calibrated where necessary.

EN 61000-4-16 does not distinguish between *calibration* and *verification*, and does not say how often this mandatory operation should be performed. However, most EMC test laboratory electronic equipment is subjected to annual *calibration*, and most test laboratories rely on an independent 'cal. lab.', but some are equipped to do it themselves and may even be accredited for it.

It is good practice for a calibration laboratory to inform the owner if the test generator was out of specification before they recalibrated it – and if this occurs it will call into question the validity of all of the tests since its previous calibration. To avoid this potential embarrassment, most good test laboratories will *verify* the performance of a test generator several times between its *calibrations*, increasing the rate of *verifications* if the test generator is transported (e.g. when testing on a customer's site instead of in the laboratory) or if it suffers from a physical trauma such as being dropped or having coffee spilt into it. The best testing practices require the test generator's performance to be *verified* before each time an EUT is to be tested, or at least at the start and end of every day on which it is used.

**Safety Note:** When measuring voltages or currents, only use probes and equipment that have been approved by an independent safety testing body (e.g. BSI, VDE, TUV, UL, CSA, etc.) to all of the appropriate parts of EN 61010 for the appropriate 'Measurement Category' (previously known as 'Overvoltage Category' or 'Installation Category'). Measurement Category II is the *minimum* requirement, and Category III or even IV may be required for safety.

### Injecting the test stimulus via a coupling/decoupling network

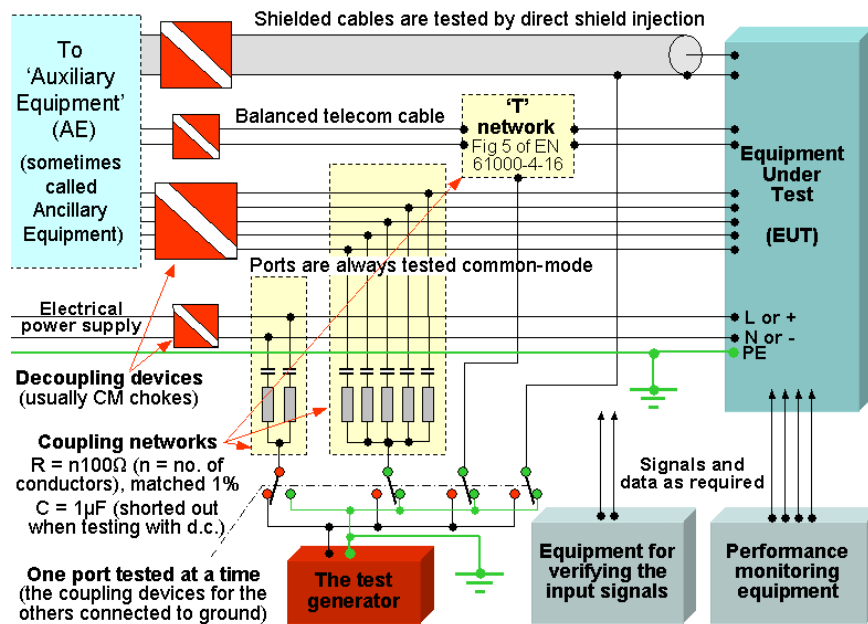

If you don't understand *exactly* what the above paragraph requires, have someone who is qualified and competent in this area sort it out for you. In some installations, special working procedures may be required. Electrical and electronic engineers are killed every year by accidental electric shocks – don't let it be you or your colleagues!

### Coupling/decoupling networks

The test generators inject their output signals (the test stimuli) into the EUT by means of a coupling/decoupling network (CDN), and there will be a different type of CDN for each type of cable port tested. Clause 6.3 and Figures 5 and 6 of EN 61000-4-11 describe the design of these networks, and show how they should be used.

The output impedance of each generator is specified as  $50\Omega$  (see above), and the overall series resistance in each coupling network is  $100\Omega$ , so that the overall source impedance for each of the test stimuli as seen by a port is  $150\Omega$  – but only at frequencies above about  $12\text{kHz}$  where the impedance of the coupling capacitors becomes negligible. Below  $12\text{kHz}$  the overall series impedance rises above  $150\Omega$  due to these capacitors, to approximately  $11\text{k}\Omega$  at  $15\text{Hz}$  for a coupling network for a port with a single conductor. The coupling capacitors are shorted out for the DC tests, so the impedance once again becomes  $150\Omega$ .

Where a cable port has two or more conductors carrying 'single-ended' (i.e. ground-referred) signals, the value of the individual series resistors in the coupling

network is  $n \times 100\Omega$ , so that the  $n$  coupling networks in parallel will result in an overall coupling resistance of  $100\Omega$ . So if the generator's open-circuit output voltage is  $30\text{Vrms}$  (say) – the maximum total current it can output into a port, however many conductors are associated with that port, is  $200\text{mA}$  (above  $12\text{kHz}$ ).

Shielded cables have the output of the test generator connected directly to their shield, so are tested with a source impedance of  $50\Omega$  instead of  $150\Omega$ . As a result, they can be injected with three times as much current, at frequencies above  $12\text{kHz}$ , as the maximum that is possible into a port via a coupling network.

Because there are no coupling capacitors used when connecting to a shield, at frequencies below  $12\text{kHz}$  the shield current could be *much* higher than would be injected by a coupling network. For instance, with a test stimulus of  $30\text{Vrms}$  at  $15\text{Hz}$ , the maximum current injected into a port with a single signal conductor would be  $2.8\text{mA rms}$ , and into 25-way single-ended signal port would be  $69\text{mA rms}$ , but the maximum current that could be injected directly into a shield is  $600\text{mA rms}$ .

Only one port is tested at a time, and during each test all the other ports have the inputs of their coupling networks connected *directly* to the reference ground, thereby creating a common-mode impedance of  $100\Omega$  when testing with DC (coupling capacitors shorted out), and at frequencies above  $10\text{kHz}$ . The author has no idea why EN 61000-4-16 uses a CM impedance of  $150\Omega$  when injecting a test stimulus into a port, but  $100\Omega$  when not testing a port. Apart from anything else, it is not compatible with EN 61000-4-6 [6] at  $150\text{kHz}$ , where the two standards overlap, because this uses  $150\Omega$  for both situations.

Figure 5 of EN 61000-4-16 shows the recommended design for the coupling network for balanced signals (e.g. telephone and microphone cables), which it calls the "T Network". The 'T' is presumably short for 'Telecommunication'. Although this design appears to include a decoupling device – a bifilar wound  $38\text{mH}$  CM choke – in fact such a choke only achieves a CM impedance of about  $12\Omega$  at  $50\text{Hz}$ , and  $3.6\Omega$  at  $15\text{Hz}$  – so it is really intended to help prevent the coupling network from degrading the CM rejection of the EUT's port at frequencies above  $1\text{kHz}$  or so, and is not a decoupling device at all.

Coupling networks are invasive. Similar test standards such as EN 61000-4-6 [6] permit the use of current injection clamps instead of invasive direct injection via CDNs, but such alternatives are not mentioned by EN 61000-4-16, and would not work at DC anyway. Also, the coupling network designs provided are really best suited for low-frequency low-impedance supplies, signals, data and control, and might not be suitable for high-impedance single-ended signals or high-speed data lines whether single-ended or balanced. EN 61000-4-16 recognises that the CDNs can have a bad effect on the signal, control and data signals, so requires these signals to be measured and their new conditions be taken as the reference (which in some circumstances may prove difficult to achieve). Careful design and construction of CDNs might be necessary for some types of signal, data or control ports.

Unlike similar standards such as EN 61000-4-6 [6], EN 61000-4-16 does not include a specification for the performance of its coupling networks. The author has tried to derive a specification from the

designs given in Figures 5 and 6 of the standard, but all that it is possible to say is that the overall series impedance between the test generator's output and the tested port (with all of its conductors connected together) should be...

- $100\Omega \pm 1 - 10\%$  over the range 12kHz to 150kHz
- $100\Omega \pm 1\%$  at DC (with the series capacitors shorted out)
  - and –
- For balanced coupling networks, the balance achieved should be at least 10dB higher than the specified balance for the signal port.
- The voltage withstand capability should be at least 1kVrms at the mains frequency, for at least one minute (less, if it will not be used to test at Level 4 – a safety warning label is recommended to this effect)

Unfortunately, for tests between 15Hz and 12kHz it is impossible to derive a specification for how the overall series impedance varies with frequency. Over this range, the series impedance is dominated by the values of the series capacitors, but there is no consistency in the allocation of capacitance values in the designs shown in Figures 5 and 6 of the standard.

Decoupling devices are required, to protect electrical power supplies from the test stimuli, and also protect the auxiliary equipment (AE) (sometimes called 'ancillary equipment' or 'associated equipment' in other EMC test standards). They are specified by clause 6.3.2.2 of EN 61000-4-16 as having the following characteristics...

- A voltage withstand capability of at least 1kVrms at the mains frequency, for at least one minute (less, if it will not be used to test at Level 4 – a safety warning label is recommended to this effect)
- CM attenuation of at least 60dB over the range 15Hz to 150kHz.

Radio frequency decoupling networks are usually series-connected CM chokes, but at frequencies below 100kHz it becomes increasingly difficult to achieve sufficient attenuation from such devices. 'Shunt' CM chokes (which create a low CM impedance to ground) can be combined with series CM chokes (which create a high CM impedance in series) to improve decoupling performance.

But of course no CM choke can possibly provide any decoupling when testing with DC. Other CM decoupling techniques are necessary for the very low frequencies and DC, including...

- Isolating transformers for signal, data, control or AC power
- Amplifiers
- Opto-isolators

These can be used in conjunction with CM chokes to provide adequate decoupling (sometimes called isolation) from 0Hz to 150kHz.

### Shunt and Series CM chokes

Combining series and shunt chokes together achieves much higher attenuation than is possible with either type on its own

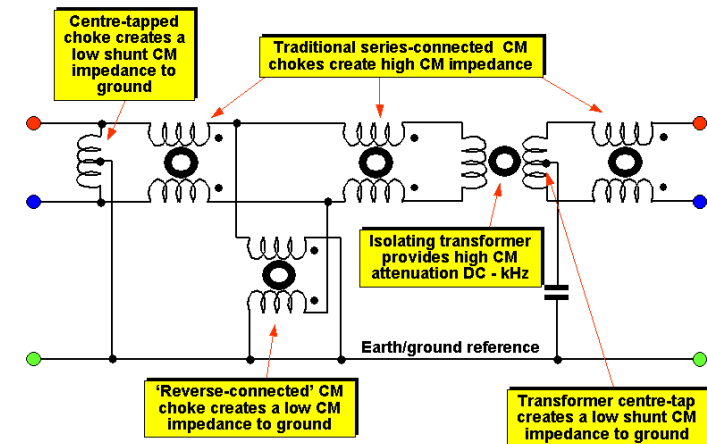

**Safety Note:** It is easy to make perfectly effective coupling and/or decoupling networks yourself, due to the low frequencies and low powers used in these tests – but in normal (dry) laboratory conditions the safety design techniques in EN 61010 should be fully applied where the voltages associated with the cables could exceed 33Vrms, 46.7V peak, or 70V dc. If it is very humid or there is water around, or the possibility of large-area skin contact exists, safety design techniques should be employed at much lower voltages. High currents and energies can cause fire and explosion hazards, so the EN 61010 safety design techniques should be employed whenever the current could exceed 10A, the power could exceed 240VA, or the current that could flow through a person could exceed 0.25mA.

## The test set-up

The test set-up is specified in Clause 7 of EN 61000-4-16, and is very simple. Because this test does not use radio frequencies (RF) it is possible to perform it almost anywhere that a ground plane can be used and still achieve correct results. This makes it a test that is easy and low-cost for a manufacturer to perform in-house, since it does not need shielded rooms, anechoic chambers, costly RF test gear, or test engineers who have RF skills.

The EUT should be earthed/grounded according to its manufacturers installation instructions. The test generator, coupling and decoupling devices should be connected to the same earthing terminal as the EUT, and their earthing/grounding leads should be shorter than 1m.

A ground plane that is connected to the earthing/grounding system could be used instead of a common earthing terminal. It does not matter where the earthing/grounding leads from the EUT, test generator, coupling or decoupling devices connect to the ground plane, but the earthing/grounding leads for the test generator, coupling and decoupling devices should still be shorter than 1m.

The EUT should be arranged and connected according to its installation instructions. AE that is required for the EUT to operate normally should be provided, or replaced by simulators. Where the manufacturer specifies that certain cables be used, they should be used, otherwise unshielded cables suitable for the signals should be used. Where the manufacturer specifies a maximum cable length, this should be used, otherwise the cables should be 20m long.

All of the EUT ports should be connected to appropriate designs of coupling and

decoupling networks, all of them with their inputs grounded – except for the one being tested, which is connected to the output of the test generator. Coupling devices are not required for testing a shielded cable port – its shield is connected directly to the test generator, and earthed/grounded when not being tested. Decoupling devices are not required where an AE, simulator, or power source is itself isolated (i.e. not connected to earth/ground, for example: a battery). Where there are a large number of similar ports, it is only necessary to test one of each type, but some preliminary testing should show that the most susceptible have been chosen.

The EUT should be operated in accordance with the appropriate product or generic standard. Where no product or generic standard applies, the EUT should be tested whilst being operated in each of its modes, connected to all of its loads and AE as appropriate to allow it to operate as intended. The EUT should be loaded to its maximum continuous rating, where appropriate. It is permissible to simulate the AE required to make the EUT work correctly – if the method used will not affect the outcome of the test.

## REO can create custom loads to meet any requirements



## Monitoring the EUT for performance degradation during and after the tests

The functional performance degradation allowed during and after the tests may be specified by product or generic standards. Lacking these, the results should be evaluated according to Clause 9 of EN 61000-4-16 (see later).

Well before the tests are begun, the functional specifications for the EUT should be defined, and serious thought should be given to how to monitor its performance both *during* and *after* the CM disturbance tests, as required by EN 61000-4-16. The performance monitoring should achieve sufficient levels of accuracy and repeatability to be sure that the functional specifications are actually being met.

A professional EMC test laboratory should be able to provide basic electrical test instruments that are immune enough to the influences of EMC immunity tests (check with them first). But where test instruments are provided by the manufacturer (e.g. signal or distortion analysers, display screens, computers, etc.) long periods of time are often spent trying to decide whether it is the EUT or the test equipment that is failing, all the while burning money at premium test laboratory rates.

Also, test laboratories book their time weeks (or even months) in advance, allocating customers testing timeslots that *should* be long enough to perform the required tests. Where customer-supplied functional test equipment is upset by EMC immunity tests, and no quick fixes seem to work, it is possible to run out of time trying to fix the susceptibility of the test equipment, then having to wait a few weeks (maybe months) until another time-slot can be booked to test the EUT.

So determining how to test an EUT's functional specifications well in advance helps avoid costly problems and delays, by organising any special testing arrangements, hiring special equipment, making special cables and leads, providing special power supplies (e.g. hydraulic, pneumatic, high-power 3-phase, etc.), and so on.

## Test conditions

Clause 8.1.1 of EN 61000-4-16 states that tests must be carried out in standard climatic conditions (15-25°C, 25-75% RH; 86-106 kPa), unless specified in the product's specification.

The EM environment in which the test is being conducted should not be so severe as to interfere with the EUT and influence the test results. EMC test laboratories should experience no problems with this requirement, but when performing the test in other locations interference might be a possibility. How to deal with interference at a testing location is discussed in a later section.

## The test plan

Clause 8.2 requires the creation of a test plan, *before* starting to test an EUT. The Test Plan should specify at least the following...

- The type of the test
- The test level
- The test duration (and for short-term tests, the number of applications) to allow complete verification of the EUT's functional performance
- A list of the EUT ports that will be tested

- The operating conditions of the EUT (representative of normal use, remembering that each of the EUT's operational modes are to be tested unless otherwise specified in the product or generic standard that calls up the EN 61000-4-16 test)
- The auxiliary equipment (AE)

In addition, this booklet recommends that the following be included in the test plan...

- The type designation of the EUT
- Details of the cables, coupling and decoupling networks that will be used with each port
- The performance criteria used and defined in the technical specifications
- A description of the test set-up (e.g. the size of any ground plane) to assist if it is necessary to replicate the test exactly
- Descriptions of the design and manufacture of any simulators, special cables/connectors, etc. required to perform the tests
- The descriptions of the equipment used for monitoring the EUT's performance during and after the tests, plus a description of how it is to be set-up and used
- An explanation of how the uncertainties in the functional tests have been dealt with, to be able to determine whether the functional performance specification (see later) really will be achieved (or not) during the tests
- How it will be ensured that all power supply, signal and other functional electrical quantities will be applied within their rated ranges

It is always a good idea to create a test plan well before the planned dates of the tests, to help identify testing and monitoring requirements whilst there still enough time to make changes, hire equipment, construct test leads and AE simulators, write special test software, perform preliminary tests, etc. This helps to avoid wasting time sorting out unforeseen problems whilst paying premium test laboratory rates.

### The test procedure

**Safety Note:** The voltages and 'earth leakage' currents associated with this test can create unsafe situations – adequate safety precautions are essential to avoid risks to operators. If you are not a safety expert or do not know exactly what to do, you must follow the advice of someone who has the necessary knowledge and experience.

Because the CDNs might upset the signals, the test is initially set-up as described above but *without* the coupling and decoupling networks connected, with the equipment required to monitor the operation of the EUT in place. The EUT is then operated in each of its normal modes of operation in turn, fully loaded and connected to AE that simulates its real-life applications. No test stimuli are applied, and the equipment's performance is verified.

Next, the coupling and decoupling networks are connected, and the EUT operated again. This time the signal, control and data signals, and the functional performances are measured to see whether the coupling and decoupling networks have degraded them.

Where the addition of the coupling and decoupling networks has created new

signal or functional conditions, EN 61000-4-16 requires that these “...be considered as references in the evaluation of the test voltage influence” – but in the author's view this might be difficult to achieve in some situations. For instance, if the coupling network degrades a signal's quality, when the test stimulus is applied it might be more likely to cause a test failure (e.g. a 'crashed' microprocessor) than if the signal had the intended quality.

Clause 8 of EN 61000-4-16 includes a note that “A preliminary investigation should be carried out applying the test voltage to the earth port of the EUT in the complete set-up described for type tests.” – but it doesn't say why this should be done, or what advantages are gained by doing it. However, because it tests all of the ports at once, it is a useful technique for determining which modes of operation are more susceptible, and therefore reducing the amount of test time required. If the EUT can be shown to pass the port-by-port tests when operated in the most susceptible modes of operation, it can be argued in the test report that there is no point in testing the other modes.

But when applying an EN 61000-4-16 test generator's output directly to the earth port of the EUT that has more than three unshielded ports, the actual voltage applied to the EUT will generally be much less than is applied when testing on a port-by-port basis – so if no interference is observed at the chosen Test Level, this does *not* mean that the EUT would pass a test with the same test voltage applied to each port individually. This booklet recommends that either the test generator used has a lower output impedance (e.g. 1Ω, with a correspondingly increased output current and power rating), or the test level is increased until interference is

seen to occur with at least one operational mode – which can then be taken to be the most susceptible.

Finally, the test stimuli are applied to each port in turn via its coupling network (with the inputs of the other ports' coupling networks being grounded), with the following tests applied in any convenient order as long as it is documented...

- The continuous tests at the frequency of the electrical supply (for example DC, 16.67, 50 or 60Hz)
- The short-term tests at the frequency of the electrical supply
- The continuous tests over the frequency range 15Hz to 150kHz

The EUT's functional performance should be continuously monitored throughout the tests, and in each case the test duration (and for short-term tests, the number of applications) should be sufficient to allow its complete verification.

This booklet also recommends that the generator's output voltages and voltage waveforms are monitored with an oscilloscope *during* all of the tests to ensure that they remain within specification at all times. Note that the trained human eye can usually only detect sine-wave distortion on an oscilloscope screen at levels of 2% or more.

Unless the EUT's modes of operation are specified by the product or generic standard that calls up EN 61000-4-16, the tests are repeated for each mode unless there is a good technical reason why this is not necessary. For example, a variable speed motor drive may need to be retested if it can be used in different speed control modes (e.g. open-loop, tacho feedback or 'vector'). If any tests are not

carried out for good technical reasons, the reasons should be recorded in the test report (see later).

### Evaluation of the test results

Clause 9 of EN 61000-4-16 requires the EUTs functional performance during and after each test to be assessed against performance specifications defined by its manufacturer (or the person who requested the test). It recommends that the results be classified according to the following scheme...

- a) Normal performance within the limits specified by the manufacturer, requestor or purchaser;
- b) Temporary loss of function or degradation of performance which ceases after the disturbance ceases, and from which the EUT recovers its normal performance, without operator intervention;
- c) Temporary loss of function or degradation of performance, the correction of which requires operator intervention or systems reset;
- d) Loss of function or degradation of performance that is not recoverable, owing to damage to components or software, or loss of data.

This classification is offered by EN 61000-4-16 as a guide to immunity standards committees if they call up this basic test method in their product or generic standards. It is very similar to the 'Performance Criteria' A, B, C (and sometimes D) already commonly used in product immunity standards, which first appeared in the generic immunity standards (EN 50081 and 2, now superseded by the EN 61000-6 series).

Where criteria b) applies, the time interval required for the EUT to recover its full performance is to be recorded in the test report.

Clause 9 also says that the EUT must not become dangerous or unsafe as a result of applying these tests, so this booklet assumes that if any such situation occurs it is recorded as a FAIL result. This booklet also recommends that if the EUT emits any smoke or vapour, or otherwise displays any behaviour that is clearly unacceptable – even if the issue concerned is not covered in the agreed performance specification – then this should also be recorded as a FAIL.

### Determining a PASS or a FAIL

Being a basic test method standard, EN 61000-4-16 cannot specify how to determine whether an EUT has passed or failed its tests – but selling an equipment with a data sheet that says it achieves classification d) (see above) is potentially misleading to an uninformed purchaser, and a joke to any purchaser who is familiar with the standard. Classification d) should never be associated with a PASS result.

Equipment expected to operate automatically and unattended for several hours or longer would probably have to achieve a) or b) for a PASS. But if the equipment was always used by an operator, it might be possible to claim a PASS result when its performance on the immunity tests was c). However, if they could be so very unskilled that they could not be expected to know how to restore normal operation, a) or b) would be required.

If the consequences of momentary errors or non-functionality were considered to be very undesirable, a) might be the only

option. But if the consequences were acceptable, then b) or c) might be considered a PASS.

### Test report

Clause 9 of EN 61000-4-16 states that the test report should include the test conditions and test results.

However, it is good practice in general in EMC immunity testing to include the following in a test report, so this is what is recommended in this booklet:

- The items specified in the test plan (see above)
- Identification of the EUT and any AE, e.g. brand name, product type, serial number. The EUT should be identified in sufficient detail that its hardware and software build state is exactly defined
- Identification of the test equipment, e.g. brand name, product type, serial number
- Any special environmental conditions in which the test was performed, e.g. inside a shielded enclosure
- Any specific conditions that were necessary to enable the test to be performed
- Annotated photographs or drawings of the *actual* test set-up (not a standard figure)
- The performance level(s) defined by the manufacturer, the requestor of the test, or the purchaser
- The performance criteria specified in the generic, product or product-family standard.

(However, where this test was performed despite not being called-up by a generic, product or product-family standard – this booklet recommends that the performance criteria defined by the manufacturer, purchaser, or any other person who requested the test be detailed instead.)

- Any effects on EUT performance observed *during* or *after* the application of the test disturbances, and the duration for which these effects persisted
- The rationale for the pass/fail decision (based on the performance criterion specified in the generic, product or product-family standard, or agreed between the manufacturer and the purchaser, or other person who requested the test)
- Any specific condition of use, for example cable length or type, shielding or grounding, or EUT operating conditions, which were required to achieve compliance with the standard

It also is a good idea to include details of the test generator verification (see above) in the report, plus a judgement on whether the test generator was functioning correctly *before* and *during* the tests, either in the EMC Test Report or in some other QA controlled document. This is so that years later, when all the personnel have changed, it can still be discovered whether a particular test had been done with a fully working generator that had sufficient voltage and current capability for the EUT.

On-site testing to EN 61000-4-16 is easy to do. The only requirements are that the climatic conditions are within the range specified, and also suitable for the EUT, AE, test generator and performance testing equipment, and that the EM environment is not so severe that it interferes with the EUT (making it difficult to tell whether it is the environment or the test that is causing the functional performance to go out of specification).

How to ensure that on-site tests do not suffer from, or cause, interference, is the subject of the next section.

## Preventing the tests from causing (or suffering) interference

**Important Safety Note: Don't forget that interference, especially with aircraft or other vehicular systems; emergency services; some machinery or process control systems; life-support equipment and implanted electronic devices such as pacemakers; can have lethal consequences and appropriate precautions must be taken to make sure that nobody's safety is compromised by EN 61000-4-16 testing. It is also strongly recommended to take appropriate precautions where there is a possibility of significant financial loss being caused by interference during testing.**

Test generators commercially available from well-known EMC test equipment manufacturers would not normally be expected to cause interference problems, but nevertheless it is best to check that they comply with EN 61326-1 (or similar, e.g. EN 61000-6-3 or EN 55022 Class B).

Of course, the EUT must operate properly in the first place, and when testing on a site that suffers from high levels of EM disturbances it may be necessary to use filtering and shielding techniques to be able to distinguish the effects of the ambient noise from the effects of the test. Similarly, where the RF noise emissions (conducted or radiated) from the test generator itself might interfere with the EUT, AE, other test gear or any other equipment, it may be necessary to use filtering and shielding techniques to prevent this from happening.

If either of the above situations arises, there are a number of issues that will need to be taken into account to suppress the interfering frequencies effectively. Suitable filtering and shielding techniques are described in [18].

### A selection of typical REO Filters for AC supplies



### An example of a low-cost shielded tent (courtesy of Hitek Electronic Materials Ltd)



It may be possible to shield the system being tested from incoming RF noise with a shielded tent, and filter each of the cables entering or leaving the tent at least with a large ferrite clamp or number of small clip-on ferrite clamps, placed at the point where the cable penetrates the tent. Ferrishield, Inc. make some very large ferrites that are especially suitable for this purpose: their CS28B2000 has its peak impedance at 300MHz, CS25B2000 at 700MHz, and CS20B2000 at 2.45GHz.

Don't forget that for a shielded tent (or other enclosure, such as mesh over a wooden framework) to be effective usually requires a shielded base that is joined to its shielded walls all around its edges. It might not be enough to simply drape a five-sided shielding tent (or mesh structure) over the EUT.

If working on exposed live equipment, an isolating transformer may be able to be used to help reduce electric shock hazards. It is best to choose special 'high isolation' types of transformers, which have a very low value of primary-to-secondary capacitance; plus choose transformers that are rated for the real-life surge levels (at least 6kV, using the IEC 61000-4-5 test method) to help ensure safety.

High-isolation transformers may also be used to help prevent EMC tests from injecting noise into the mains distribution network of the rest of a site.

### Examples of REO isolating transformers



REO isolating transformer with low primary to secondary capacitances



**Important Safety Note:** Always take all safety precautions when working with hazardous voltages, such as voltages above 25V RMS AC or 35V peak or DC, or with hazardous currents, energies or stored charges. If you are not sure about all of these precautions – obtain and follow the guidance of a qualified and competent electrical health and safety at work person. When constructing equipment that employs hazardous voltages, always fully apply the latest versions of all relevant parts of the EN/IEC 61010 series, at least.

Testing using alternative test generators and/or different types of test waveforms from those specified by EN 61000-4-16 may not be able to give 100% confidence that 'full-compliance' tests to EN 61000-4-16 would be passed. But such 'non-compliant' tests may actually be better than full testing to EN 61000-4-16 for improving the reliability or safety of a equipment if they TARL (test as real-life, see later).

EMC Directive enforcement agencies generally assume that equipment in serial manufacture are tested for continuing EMC compliance on a sampled basis, to show that no accidental changes have occurred in components, design or assembly. The costs of such a QA programme can often be considerably reduced by the use of quick, low-cost, non-compliant tests.

Because these tests do not involve RF, it is easy to develop low-cost alternative test generators that give results useful for development and QA even though they might not fully comply with EN 61000-4-16.

**Important Safety Note:** Always take all safety precautions when working with hazardous voltages, such as voltages above 25V RMS AC or 35V peak or DC, or with hazardous currents, energies or stored charges. If you are not sure about all of these precautions – obtain and follow the guidance of a qualified and competent electrical health and safety at work person. When constructing equipment that employs hazardous voltages, always fully apply the latest versions of all relevant parts of the EN/IEC 61010 series, at least.

There are many possibilities for constructing test generators and creating alternative test methods, and this booklet does not seek to limit the ingenuity of electrical and electronic engineers, always assuming that health and safety is the

An alternative test method using a floating EUT (this is not a method described in EN 61000-4-16)

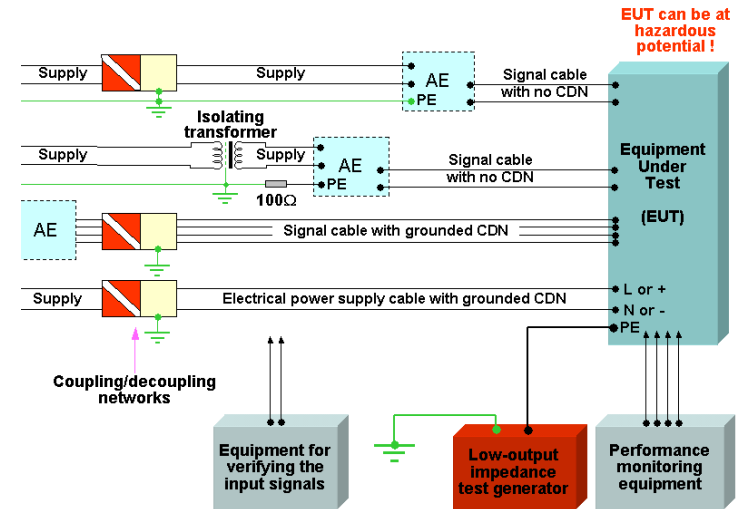

prime concern and that it is ensured by suitably qualified and competent people.

Where CDNs are not practical for some ports for some reason, a possible alternative testing technique may be to 'float' the EUT and apply the CM test stimulus voltage to its floating earth/ground, with respect to the reference earth/ground. This tests all of the ports at once, and the test generator employed should have a very low impedance, say 0.3Ω or less. To have a close relationship with the EN 61000-4-16 method of testing, all of the EUT's port's should be terminated in a CM impedance of 100Ω, which can be achieved by attaching CDNs to the ports for which CDNs are available.

But where CDNs are *not* available, or as an alternative to the use of CDNs, the AE connected to a port can be 'floated' from the reference ground, with its electrical power supplied via a grounded CDN.

Another method is to supply the AE via an isolating transformer and connect a 100Ω resistor from its floating earth/ground to the reference ground. In such cases there should be no decoupling networks between the EUT and the AE, so if functional degradation occurs during the tests, investigations should be undertaken to determine whether it is the EUT or the AE that is the cause.

A simpler version of the above test uses the same set-up but without any CDNs, isolating transformers or 100Ω resistors at all. The EUT is simply set-up as it will be in real-life, but its earth/ground connection connected to the test generator's output instead of to the earth/ground system. For battery-powered or 'double insulated' EUTs, each item of equipment that could be connected to the EUT via a long cable should have its earth/ground terminal driven by the test generator instead.

Where there are cable shields or conductors linking the chassis, frame or enclosure of the EUT to AE that are still connected to the earth/ground system, very high currents can flow, so some modification to the test set-up may be needed to avoid overheating cables or having to use a very powerful generator. Of course, such decoupler-less 'earth/ground driving' tests could interfere with the AE, but you can't have everything!

Some industries have developed their own immunity test standards for EM phenomena below 150kHz, based on their own particular requirements, and their test methods may sometimes be useful – see [7 – 12], [13], [14] and [15].

For all but full compliance and 'pre-compliance' tests, using an uncalibrated test method (i.e. one for which the quantitative measurement is not traceable to the national physical standards) is not very important. But it *is* very important for *all* tests to be *repeatable* – so consistency is always required in the test generator, test methodology and test waveforms and levels. And all of the details of the test set-ups and build states should be carefully recorded in the test documentation. Photographs can be very useful, especially if annotated at the time, and digital cameras make this much easier and less costly than it used to be.

When self-declaring compliance to the EMC Directive using the 'Standards Route' to conformity (Article 10.1 of [3]) – even if alternative test generators have been used to simulate the operating environment and help achieve reliability – passing full compliance tests to EN 61000-4-16 can help avoid the possibility of legal challenges in the future.

But when following the Technical Construction File (TCF) route under 89/336/EEC (or when not fully applying harmonised standards under 2004/108/EC) it may be possible to persuade the mandatory Competent Body (or optional Notified Body) that the alternative tests and test methods applied represent the environment that the equipment is going into, so there is no need to apply EN 61000-4-16 as well. This argument would probably be easier to win for a custom-designed (bespoke) industrial equipment intended for use at a specified site, than it would be for portable equipment or equipment that could be supplied for use in a variety of locations or sites.

When an alternative test generator or method is used for design, development, or troubleshooting after a test failure, repeatability of the test is very important (even though the correlation with EN 61000-4-16 may not be). All such tests will need to follow a procedure that has been carefully worked out to help ensure that adequate repeatability is achieved.

When alternative methods are used as part of a QA programme, or to check variants, upgrades, or small modifications, a 'golden product' is recommended to act as a sort of 'calibration' for the test equipment and test method. Golden product techniques allow low-cost EMC test gear and faster test methods to be used with much more confidence. Refer to section 1.9 of [19] for a detailed description of how to use the golden product correlation method.

If alternative methods are used to gain sufficient confidence for declaring compliance to the EMC Directive, the golden product method is very strongly recommended. Without a golden product or some similar basis for correlating proper EN 61000-4-16 testing with the alternative method actually used, the alternative method might only provide any confidence at all if gross levels of overtesting are applied, and this can result in very expensive equipment.

The closer a test method is to using the same tests and methodology as EN 61000-4-16, the more likely it is that a good correlation will be achieved. Testing with a non-compliant test generator or coupling network might only be able to correlated with the results from a 'proper' EN 61000-4-16 test for a particular build state of a specific equipment. Note that the software version is an important part of the build state – even a simple 'bug-fix' could have a significant effect on EM immunity.

Even having EN 61000-4-16 fully applied by the same accredited EMC test laboratory cannot guarantee that a given EUT will be exposed to *exactly* the same stimuli each time it is tested. But if EMC enforcement agents test an item of equipment, they are unlikely to use the same test laboratory or model of test generator that was used by its manufacturer. So, an 'engineering margin' is recommended, because...

- There can be differences in the test equipment, methods, or in the assessment of the functional test during and after the EMC test, even when applied by the same staff at the same test laboratory – possibly leading to different results
- Coupling and decoupling networks are not completely specified by EN 61000-4-16, so may vary between test laboratories
- Serially-manufactured items of equipment have a variable immunity performance due to component and assembly tolerances

So, when testing an item of equipment to EN 61000-4-16 in a fully compliant manner, it is recommended that additional tests with test levels increased by the chosen 'engineering margin' are also performed, with the equipment still meeting its required functional performance specifications. This will help take care of the above bullet points.

At the time of writing it is understood that no product or generic standards listed under the EMC Directive requires EN 61000-4-16 tests, so how (or if) a manufacturer tests for CM disturbances 0Hz-150kHz is entirely optional. But if EN 61000-4-16 is referenced in a product or generic standard, or if it is called up in a

purchase specification, complex questions arise if alternative test methods are used instead of EN 61000-4-16 for demonstrating compliance. A larger engineering margin is recommended, at least, but how much larger can be hard to determine other than by direct comparison of the effects of both test methods on the identical equipment.

**The need for engineering margins**  
(not to scale)

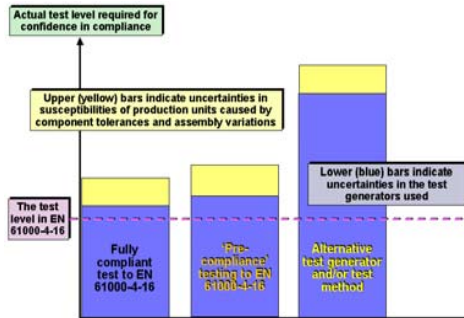

As far as doing the minimum required to achieve a presumption of conformity to the EMC Directive is concerned – saving costs and/or time by using alternative test generators or test methods can lead either to over-engineering or to non-compliance. The additional cost to make the equipment pass the alternative test method with the necessary engineering margins should be weighed against the cost of doing the testing properly.

A big problem with warranty claims and field service is the 'no-fault-found' customer return. Many manufacturers spend considerable amounts of money trying to keep their customers happy, despite not knowing what the cause of the problem is. Many no-fault-found problems appear to be caused by inadequate immunity, but interference events can be hard to repeat, and not many people know enough about EMC to even think of this possible cause, much less correctly identify such problems.

The financial rewards of producing equipment with adequate immunity can be very great indeed, as one UK manufacturer discovered when they spent £100,000 on redesigning their products to comply with the new issues of the EMC Directive's immunity standards around mid-2001, and found to their complete surprise that their new designs saved them £2.7 million in warranty costs *per year*.

But fully complying with any or all of the immunity test standards listed under the EMC Directive, or in the IEC standards catalogue, does not necessarily ensure good enough performance in real life to achieve compliance with the EMC Directive's essential Protection Requirements (see earlier) – or to achieve sufficient confidence in financial risks or safety.

So additional and/or tougher EM immunity tests may need to be applied to an equipment, based upon the real-life EM environment(s) it could be exposed to. This concept is sometimes called 'Test As Real Life' (TARL), and it is vital where high reliability is required for whatever reason. In some applications it will be necessary to base the test programme on the equipment's foreseeable EM

environment(s) over its whole lifetime [4]. This is too large a subject to discuss here – refer to [20] [21] [22] [23] and [24].

If the modified or additional tests can be based on calculations based on known characteristics of the intended application, or on measurements of the intended operational sites over a long enough period to capture the range of CM disturbances that can occur over the range 0Hz-150kHz, this will help avoid both under-engineering and over-engineering.

A problem with any automatic power quality monitoring equipment is that if it is not set up correctly, it will soon fill its memory (or use up all of its paper) recording too-detailed data. If you are not skilled in these matters, and if you don't want to spend time and money going through a learning curve – instead of hiring power quality monitoring equipment from one of the many companies that provide it, hire a power quality consultant instead and have them do the work using their own equipment, analyse the results and provide you with a report.

But if the knowledge required for reasonably accurate TARL cannot be obtained, the manufacturer should decide how far to go with modified or additional testing with 0Hz-150kHz CM disturbances, based upon their sensitivity to warranty costs and customer perceptions of their product. The author knows a large and very successful manufacturer of residential appliances whose EMC testing goes well beyond what is required for compliance with the immunity standards listed under the EMC Directive. The reason they give for this is that their industry is highly competitive, so their profit margins are very small, so they can hardly afford to have any warranty

claims at all. So it is much more cost-effective for them to improve the EM design of their appliances, to reduce warranty costs, even though this adds to their manufacturing costs.

**Safety Note:** When measuring voltages or currents, only use probes and equipment that are proven to comply with the appropriate parts of EN 61010 for the appropriate 'Measurement Category' (previously known as 'Overvoltage Category' or 'Installation Category'). Measurement Category II is the *minimum* requirement, and Category III or even IV may be required for safety.

If you don't understand exactly what this means, have someone who is qualified and competent in this area sort it out for you. In some installations, special working procedures may be required. Electrical and electronic engineers are killed every year by electricity – don't let it be you or your colleagues, or anyone else!

This section discusses a number of situations that show why – to have sufficient confidence in reliable, accurate or safe operation in real life – it may be necessary to modify or add to the requirements in EN 61000-4-16 tests to achieve TARL ('Test As Real Life', see earlier).

There are some other immunity tests that may be useful instead of (or as well as) EN 61000-4-16 where TARL is required. For example [7 – 12] include CM and DM tests below 150kHz that are particularly appropriate for very long cables that connect within and between buildings (such as telephone cables). In the military and aerospace EM environments [13], [14] and [15] include CM and DM tests below 150kHz. Motor car manufacturers also have in-house immunity test standards for frequencies below 150kHz, intended to represent the EM environment within an automobile.

**Safety Note:** The voltages and 'earth leakage' currents associated with the tests described in this booklet can create unsafe situations – adequate safety precautions are essential to avoid risks to operators. If you are not a safety expert or do not know exactly what to do, you must follow the advice of someone who has the necessary knowledge and experience.

### High levels of CM induction from railways and mains power lines

[11] describes how to determine who should be responsible for solving mains-frequency interference problems with telecom installations. Telecom equipment is tested with 60Vrms for up to 15 minutes, according to [12], which uses a test method very similar to EN 61000-4-16, and if the actual interfering voltage on a site is higher than 60Vrms it is the mains power or railway operators' responsibilities to reduce it to 60V or less.

This shows that, where cables can be very long and/or pass outside of buildings or other structures, Test Level 4 in EN 61000-4-16 could very easily be inadequate. The telecom companies appear to have an agreement with the power distribution and railway operators that it is they who should be responsible when CM voltages rise above 60Vrms – but could another type of company reckon on enjoying such co-operation?

So where very long signal, data or control cables are going to be routed in proximity to parallel conductors carrying high currents (e.g. overhead power lines, electrified railways, etc.), the equipment connected to these wires should be tested with *at least* 60Vrms continuous, 600V short-term at the frequency of the AC power, to improve reliability, unless site surveys, calculations or other information shows that this is not necessary.

### Significant levels of DM induction, or port-to-port conduction can occur

It has already been mentioned that EN 61000-4-16 does not test for induced DM disturbances. ITU-T Recommendation K44 [9] includes tests for such phenomena, which it calls 'transverse' instead of DM (ITU-T standards call CM phenomena tests longitudinal).

[9] also includes port-to-port tests, in which the test voltage is applied between two ports, rather than between a port and the earth/ground. This test was developed in response to observed interfering phenomena, but was modified by K20 Amendment 1 [25] to use a test generator that was isolated from the earth/ground, to better simulate real-life problems that had caused high failure rates in a new type of

telecom product using a modern integrated circuit.

Where equipment is connected to very long cables, and especially if these cables extend outside of a building or other structure, tests such as these ITU-T tests may help achieve reliability.

### Fault conditions in public supplies that comply with EN 50160

The highest test level (Level 4) in EN 61000-4-16 for short-term mains frequency disturbances is 300V, but EN 50160 [26] states that in normal electricity supplies in Europe, faults in LV systems can cause a short-term shift in the neutral voltage of as much as the phase voltage, making the live conductor reach phase-to-phase voltage above earth/ground potential – which could be 400Vrms or more. It also says that faults on the high voltage side of the LV distribution transformer can cause overvoltages on the mains supply that will "...generally not exceed 1.5kV". [26] is only concerned with the mains supply and has nothing to say about signal, control or data cables.

Table 5 of [17] says that during a fault condition in an electrical power system, the short-term induced CM voltages can be 3kV (possibly higher, in a circuit that is insulated from earth/ground).

It seems that the mains frequency disturbance test in EN 61000-4-16, even at Test Level 4, is a lot less than what can be expected to occur from time-to-time in real life. So improved reliability can be expected if equipment is designed to pass tests at higher levels.

### Fault conditions in public supplies that do not comply with EN 50160

EN 61000-4-16 seems to be intended to

apply to *developed* countries (but even so is not compatible with some of the disturbance levels listed in [17] or [26]). However, some equipment may be used in countries (or parts of countries) that have a poorer quality of design or construction of electrical power distribution than is normal in Europe, Australia or the USA.

These could all suffer from CM disturbances below 150kHz that may be as bad (or worse) than Test Level 4, and may also suffer from short-term CM disturbances at the electrical supply frequency exceeding the 1.5kV in [26] or the 3kV in Table 5 of [17].

Even in developed countries, there are often areas (usually remote rural ones) where CM disturbances could be worse than those specified in [26]. For example, in Australia there are some remote communities that are powered by a single electrical conductor, with the soil used as the power return conductor (the neutral) as well as the earth. Such communities could experience much higher levels of continuous CM disturbances at the power frequency, and other frequencies below 150kHz, than would normally be the case elsewhere in Australia.

### Potential differences in the earth/ground structure ('earth-lift')

EN 61000-4-16 appears to be intended to cover the situation where the voltage on the chassis or frame of an item of equipment differs from the voltage on the chassis or frame of other items of equipment it is connected to. This is generally called an earth (or ground) potential difference, or 'earth-lift', and leakage currents flowing in the earth/ground structure of the location, site, building, vehicle or whatever cause continuous earth-lift potentials.

Faults in the mains power system can cause much higher earth-lift voltages, but only for as long as it takes their overcurrent protective devices to operate (in building supplied at 230/440V, the fuses or circuit-breakers usually operate within 1 second). Another interesting cause of short-term earth lift at mains power frequencies is during and immediately after a surge (e.g. caused by lightning). If the high voltage during the surge cause an arc to strike to earth/ground, or triggers the operation of a spark-gap or gas-discharge tube (GDT) surge protection device connected to earth/ground, then large mains currents will flow through the arc or the GDT to the earth – causing an earth-lift for as long as the arc persists.

During faults in the power network, or arcs caused by surges, the power-frequency currents that could flow in signal, control and data cables could be as high as several Amps, depending on the impedances and what happens at the equipment at each end.

The source impedance of a potential difference in the earth/ground structure is the impedance of the earth/ground structure itself – below 1kHz it is generally the *resistance* of the structure, which in a typical vehicle or building is usually between 0.1 and  $3\Omega$ .

Many older buildings and other structures are wired using 'single-point earthing' techniques, and if they used earth/ground cables with the same cross-sectional-area as the mains supply conductors, an earth fault could cause an earth-lift of up to 50% of the mains voltage (e.g. up to 120V for a fault in the 240V supply; up to 1.6kV for a fault in a 3.3kV supply). If the earth/ground structure is well meshed as recommended by EN 61000-5-2 and similar EMC good-practice guides (or standards/guides for

the protection of electronic equipment from the effects of lightning), its resistance will be much lower than that of a single-point earthed system, so the earth-lift resulting from an earth fault will be correspondingly lower.

Electrical installers generally only start to become concerned when the earth/ground potential differences at a site exceed 50Vrms, because of the increased risks of electric shock. The author knows of people who have received significant shocks in commercial buildings and theatres when unplugging a cable from an equipment, due to the mains frequency voltage existing between the unplugged connector and the equipment. So it seems like the 30V continuous voltage (Test Level 4) in Table 1 of EN 61000-4-16 can be reached or exceeded in real life, and not only on industrial sites.

Installation advice that used to be given out with a serial data-communication system for use with theatre lighting desks included the requirement not to connect the cable shield at both ends, because “...*the data cable might explode*” due to the earth/ground potential differences in older theatres, and the amount of current they could source.

But the test generators specified by EN 61000-4-16 have a  $50\Omega$  output impedance and are connected via  $100\Omega$  networks, and their output voltages are specified into an open-circuit load. When their load has a low impedance, as might occur when driving the shield of a cable or the earth/ground terminal of a 'floating' EUT, the actual voltage and current they output could be very low indeed. These test generators certainly are not capable of simulating the real-life effects of earth-lift where the earth/ground structure's impedance is low.

Testing the effects of potential differences in the earth/ground system is easy if a powerful enough test generator, with an output impedance of less than  $0.3\Omega$  is available. The EUT is connected to all of its AE without any coupling or decoupling networks, and its earth/ground connection is driven directly by the test generator's output instead of being connected to the reference earth/ground. The voltage is increased to the required level, and either applied continuously, or as bursts lasting about 1 second to simulate a fault.

Although the earth/ground impedance within a structure is generally below  $3\Omega$ , its impedance for cables that connect *between* structures can be between about  $10\Omega$  and  $1k\Omega$ , and testing with a low-impedance generator would not simulate real-life. ITU-T standards covering this situation [7 – 12] vary the resistance in series with the generator to achieve maximum power transfer between the interfering voltage and the tested equipment. EN 61000-4-16's  $150\Omega$  impedance lies within the typical range of the ITU-T tests, but might not be the correct value to give maximum power transfer and test the equipment for real-life reliability.

In the absence of any other information on the mains frequency disturbances in the intended operational environment, to improve reliability this booklet suggests testing with continuous voltages of 10Vrms from 10Hz to 1kHz then 3Vrms up to 150kHz, and also testing with *at least* 60Vrms at 16.67, 50 or 60Hz as appropriate, for at least 10 minutes in each case. Short-term testing should use voltages of *at least* 1.5kV at 16.67, 50 or 60Hz as appropriate, to simulate power network faults. The generator's output should be monitored to check it does not become distorted during the application of

the test voltage. These generators will be quite dangerous – the one for the short-term tests particularly so – so always apply all safety precautions.

### 'Power cross' tests

As was mentioned earlier, faults in electrical power systems are not always line-to-earth, sometimes they are line-to-signal conductor, which is why telephone subscriber equipment is often tested for 'power cross' tests on its telephone cables [7 – 10], in which the full mains voltage is applied for at least one minute.

Such electrical faults can apply the full mains voltage, from what is effectively a  $0\Omega$  impedance (not the  $150\Omega$  assumed in EN 61000-4-16), to signal, data, or control conductors, or to cable shields, either in DM or CM.

Of course, not all equipment is exposed to such faults, and in heavy industry it is usual to route all cables in armour to help prevent such faults. But where it might occur, it is a very severe situation that is not covered by EN 61000-4-16 or any of the other tests in the EN/IEC 61000-4 series.

The ITU-T tests [7 – 10] include power cross test methods. However, it is easy to perform a very crude but power-cross test – taking all safety precautions connect the live lead of the mains supply to each of the external conductors associated with the EUT that could be exposed to such faults, either singly or in combinations. It is usually considered acceptable for the EUT to malfunction during power cross tests as long as it is not damaged and no safety risks are increased significantly. Sometimes it is acceptable for the EUT to be damaged by the test, but no safety risks are ever permitted to occur as a result of such tests.

### Simultaneous EM disturbances

All of the EN/IEC basic EMC test methods only test with one type of disturbance at a time, but in real-life an item of equipment can be exposed to two or more EM disturbances at the same time. Very little work has been done into the effects of simultaneous EM disturbances, but [27] shows that when an EUT is exposed to its full test level of one type of phenomenon (e.g. a radiated RF field of 100MHz at 3V/m) its immunity to a test that it passes perfectly well when applied on its own (e.g. fast transient bursts at 2kV) can be very severely compromised. Another transient event that might happen when an RF field (for example) is simultaneously present is an electrostatic discharge from someone's fingers.

So where a type of equipment is to be installed in areas where there is a continuous exposure to a reasonably high level of an EM phenomenon (e.g. CM disturbances between 0Hz and 150kHz) its immunity to transient disturbances – such as a fast transient burst or electrostatic discharge – might be compromised. TARL techniques would seem to require testing with the transient disturbances in the presence of the continuous EM phenomenon, but some analysis might allow individual tests to be applied at higher levels to avoid a lengthy (and expensive) test programme.

See [6] for useful booklets describing a wide range of other EMC phenomena and their test methods.

If it is suspected that CM disturbances in the range 0Hz-150kHz could be a cause of malfunctions or failures in the field, a survey with appropriate power quality measuring instruments can discover what power disturbances are occurring and whether they correlate with the failures. The instruments used are generally data-logging instruments that can be left for days (maybe weeks) unattended and automatically record details of the disturbances that have occurred over that period. It is rare to know in advance exactly what the cause of a problem is, so it is normal to survey a number of other power quality parameters, as well as 0Hz-150kHz CM disturbances, to try to correlate the likely EM disturbances with the failures that are occurring.

It helps to correlate disturbances with failures if one channel of the survey instrument can monitor something about the equipment that is suffering the problem, that indicates whether the fault has occurred or not. Then when the survey instrument's record is analysed later on, the time stamp on the event that marks the failure of the equipment can be compared with the time stamps on the disturbances that were detected, to see what EM disturbance is most likely to have caused the fault.

Where the failing equipment cannot be monitored automatically, it may be possible to have its operator, or someone else, note the date and time when it fails, for eventual correlation with the power quality survey results. If the equipment is normally unattended, it should at least be checked on a regular basis to see if it has failed or not, and the date and time noted once again. The period between checks should be no more than half of the normal time between failures, and even more

frequent checking helps achieve better correlation with the measured disturbances.

A problem with any automatic power quality monitoring equipment is that if it is not set up correctly, it can soon fill its memory (or use up all of its paper) recording too-detailed data. If you are not skilled in these matters, and if you don't want to spend time and money going through a learning curve – instead of hiring power quality monitoring equipment from one of the many companies that provide it – hire a power quality consultant instead and have them do the work using their own equipment, analyse the results and produce a report.

Where the failure rate is low (e.g. once per month) a site survey to try to locate the cause of a problem could take a very long time. But an experienced EM engineer might already have an idea of what type of EM disturbance is the most likely cause of the failures, and after learning about the site and the other equipment installed on it might already have a good idea of what is the most likely source of that disturbance. The engineer might then be able to suggest ways of creating the EM disturbance in question (rather than wait for it to occur naturally) to see if it does indeed cause the failure. This can save a great deal of time.

[1] IEC 61000-4-16:1998, “*Electromagnetic Compatibility (EMC) – Part 4-16: Testing and measurement techniques – Test for immunity to conducted, common mode disturbances in the frequency range 0 Hz to 150 kHz*”.

[2] EN 61000-4-16:1998, “*Electromagnetic Compatibility (EMC) – Part 4-16: Testing and measurement techniques – Test for immunity to conducted, common mode disturbances in the frequency range 0 Hz to 150 kHz*”.

[3] European Union Directive 89/336/EEC (as amended) on Electromagnetic Compatibility. The Directive's official EU homepage includes a downloadable version of the current EMC Directive and its successor; a table of all the EN standards listed under the Directive; a guidance document on how to apply the Directive; lists of appointed EMC Competent Bodies; etc., all at: [http://europa.eu.int/comm/enterprise/electr\\_equipment/emc/index.htm](http://europa.eu.int/comm/enterprise/electr_equipment/emc/index.htm).

[4] “*Assessing an Electromagnetic Environment*”, Keith Armstrong, downloadable from the ‘*Publications and Downloads*’ page at <http://www.cherryclough.com>.

[5] European Union Directive 2004/108/EC on Electromagnetic Compatibility (2<sup>nd</sup> Edition), from: [http://europa.eu.int/lex/lex/LexUriServ/site/en/oj/2004/l\\_390/l\\_39020041231en00240037.pdf](http://europa.eu.int/lex/lex/LexUriServ/site/en/oj/2004/l_390/l_39020041231en00240037.pdf)

[6] A number of REO booklets on other types of EM disturbances and their corresponding EN test standards can be downloaded from <http://www.reo.co.uk/guides/>, or ordered as paper booklets.

[7] ITU-T Recommendation K20, “*Resistibility of telecommunication equipment installed in a telecommunications centre to overvoltages and overcurrents*” available from <http://www.itu.int/ITU-T/publications/recs.html>, click on “K Protection against interference” then scroll down and click on the ‘K’ number you want to buy.

[8] ITU-T Recommendation K21, “*Resistibility of telecommunication equipment installed in customer premises to overvoltages and overcurrents*”, see [7] for how to download a copy.

[9] ITU-T Recommendation K44, “*Resistibility tests for telecommunication equipment exposed to overvoltages and overcurrents – Basic Recommendation*”, see [7] for how to download a copy.

[10] ITU-T Recommendation K45, “*Resistibility of telecommunication equipment installed in the access and trunk networks to overvoltages and overcurrents*”, see [7] for how to download a copy.

[11] ITU-T Recommendation K53, “*Values of induced voltages on telecommunication installations to establish telecom and a.c. power and railway operators responsibilities*”, see [7] for how to download a copy.

[12] ITU-T Recommendation K54, “*Conducted immunity test method and level at fundamental power frequencies*”, see [7] for how to download a copy.

[13] DEF STAN 59-41, British Defence EMC standards, visit <http://www.dstan.mod.uk>, click on “Standards” then follow the instructions to download the appropriate parts.

[14] MIL-STD-461E, US Military EMC standards, the official site is <http://www.astimage.daps.dla.mil>, but if this doesn't work the Google search engine ([www.google.com](http://www.google.com)) will find URLs where you can download them for free, for example (at the time of writing) <http://www.multilek.ca/Specifications.htm>.

[15] “*Environmental Conditions and Test Procedures for Airborne Equipment*”, DO-160E produced by RTCA and available via [www.rtca.org](http://www.rtca.org). ED14E (produced by EUROCAE) is identical.

[16] EN/IEC 61000-4-1:2000 “*Electromagnetic Compatibility (EMC) Part 4-1: Testing and measurement techniques – Overview of IEC 61000-4 series*”

[17] EN 61000-2-5 “*Electromagnetic Compatibility (EMC) – Part 2: Environment – Section 5: Classification of electromagnetic environments Basic EMC publication*”

[18] “*EMC for Systems and Installations – Part 4 – Filtering and Shielding*”, Keith Armstrong, EMC & Compliance Journal, August 2000, pages 17-26, download it from: [http://www.compliance-club.com/keith\\_armstrong.asp](http://www.compliance-club.com/keith_armstrong.asp).

[19] “*EMC Testing Part 1 – Radiated Emissions*”, Tim Williams and Keith Armstrong, EMC & Compliance Journal February 2001, pp 27-39. On-line at [http://www.compliance-club.com/keith\\_armstrong.asp](http://www.compliance-club.com/keith_armstrong.asp).

[20] The IEE's 2000 guide: “*EMC & Functional Safety*”, can be downloaded as a 'Core' document plus nine 'Industry Annexes' from <http://www.iee.org/Policy/Areas/Emc/index.cfm>. It is recommended that everyone downloads the Core document and at least reads its first few pages. Complying with this IEE guide could reduce exposure to liability claims.

[21] “*EMC-Related Functional Safety – An Update*”, Keith Armstrong, EMC & Compliance Journal, Issue No. 44, January 2003, pp 24-30, on-line at: [http://www.compliance-club.com/keith\\_armstrong.asp](http://www.compliance-club.com/keith_armstrong.asp).

[22] “*Why EMC testing is Inadequate for Functional Safety*”, Keith Armstrong, IEEE 2004 International EMC Symposium, Santa Clara, August 9-13 2004, ISBN 0-7803-8443-1, pp 145-149. Also: Conformity magazine, March 2005 pp 15-23, downloadable via <http://www.conformity.com>.

[23] “*The IEE's Training Course on EMC for Functional Safety (also for high-reliability and legal metrology)*”, visit <http://www.iee.org> for their event calendar to check the date of the next course. If no courses are listed contact the IEE's Functional Safety Professional Network (via the same IEE homepage) and ask.

[24] “*Specifying Lifecycle Electromagnetic and Physical Environments – to Help Design and Test for EMC for Functional Safety*”, Keith Armstrong, IEEE 2005 International EMC Symposium, Chicago, August 9-13 2005.

[25] ITU-T Recommendation K20, Amendment 1 (11/2004) “*Resistibility of telecommunication equipment installed in a telecommunications centre to overvoltages and overcurrents. Amendment 1: New Appendix I – Floating transverse power induction and earth potential rise test for ports connected to external symmetric pair cables*”, see [7] for how to download a copy.

[26] EN 50160:1999 “*Voltage characteristics of electricity supplied by public distribution systems*”

[27] “*Combined Effects of Several, Simultaneous, EMI Couplings*”, Michel Mardiguian, 2000 IEEE International Symposium on EMC, Washington DC, August 21-25 2000, ISBN 0-7803-5680-2, pp. 181-184.

IEC standards may be purchased with a credit card from the on-line bookstore at <http://www.iec.ch>, and many of them can be delivered by email within the hour.

EN standards may only be purchased from EU member state national standards bodies (e.g. BSI in the UK and AFNOR in France).

Both EN and IEC standards may be purchased from the British Standards Institution (BSI) at: [orders@bsi-global.com](mailto:orders@bsi-global.com). To enquire about a standard or other standard-based services call BSI Customer Services on +44 (0)20 8996 9001 or e-mail them at [cservices@bsi-global.com](mailto:cservices@bsi-global.com)



**Keith Armstrong from Cherry Clough Consultants**

*This guide is one of a series. Email us at [main@reo.co.uk](mailto:main@reo.co.uk) if you would like to receive all of our mini guides and to be entered onto our mailing list*

Keith Armstrong graduated in electrical engineering with a B.Sc (Hons.) from Imperial College London in 1972, majoring in analogue circuit design and electromagnetic field theory, with a Upper Second Class Honours (Cum Laude). Much of his life since then has involved controlling real-life interference problems in high-technology products, systems, and installations, for a variety of companies and organisations in a range of industries.

Keith has been a Chartered Electrical Engineer (UK) since 1978, a Group 1 European Engineer since 1988, and has written and presented a great many papers on EMC. He is a past chairman of the IEE's Professional Group (E2) on Electromagnetic Compatibility, is a member of the IEEE's EMC Society, and chairs the IEE's Working Group on 'EMC and Functional Safety'.

Contact: Keith Armstrong by email at [keith.armstrong@cherryclough.com](mailto:keith.armstrong@cherryclough.com) or visit the Cherry Clough website [www.cherryclough.com](http://www.cherryclough.com)

REO is an original manufacturer of high quality power equipment, including electronic controllers, components and electrical regulators, all backed by the application expertise demanded by specialised, industrial sectors, such as .....

Controllers designed specifically for use in the parts and materials handling industry, together with a wide range of electromagnets for driving vibratory feeders.

Power controllers for adjusting and regulating voltage, current, frequency or power, as well as its long established variable transformers (variacs) up to 1MVA and sliding resistors of all types. These are complemented by a range of modern, electronic, variable power supplies.

Components for adapting variable speed drives employed in non-standard applications; including inductors, EMC filters and braking resistors. The range of inductive devices extends into railway components for electrical traction and rolling stock, which includes chokes and high-frequency transformers.

Special, toroidal transformers used in safety, medical and energy-saving systems plus high-frequency transformers used in switch-mode power supplies.

Test equipment such as load banks and variable AC/DC power supplies.

REO actively searches for development partners, particularly in niche markets, and considers this to be an essential stimulus for creating new and original ideas.

#### A selection of REO chokes



#### Typical REO common-mode chokes



#### Typical REO differential-mode chokes

## REO - Market Sectors



Automation Systems

Controllers for vibratory feeders



Communication Systems

Field bus and gsm



Train Systems

Chokes and high frequency transformers



Inductive Components

Chokes, resistors and transformers



Classics

Rheostats and variacs



Renewable Systems

Solar transformers

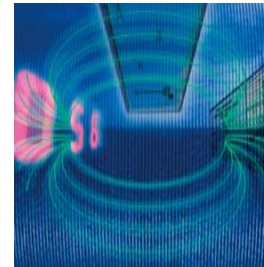

Test Systems

Power supplies and load banks



Power Electronics

Phase-angle and frequency controllers

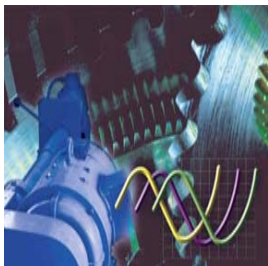

Motor Control Systems

Soft-starts

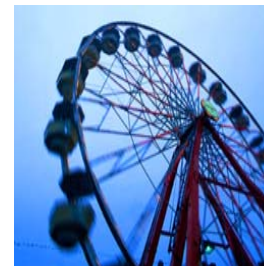

Drive Systems

Filters and braking resistors



Medical Systems

Medical Transformers