

Operating Instructions

**REOTRON**  
**MEW 2-S-60/400-DP 24**

2-Stage Thyristor Power Controller  
with Voltage Regulation

## Technical Information for the User

This description contains the necessary information for the correct application of the product described below. It is intended for use by technically qualified personal.

Qualified personnel are persons who, because of their training, experience and position as well as their knowledge of appropriate standards, regulations, health and safety requirements and working conditions, are authorised to be responsible for the safety of the equipment, at all times, whilst carrying out their normal duties and are therefore aware of, and can report, possible hazards (Definition of specialist according to IEC 364).

### Safety Instructions

The following instructions are provided for the personal safety of operators and also for the protection of the described product and connected equipment.



#### Warning!

Hazardous Voltage

Failure to observe can kill, cause serious injury or damage

- Isolate from mains before installation or dismantling work, as well as for fuse changes or post installation modifications.
- Observe the prescribed accident prevention and safety rules for the specific application.
- Before putting into operation check if the rated voltage for the unit conforms with the local supply voltage.
- Emergency stop devices must be provided for all applications. Operation of the emergency stop must inhibit any further uncontrolled operation.
- **Electrical connections must be covered**
- **Earth bonding must be tested prior to operation**
- 

### Prescribed Use

The units described herein are electrically powered for use in industrial applications. They are designed for power adjustment of resistive or inductive loads

<b>Contents</b>	<b>Page</b>
Technical Information for the User	1
1.0 General	3
2.0 Functional Description	3
2.1 Control inputs and output (interface)	4
3.0 Construction	5
4.0 Technical Data	5
5.0 Ordering Codes	5
6.0 Manual Control Settings	6
6.1 Operation	6
6.1.1 Adjustment	6
6.2 Adjustment Procedure	6
6.3 Display Messages	7
6.4 Error Messages	7
7.0 Settings	8
8.0 Setting up instructions	9
8.1 Internal setpoint	9
8.2 Unit configuration	9
8.3 Settings	10
8.4 Select Interface Protocol	10
8.5 Save current settings	10
8.6 Restore Parameter Settings	11
8.7 Hide parameter menus	11
9.0 Profibus-DP	12
9.1 Operation with Interface	12
9.2 Technical Data for Profibus Interface	12
9.3 GSD File	12
9.4 Bus Operating Mode	13
9.5 Addressing	13
10.0 Operation with Interbus S	13
11.0 Programming for Bus operation	14
11.1.1 Send to Controller	14
11.1.2 Reply from Controller	14
11.2 Parameter Operation	15
11.2.1 Creating parameter address's and values	15
11.2.2 Send Write Enable	16
11.2.3 Receive, Acknowledge Write Enable	16
11.2.4 Send Parameter	16
12.0 Parameter Table	17
13.0 Example of bus communication	18
13.1 Normal mode	18
13.2 Parameter Operation	18
13.3 RESET Controller	19
14.0 Controls	20
14.1 INTERBUS-S Interface	20
14.2 PROFIBUS-DP Interface	21
15.0 Schematic Circuit	22
16.0 Connection Diagram	23
17.0 Dimensions	26
18.0 Mounting	27

## 1.0 General

The REOTRON D-MEW thyristor unit is a microprocessor controller for adjusting the power to resistive and inductive loads. It has a dual output and operates as a voltage regulator. Basically the unit comprises an input isolator, inverse parallel thyristors, control and regulation electronics and an optional field bus interface. The units have a variable voltage output with underlying current regulation (current limiting). The voltage set point and all specific control conditions can be adjusted from an analogue source (potentiometer, signal voltage 0...+10V, signal current 0(4)...20mA) and also a fieldbus interface, either PROFIBUS or INTERBUS. The required feedback signal can be generated from a current or voltage transformer. The maximum current limit of the unit cannot be overridden by the phase angle adjustment, in any regulation modes. Furthermore, it is possible to operate with greatly varying loads  $R_{cold}/R_{warm}$  and the unit is protected against overloads

## 2.0 Functional Description

The thyristor unit comprises a regulator for current limiting i.e. a voltage regulator. The regulation is controlled by internal software. A set point determines the output voltage and this is held constant by a regulation circuit. Therefore, load or supply voltage changes have no influence on the output voltage. The maximum current limit cannot be overridden in this operating mode (current limiting). An LED display indicates if the limit  $I_{max}$  or maximum adjustment have been reached.

The voltage regulation remains in control providing the current level remains below the set limit. When the current limit is reached the current regulator has priority and the output voltage is reduced.

During voltage regulation the switch-on rise, time of the individual mains half waves, is minimised (especially during phase angle control), thereby ensuring that a sinusoidal current waveform is delivered to the load. The available adjustment range is contained within the second stage. The relative change of the first and second stages is self controlling, irrespective of the set point setting.

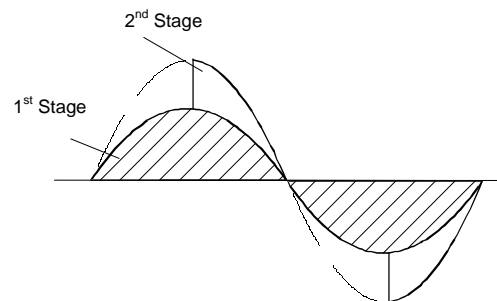

### Current feedback

The current is measured, in one phase, with an external CT and a load resistor is used to provide the required output value. The internal microprocessor determines the effective value of the output current and makes adjustments through a PI loop.

### Voltage feedback

The effective voltage signal must be provided externally. It is converted in an analogue input stage and then fed to the internal microprocessor. The effective value is thus determined and applied used for PI regulation using software.

### Current regulator

This is a software driven control circuit with PI characteristics. The unit's maximum output current is the same as the unit's factory set, current rating. The current limit adjustment, up to the rated current, can be determined from the set point input (corresponding to 10V =  $I_{max}$ , or FFFFh =  $I_{max}$  for fieldbus operation).

### Voltage regulator

This is a software driven control circuit with PI characteristics. The unit's maximum output voltage is factory set to correspond to a 100% feedback signal (10V).

### Pulse timing0

The firing pulses, used to control the thyristors, are microprocessor generated and pass through an amplifier to a pulse transformer. The secondary side of the pulse transformer directly controls the thyristor.

### Temperature monitoring

A temperature sensor is fitted into the heat sink to monitor its temperature. This switches off the thyristor regulator when the temperature reaches 80 °C (reset by switching off and on again). A over temperature error message is displayed and a status word is sent over the field bus interface.

## 2.1 Control inputs and output (interface)

The unit can be controlled from analogue control signals or a PROFIBUS interface.

### Inputs

Output Voltage set point  
Output Current set point (current limit)  
Enable (On/Off)  
Isolator (On/Off)

### Outputs

Effective Voltage  
Effective Current  
Fault Relay

Alternatively, the unit can operate as a slave through an INTERBUS or PROFIBUS interface. In normal operation the output voltage, set-point is provided by a PLC and the unit status, ready or fault, is fed back from outputs. The interface can be configured in an additional parameter setting mode. An external, 24 VDC power supply is required for the interface.

**Profibus versions are supplied with the appropriate GSD file.**

### 3.0 Construction

The REOTRON D-MEW thyristor controller is a completely functional, compact, unit. It has been designed for building into an enclosure. All connections for the supply, power output, feedback signals and the supply for the isolator are made through screw terminals.

A touch panel with and LED display and setting up keys is incorporated in the front panel. There are connectors provided for analogue signals and a field bus interface and also an overload trip.

Inside the unit there is a printed circuit, control card and a power card, comprising the semiconductors, firing and regulating circuits and the system power supply.

There is a further pcb for the INTERBUS or PROFIBUS interface. The interface requires a separate external 24V supply. The internal boards are interconnected through their own internal serial interfaces.

### 4.0 Technical Data

Type:	REOTRON MEW 2-S-60/400-DP 24	REOTRON MEW 2-S-60/400-IS 24
ID-Nr.:	6300 02	6300 03
Input voltage	1 AC 400V, 50 / 60 Hz	
Output voltage:	0...400 V (subject to volt losses across the semiconductors)	
Output current	1... max. 60 A	
Feedback voltage	0...5 V eff., AC	
Fault relay rating:	1 AC 230 V, 50 / 60 Hz	
Serial Protocol	PROFIBUS-DP	INTERBUS-S 2-Line Fernbus / 9 pole. connector
ID-CODE:		33 HEX -
Spannungsversorgung Schnittstelle:	24 V, DC 0,2 mA	
Operating Temperature	0...45° C	
Dimensions. (t x b x h) mm	500 x 220 x 100	

### 5.0 Ordering Codes

**REOTRON MEW 2-S-60/400-DP 24** (Profibus-DP)  
**REOTRON MEW 2-S-60/400-IS 24** (INTERBUS-S)

## 6.0 Manual Control Settings

Manual settings are entered using the display in the front panel. Below are the settings for manual and fieldbus operation and also the setting of limits.

### 6.1 Operation

The six buttons and a LED display found in the front panel, are used for operating and setting up the unit. All operating methods and adjustable parameters can be set up through this panel.

**The “I” and “O” buttons are used for switching the unit ON and OFF, however, these do not provide mains isolation, they simply inhibit the power semiconductors**

The “P”, “F” and “Cursor Buttons” are used for parameter adjustment. Parameters are set by using menu controls which are called up by entering operator codes. A capital letter is used to indicate the selected function.

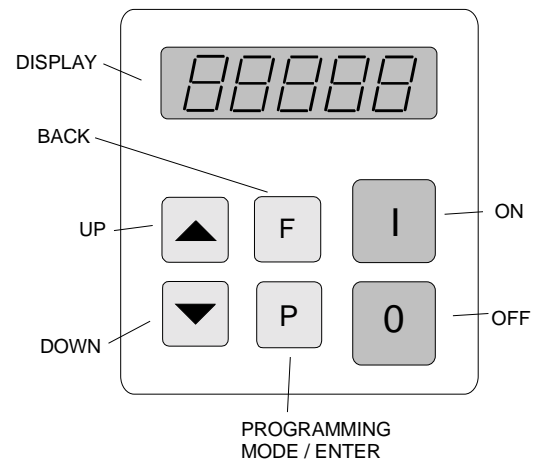

The display value can be increased or decreased by units, or tenths of units, by a short press of the cursor buttons. Holding the buttons down will cause the display to change in units of ten.

#### 6.1.1 Adjustment

To prevent accidental or unauthorized adjustment the adjustment parameters, in the user menus, are protected. A code must be entered to open the user menus. There are different pass codes for each function group.

**Setting adjustments are automatically saved upon leaving the programming mode or if no button is pressed for a period of 100 seconds.**

]

### 6.2 Adjustment Procedure

All setting routines are commenced by pressing the programming button “P”. The following diagram should clarify the sequence in which keys are pressed:-

**Example**

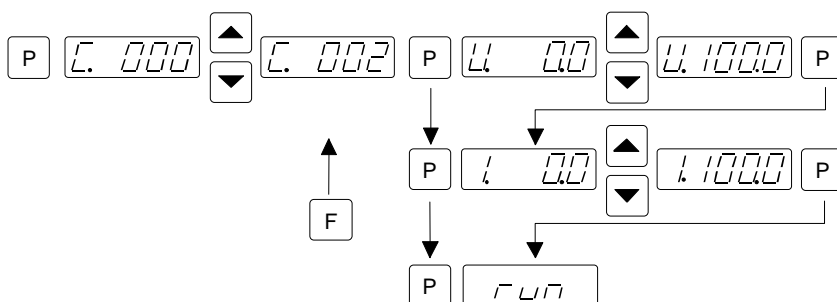



1. Press the “P” key.
2. Select the code number with the cursor keys.
3. Press the “P” key. This displays the first menu point. The required menu point can be found by repeatedly pressing the “P” key (scrolling).
4. The value in the menu point can be changed with the cursor keys..
5. Scroll to the next menu point or to the end of the menu, which returns the display to the set point value, by pressing the “P” key. To exit the menu and return back to the normal display, quickly, depress the “P” key for 5 seconds.
6. To return back to the previous position in the menu, press the “F” key

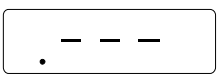

### 6.3 Display Messages

'run' is shown in the LED display during normal running mode.

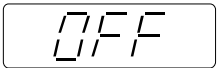
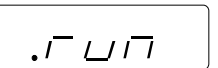
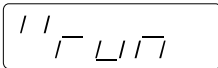
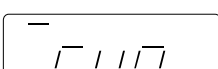
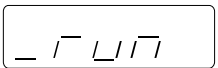
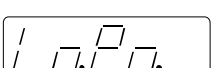
In the programming mode an abbreviation for the corresponding parameter (see setting up instructions) and the setting values, are displayed. Setting changes are stored upon leaving the programming mode or after a pause of 100 seconds.

	Initialisation Phase. When the supply voltage is connected (Left decimal point blinks)
	Normal Operation
	Unit is not enabled
	Left decimal point is present. Current regulation is active. The maximum current of the unit or the regulated current setpoint value has been reached.
	The two upper vertical segments of the first digit illuminate. Peak value limiter. This is caused by a fault condition on either the load or by the externally generated effective value, feedback signal. The load impedance is too low, for example, or the effective value is too high.
	The upper horizontal segment of the first digit illuminates. Maximum control limit of the controller has been reached. The unit has no more regulation range available and so the output voltage is near to the supply voltage.
	Lower horizontal of the first digit illuminates. Maximum power limit has been reached
	Under Voltage, input voltage to too low.

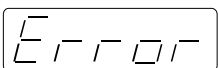
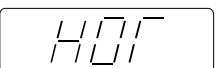
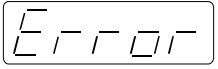
### 6.4 Error Messages

		Overtemperature of the power semi-conductors, output is inhibited. Use `C009` to reset
		Overvoltage, input voltage too high, output is inhibited. Use `C009` to reset

**Error messages must be reset in menu `C009`**

## 7.0 Settings

The following table contains all the available key settable parameters.

The unit is supplied with factory settings that can be recalled from access code "C210" under FAC.

User codes can be saved under code "C143" and then recalled with code "C210" under USPA.

**Table 1**

Parameter:		Code	Factory Default	Menu Code
<b>Setpoint – when internal setpoint is selected only!</b>				
• Voltage Setpoint	0...100 %	U.	0 %	002
• Current Setpoint	0...100 %	I.	0 %	002
•				
<b>Configuration</b>				
• External Setpoint OFF	0 / 1	E.S.O	0	003
• 4...20 mA (only when E.S.P. = I)	0 / 1	4.20	0	003
• External Voltage Setpoint	0 / 1	E.F.U.	0	003
• External Current Setpoint	0 / 1	E.F.I.	0	003
<b>Parameter</b>				
• Minimum Output Voltage (without setpoint)	0...100 %	U.	0 %	020
• Minimum Output Current (without setpoint)	0...100 %	I.	0 %	020
• Maximum Output Voltage (Limit)	50...100 %	<u>u</u>	100 %	020
• Maximum Output Current (Limit)	50...100 %	<u>i</u>	100 %	020
Voltage Regulator – P Characteristic	1...100	P.U.	20	020
Current Regulator - P Characteristic	1...100	P.I.	15	020
Soft Start (ramp)	0...10 Sek.	/.	0,1	020
Soft Stop (ramp)	0...10 Sek.	\	0,1	020
<b>Interface</b>				
Serial Interface ON	0 / 1	S.I.F.	0	017
<b>Service</b>				
Save User Parameter		PUSH		143
Restore Factory Default Settings		FAC.		210
• Display software version				001

**8.0 Setting up instructions**

**8.1 Internal setpoint**

Code 002

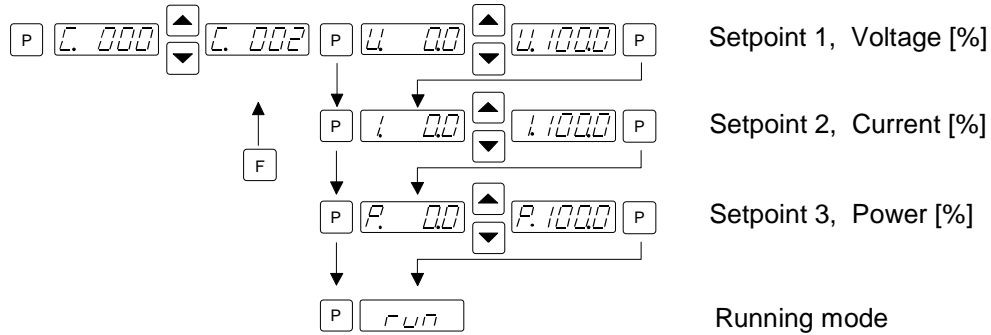

**8.2 Unit configuration**

Code 003

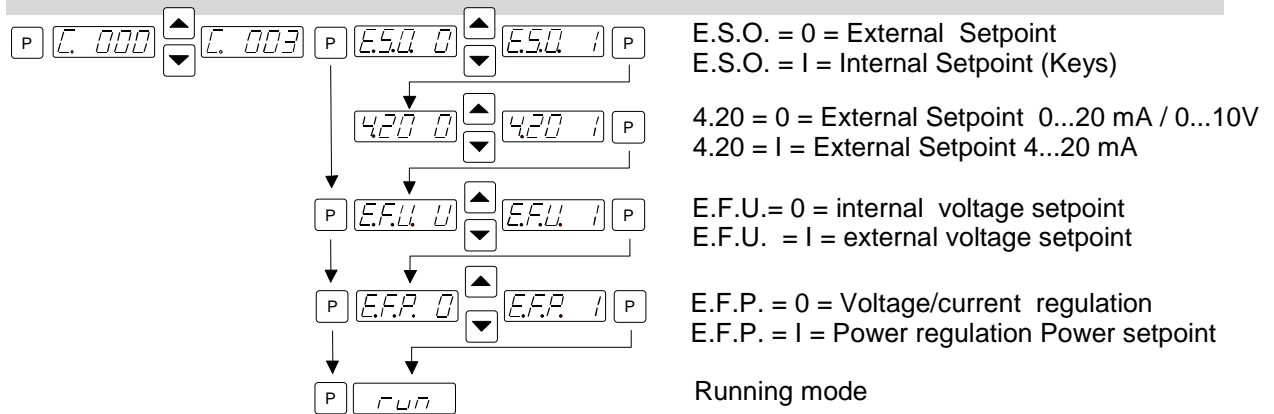

**8.3 Settings**

Code 020

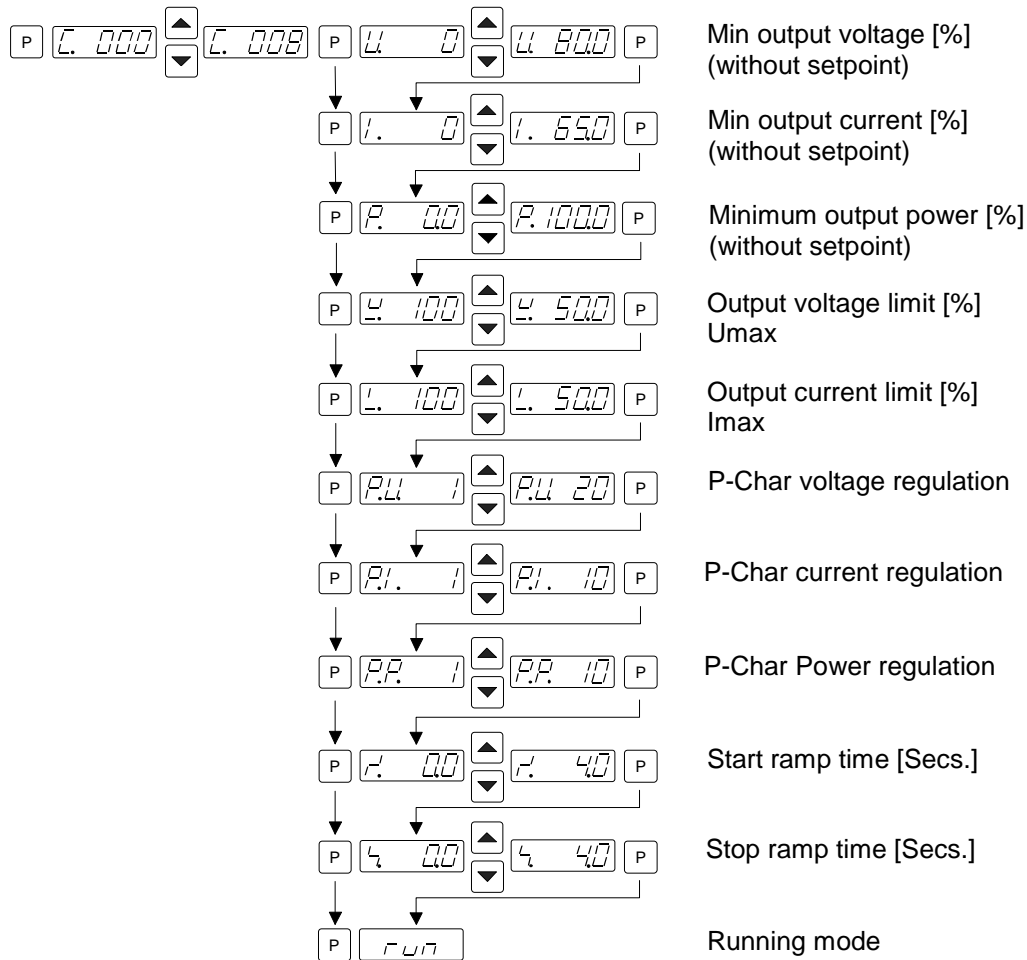

**8.4 Select Interface Protocol**

Code 017 Interface protocol (Option)

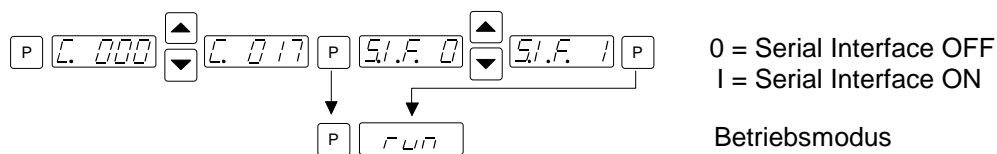

**8.5 Save current settings**

Code 143

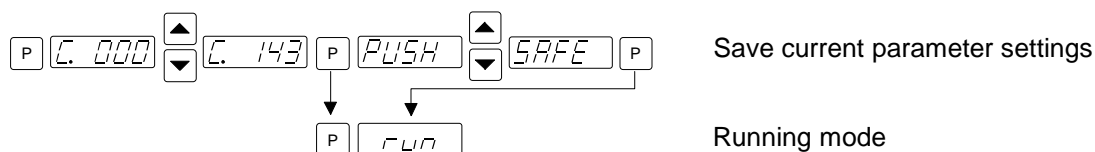

**8.6 Restore Parameter Settings**

Code 210

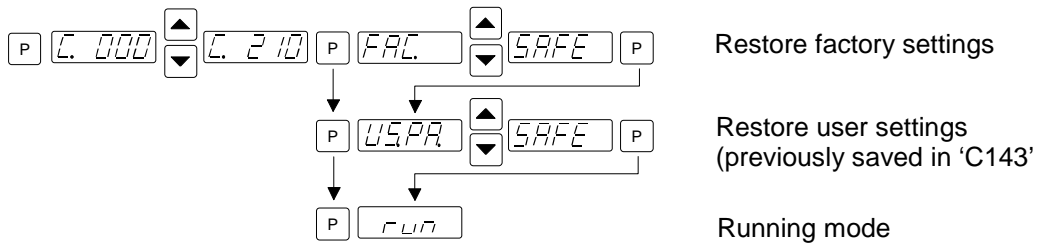

**8.7 Hide parameter menus**

Code 117

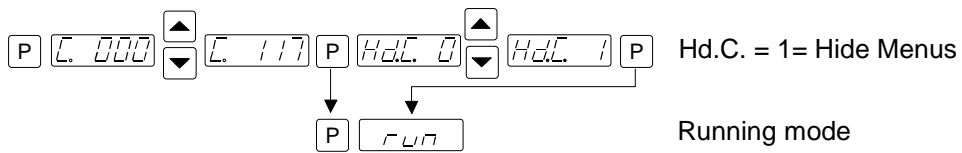

## 9.0 Profibus-DP

### 9.1 Operation with Interface

The interface provides communication with the control unit 3 data words (each using 16 bits) The three 16 bit words are sent and feedback received for each bus cycle. The following settings can be sent to the controller.

Voltage Setpoint (16 bit)	Word 1
Current Setpoint (16 bit)	Word 2
Control Command ON/OFF	Word 3

Feedback from control unit

Actual Voltage (16 bit)	Word 1
Actual Current (16 bit)	Word 2
Status and Fault Warning	Word 3

**Important! Data consistency is required to operate with Profibus Master**

**For example, Data consistency is defined in a Siemens S7 PLC with SFC14 and SFC15.**

#### Note

Units are factory set for analogue operation, parameter SIF in Menu C017 must be set to `1` for bus operation.

### 9.2 Technical Data for Profibus Interface

Bus Power Supply	24 V, DC (20..30 V), 200 mA
Bus connector for Panel mounting version	DB 9
Supported baud rates	9.6, 19.2, 93.7, 187.5, 500, 1.5 Mbaud
Communication	Data consistency
Protocol	DP

### 9.3 GSD File

The following GSD file is required for Profibus interfacing

GSD File Name	REOY6661.GSD
---------------	--------------

The GSD file is supplied on 3.5" Floppy disk with each unit or alternatively, visit [www.reo.de](http://www.reo.de) to download the file from the REO website

## 9.4 Bus Operating Mode

Two fundamental operating modes can be chosen for bus communication.

**Normal Operation:** Control of the thyristor regulator in production, in which case the Setpoint and ON/OFF control signals are transmitted

**Parameter Operation:** Adjustment of the thyristor regulator for the desired operation mode and limits.

In a special mode the parameter and parameter addresses are transmitted and acknowledged.

In parameter operation, the units specific values, such as soft start time, timers and switching etc, are set.

## 9.5 Addressing

The DIP switches in the front panel must be set to give the address of each unit., when the Profibus is used.

The bus address setting is made using the DIP switches in the front panel.  Addresses are in HEX	1	Address bit 0
	2	Address bit 1
	3	Address bit 2
	4	Address bit 3
	5	Address bit 4
	6	Address bit 5
	7	Address bit 6
	8	Reserved

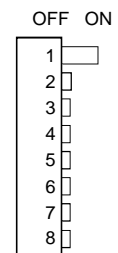

## 10.0 Operation with Interbus S

No addressing is necessary for Interbus-S interface.

Unit I/D code = 33 Hex

**11.0 Programming for Bus operation**

In normal operation the set points for output voltage and current limit and the digital control signals, such as enable are set across the interface. The actual voltage/current values and unit status (ready or fault) are fed back.

All data words are within the range 0...FFFF H

The following communication words are given in bit form

**11.1.1 Send to Controller**

H-Byte								L-Byte								<b>Word 1</b> Voltage Setpoint, 16-Bit, 100 % = FFFF H		
15	14	13	12	11	10	9	8	7	6	5	4	3	2	1	0			
H-Byte								L-Byte								<b>Word 2</b> Current Setpoint, 16 Bit, 100 % = FFFF H		
15	14	13	12	11	10	9	8	7	6	5	4	3	2	1	0			
H-Byte								L-Byte								<b>Word 3</b> Control word Bit = `1` = Function ON All unused bits MUST be set to `0`		
Mode bit	0	0	0	0	0	0	0	0	0	0	0	0	0	0	0		Enable	Switch ON
	0	0	0	0	0	0	0	0	0	0	0	0	0	0	0		0	0
	Control Information (unit specific)																	

0 = Normal operation  
1 = Parameter operation

Enable - bit

**11.1.2 Reply from Controller**

H-Byte								L-Byte								<b>Word 1</b> Actual voltage 16 Bit, 100 % = 8000 H	
15	14	13	12	11	10	9	8	7	6	5	4	3	2	1	0		
H-Byte								L-Byte								<b>Word 2</b> Actual current 16 Bit, 100 % = 8000 H	
15	14	13	12	11	10	9	8	7	6	5	4	3	2	1	0		
H-Byte								L-Byte								<b>Word 3</b> Status - Word X = Not defined Bit = `1` = Funktion ON	
Fault – Code								×	×	×	Enable	×	×	×	×		Status information
								Unit specific									
00	Unit not repoding							Enable-Bit Acknowledge									
70 (H)	Over temperature																
58 (H)	Over load																
A5 (H)	Unit Ready																
C0 (H)	Acknowledge Parameter mode																

Only the unit status is received.

## 11.2 Parameter Operation

In parameter operation, the specific unit parameters can be monitored and adjusted.

A `write` enable must be transmitted before parameters can be altered. On closed the `write` enable must be cancelled.

A `read` request must be sent before data can be read.

Word 3 in the acknowledge is always `CODE H`. This indicates that the controller is in parameter mode.

### 11.2.1 Creating parameter address's and values

In parameter operation the most significant bit (msb) in Word 1 is defined as a read or write bit (R/W), where 1 = write and 0 = read, this should be accompanied by the corresponding parameter address.

The mode bit (msb in Word 3) is used to select normal or parameter operation, 0 = Normal or 1 = Parameter operation.

<b>Word 1:</b>	<b>R/W – Bit + Address</b>	<b>e.g. 8000 H + 1009 H =&gt; 9009 H</b>
<b>Word 2:</b>	<b>Value of the parameters</b>	<b>e.g. 7FFF H</b>
<b>Word 3:</b>	<b>Mode bit = 1 + control bits</b>	<b>e.g. 8000 H + 0004 H =&gt; 9004 H</b>

For bit orientated parameters, ONLY those bits relating to the required function may be changed, all other bits MUST remain unaltered, otherwise factory specific settings may be inadvertently altered!

#### Procedure for changing bit parameters:-

1. Select parameter value
2. Change only the required bit (s) in the selected parameter
3. Send `write` enable
4. Send the changed parameters back to the same address
5. Close the `write` enable

**11.2.2 Send Write Enable**

H-Byte								L-Byte								Word 1
<b>C0</b>								<b>DE</b>								Write Enable Address =C0DE H
H-Byte								L-Byte								Word 2
<b>B5</b>								<b>E7</b>								Write Enable =B5E7 H
H-Byte								L-Byte								Word 3
15	14	13	12	11	10	9	8	7	6	5	4	3	2	1	0	Control - Word + 8000 H
<b>1 Mode bit</b>																Mode bit must be set to `1`!!
																All unused bits must be set to `0`
																Bit = `1` = Function ON
Control Information unit specific																

**11.2.3 Receive, Acknowledge Write Enable**

H-Byte								L-Byte								Word 1
<b>C0</b>								<b>DE</b>								C0DE H
H-Byte								L-Byte								Word 2
<b>B5</b>								<b>E7</b>								B5E7 H
H-Byte								L-Byte								Word 3
<b>C0</b>								<b>DE</b>								<b>C0DE H</b>

The parameters can be send after receipt of the acknowledge

**11.2.4 Send Parameter**

H-Byte								L-Byte								<b>Word 1</b>
15	14	13	12	11	10	9	8	7	6	5	4	3	2	1	0	
<b>R / W</b>	<i>Parameter address</i>															
	H-Byte								L-Byte							
<b>XX</b>								<b>XX</b>								Parameter value (16-Bit) = 0...FFFF H
H-Byte								L-Byte								Word 3
15	14	13	12	11	10	9	8	7	6	5	4	3	2	1	0	Control - Word + 8000H
<b>1 Mode bit</b>																Mode must be set to `1`!
																All unused bits must be set to `0`
																Bit = `1` = Function ON
Control Information (unit specific)																

## 12.0 Parameter Table

Non listed addresses cannot be altered!

Setting	Setting Range	Display-Code	Factory Default	Menu Code	Parameter Address HEX (.bit)	Value range HEX
• Maximum regulation limit ( $U_{max}$ )	50...100 %	<u>u</u>	100 %	020	1009	8000...FFFF H
• Maximum regulation limit ( $I_{max}$ )	50...100 %	<u>i</u>	100 %	020	1008	8000...FFFF H
• Soft start	0...10 sec	/.	0,1 Sek.	020	1013	0...FFFF H
• Soft stop	0...10 sec.	\.	0,1 Sek.	020	1012	0...FFFF H
• External setpoint	0 / 1	E.S.O.	0	003	1800.0	0 / 1
• Setpoint 0(4)...20 mA	0 / 1	4.20	0	003	1800.1	0 / 1
• Enable invert	0 / 1	-En.	0	003	1801.1	0 / 1
• Proportional characteristic Voltage regulation	0...100	P.U.	20	020	100F	28F...FFFF H
• Proportional characteristic Current regulation	0...100	P.I.	15	020	100D	28F...FFFF H
• Proportional characteristic Power regulation	0...100	P.P.	15	020	100E	28F...FFFF H
<b>Interface (only if option provided)</b>						
• Interface ON/OFF	0 / 1	S.I.F.	I	017	1801.8	0 / 1
<b>Service</b>						
• ERROR Reset	Reset	CLr.Er.		009	1400	C009 H
• Hide programming menus	0 / 1	Hd.C.		117	1800.4	0 / 1
• User parameter menu choose No. 0...3	0...3	U.S.I.	0	143		
• Save user settings		PUSH.		143		
• Recall factory settings		FAC.		210		
• User parameter menu choose No 0...3	0...3	U.S.I.	0	210		
• Recall user settings		US.PA.		210		

### 13.0 Example of bus communication

Variable values are shown in *italics*

#### 13.1 Normal mode

Set setpoint to 70 %

Send Setpoint	Word	Code	Send	Code	Received
1		B332 H	Setpoint = 70 %	---	---
2					
3		0005 H	Enable ON	A5xx H	Ready

Enable ON, Stop controller (with enable)

Send Setpoint	Word	Code	Send	Code	Received
1		B332 H	Setpoint = 70 %	---	---
2					
3		0001 H	Enable OFF	A5xx H	Ready

Switch OFF

Send Setpoint	Word	Code	Send	Code	Received
1		B332 H	Setpoint = 70 %	---	---
2					
3		0000 H	Switch OFF	A5xx H	Ready

#### 13.2 Parameter Operation

e.g. Set Soft Start time to 2 seconds

Open Write Enable	Word	Code	Send	Code	Received
1		C0DE H	Enable Address	C0DE H	Acknowledge
2		B5E7 H	Write enable value	B5E7 H	Acknowledge
3		8000 H + control bit	Set mode bit = 1	C0DE H	Acknowledge

Write Parameter	Word	Code	Send	Code	Received
1		9013 H	Parameter address Soft start + R / W - Bit	9013 H	Acknowledge
2		3333 H	Soft start 2 Sec	3333 H	Acknowledge 2 Sec
3		8000 H + control bit	Set mode bit = 1	C0DE H	Acknowledge

Close write enable	Word	Code	Send	Code	Received
1		C0DE H	Enable Address	C0DE H	Acknowledge
2		0000 H	Write enable value	0000 H	Acknowledge
3		8000 H + control bit	Set mode bit = 1	C0DE H	Acknowledge

Parameter Read Only

Read	Word	Code	Send	Inhalt	Received
1		1013 H	Parameter address Soft start	1013 H	Acknowledge
2		0000 H	Read parameter	8000 H	Parameter value ( => 5 secs)
3		8000 H + control bit	Set mode bit = 1	C0DE H	Acknowledge parameter mode

Example of bit parameter change

Read Parameter	Word	Code	Send	Code	Receive
	1	1800 H	Parameter address	1800 H	Acknowledge
	2	0000 H	Parameter read	0000 H	Parameter value
	3	8000 H + control bits	Set mode bit = 1	C0DE H	Acknowledge parameter mode

Change bit in selected parameter value  
(e.g. Set bit 1 at address 1800 H to 1 = 4...20 mA).

Write Enable	Word	Code	Send	Code	Receive
	1	C0DE H	Write enable address	C0DE H	Acknowledge
	2	B5E7 H	Write enable value	B5E7 H	Acknowledge
	3	8000 H + control bits	Set mode bit = 1	C0DE H	Acknowledge

Write Parameter	1	9800 H	Parameter address	9800 H	Acknowledge
	2	0002 H	New parameter	0002 H	Acknowledge
	3	8000 H + control bits	Set mode bit = 1	C0DE H	Acknowledge

Close Write enable	Word	Code	Send	Code	Receive
	1	C0DE H	Write enable address	C0DE H	Acknowledge
	2	0000 H	Write enable value	0000 H	Acknowledge
	3	8000 H + control bits	Set mode bit = 1	C0DE H	Acknowledge

### 13.3 RESET Controller

Open Write enable	Word	Code	Send	Code	Receive
	1	C0DE H	Write enable Address	C0DE H	Acknowledge
	2	B5C9 H	Write enable Value	BC97 H	Acknowledge
	3	8000 H + control bits	Set mode bit = 1	C0DE H	Acknowledge

Write parameter	1	9400 H	Parameter address Reset + R / W - Bit	9400 H	Acknowledge
	2	C009 H	RESET.	C009 H	
	3	8000 H + control bits	Set mode bit = 1	C0DE H	

Allow approximately 0.5 secs for RESET

14.0 Controls

14.1 INTERBUS-S Interface

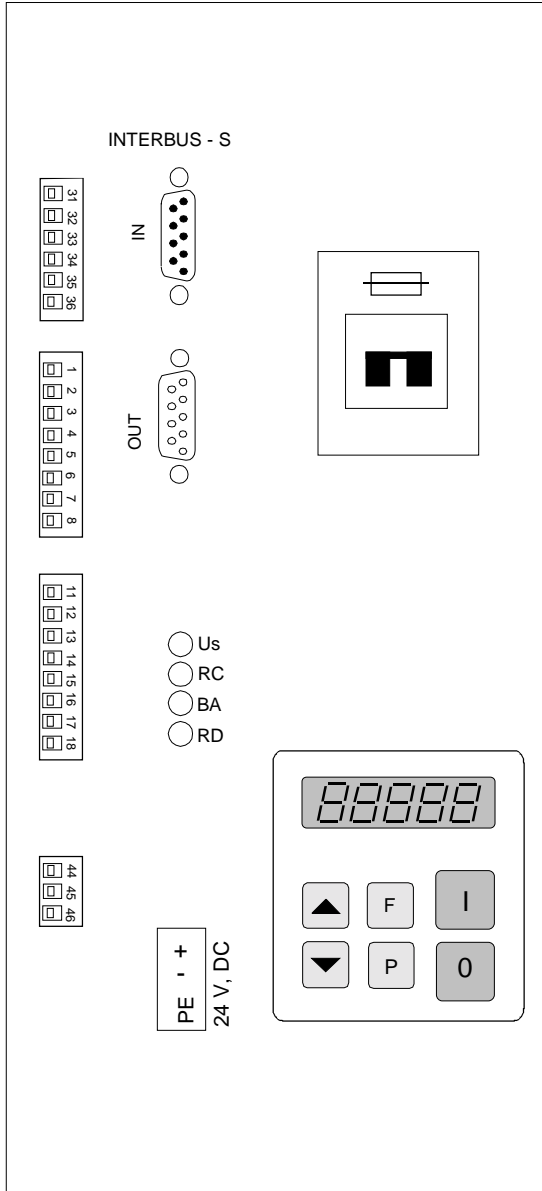

Interface indications

- |    |                    |
|----|--------------------|
| Us | Supply voltage     |
| RC | Remote bus - check |
| BA | Bus active         |
| RD | Remote bus disable |

**14.2 PROFIBUS-DP Interface**

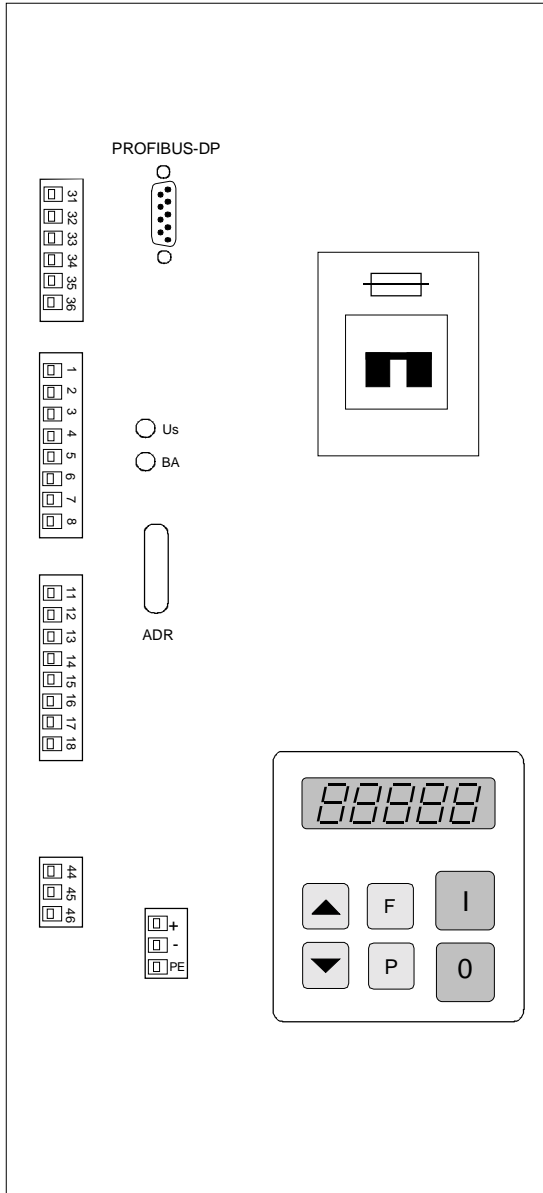

**Address Switch**

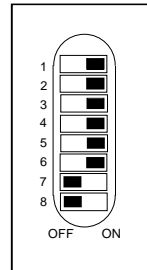

- S3/1 Address bit 0
- S3/2 Address bit 1
- S3/3 Address bit 2
- S3/4 Address bit 3
- S3/5 Address bit 4
- S3/6 Address bit 5
- S3/7 Address bit 6
- S3/8 Reserve

**Interface Indicators**

- Us Supply voltage
- BA Bus active

15.0 Schematic Circuit

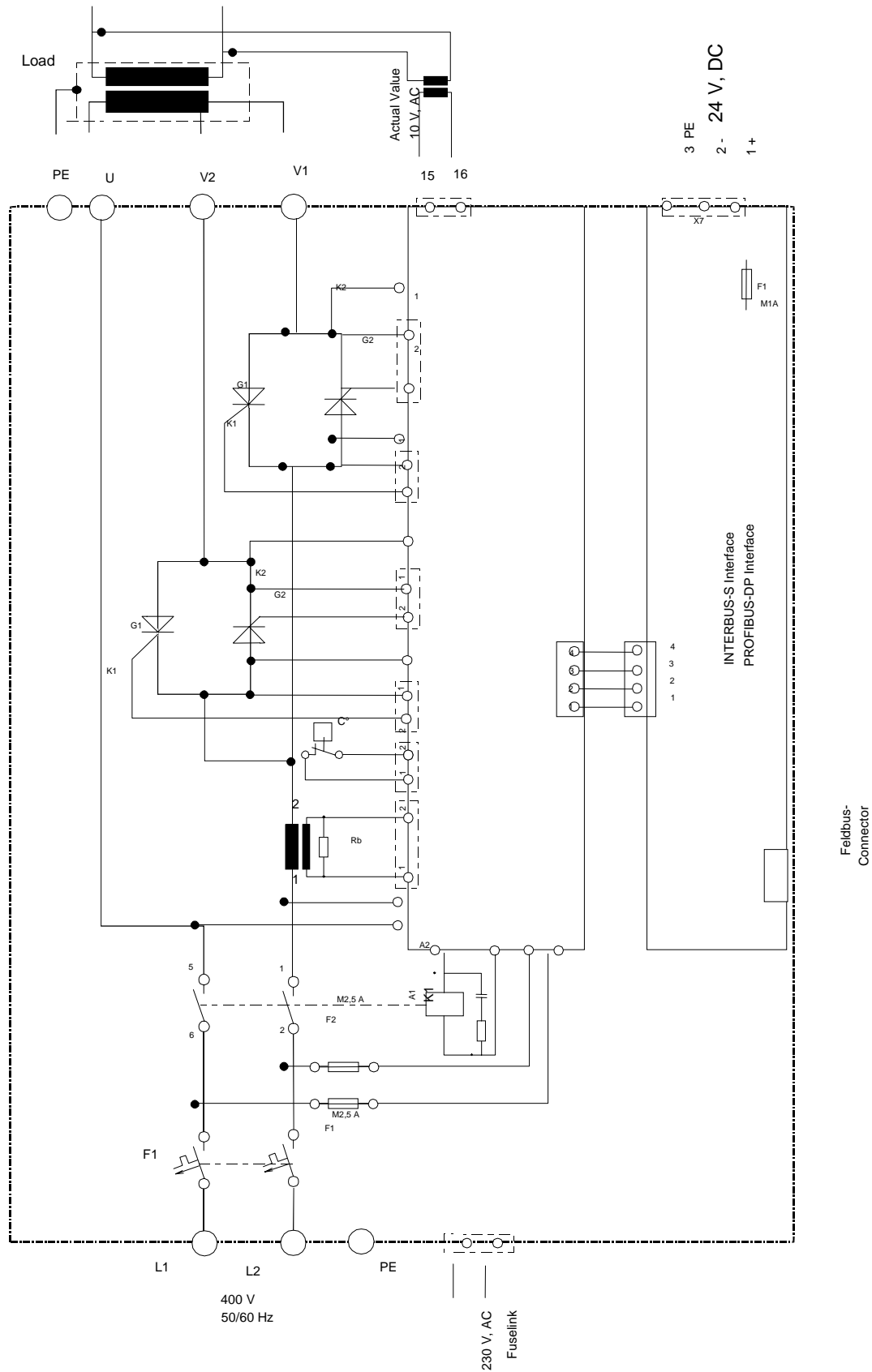

**16.0 Connection Diagram**

Power Connections

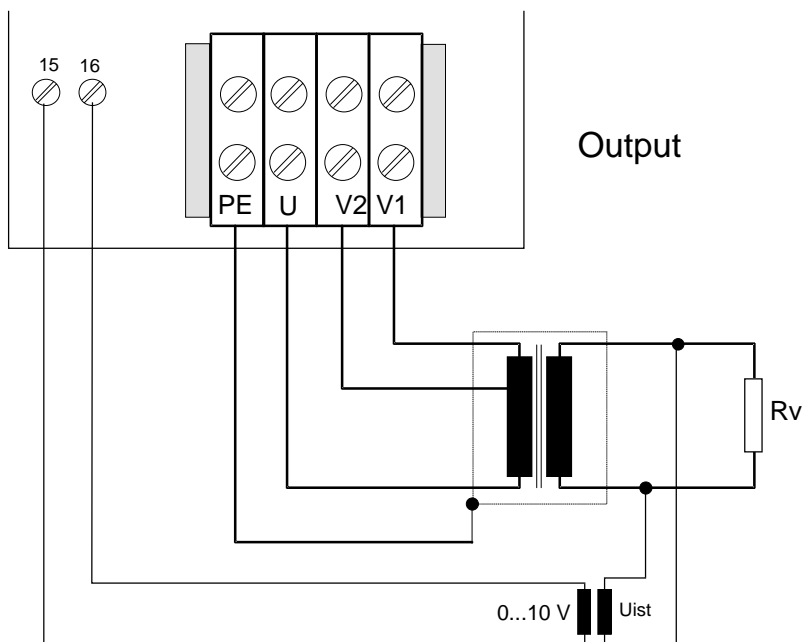
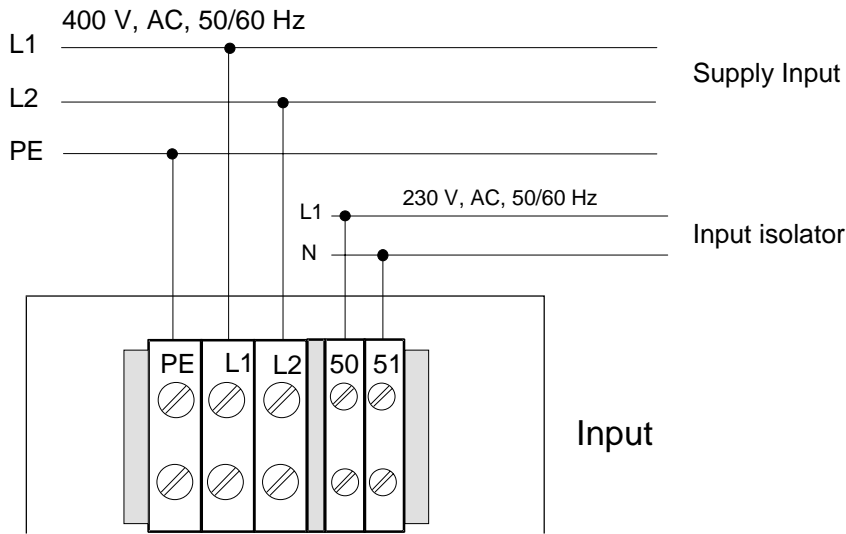

Control Stage Connections

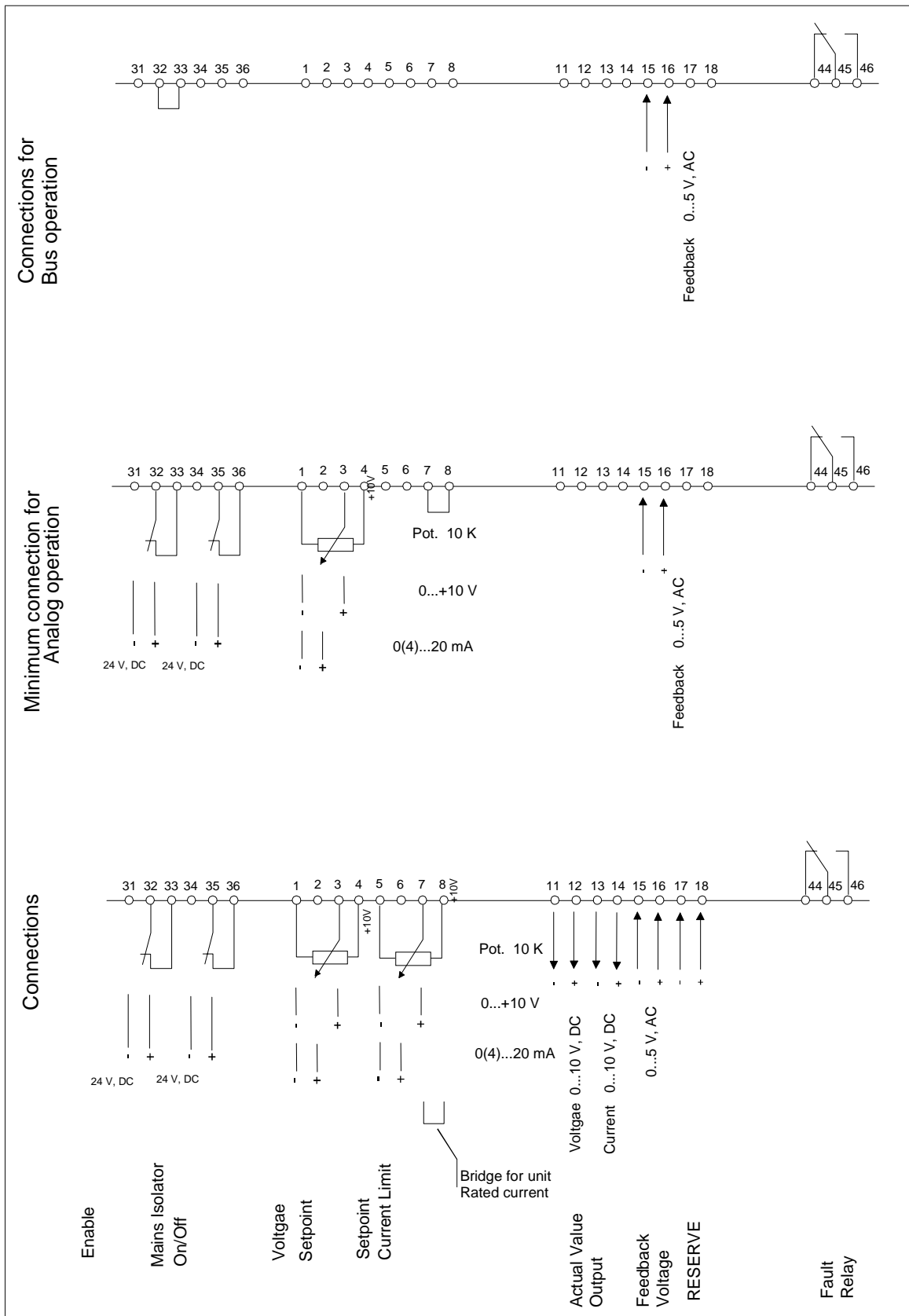

Fieldbus Connections

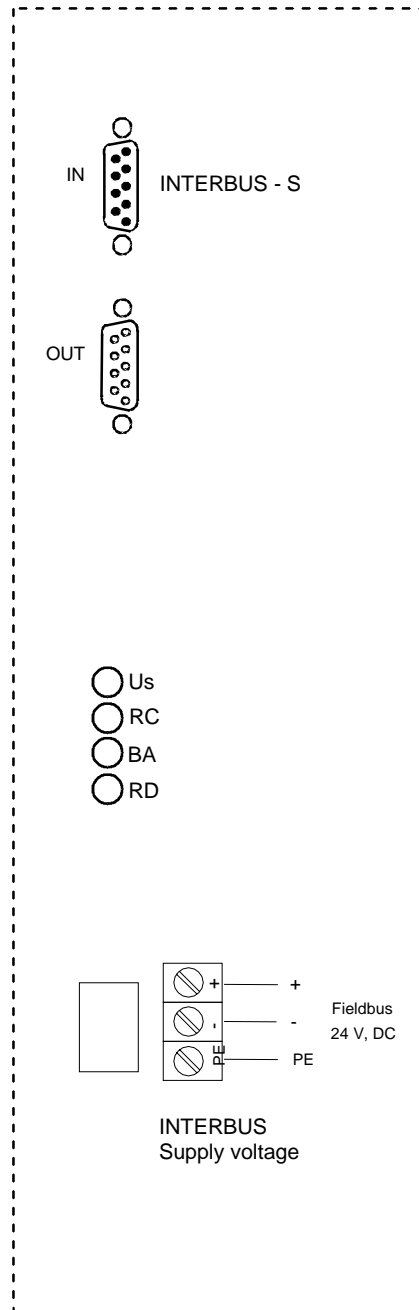
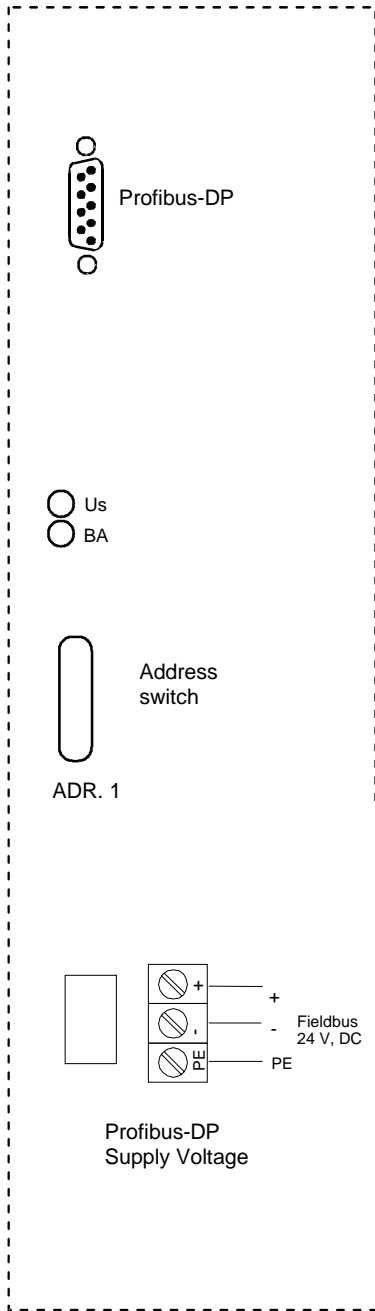

**17.0 Dimensions**

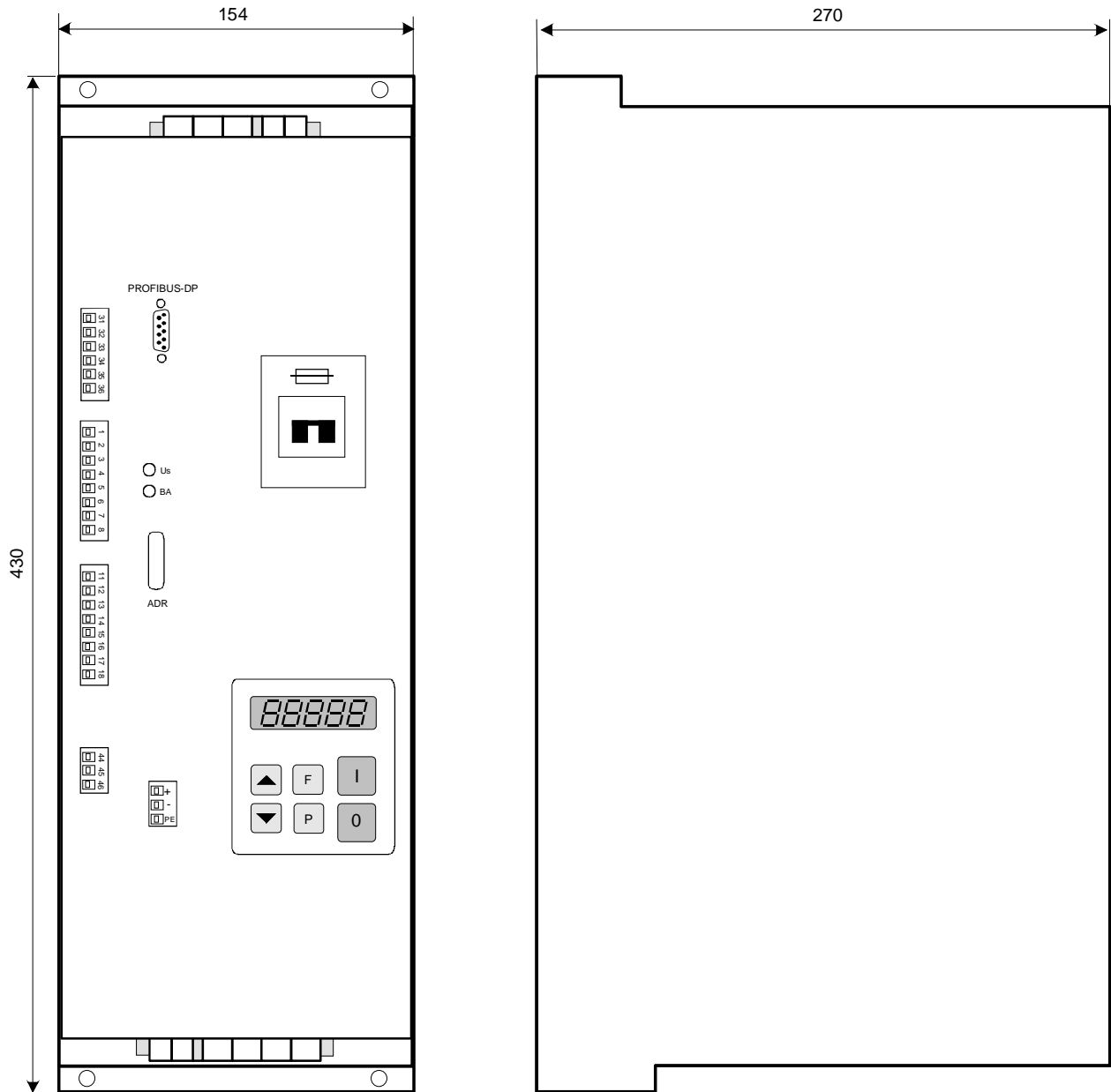

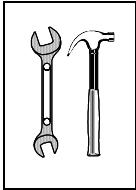
**18.0 Mounting**

The control unit is designed for mounting within a suitably rated control housing

**All control connections should be made with screened cables, with the screen bonded to earth PE**