

Range REOVIB MTS

Thyristor controllers for vibratory feeders

Operating features and application examples

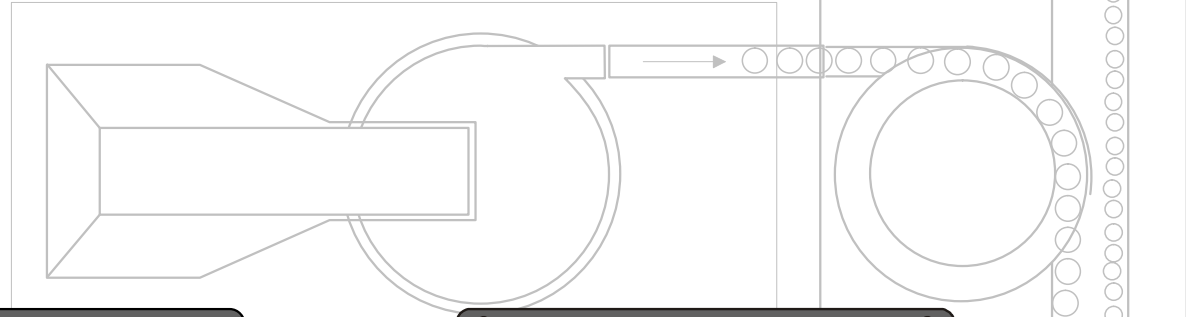
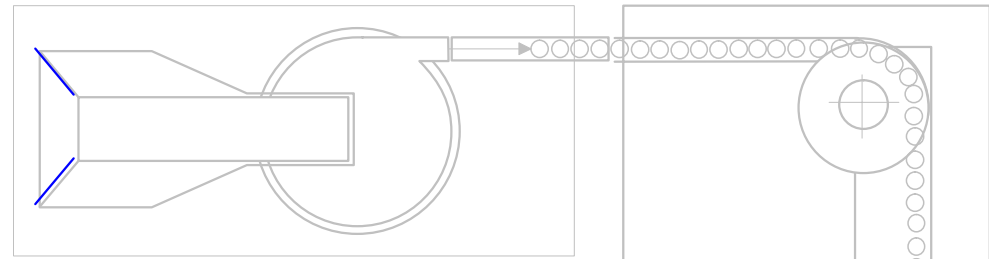
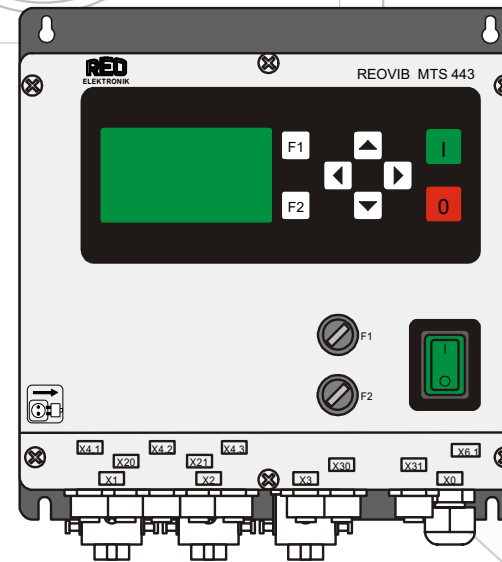
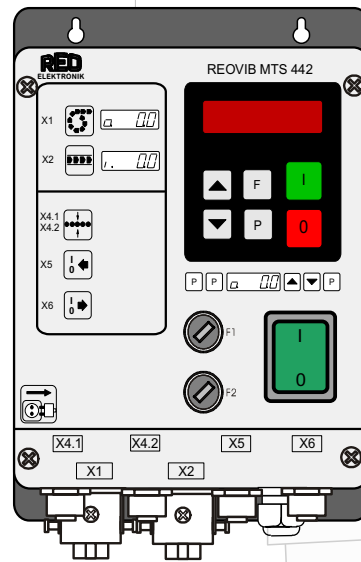
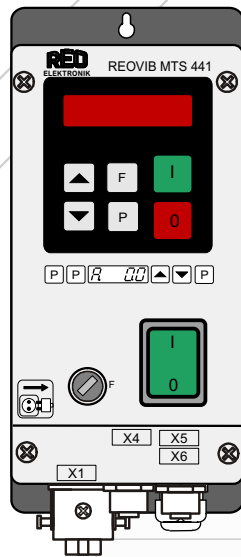
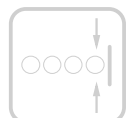
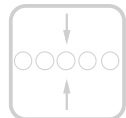

The REOVIB MTS ... range includes one, two or three channel controllers for vibratory feeders. Working on the phase-angle control principle, they include a triac as a power element. Therefore, the vibrating frequency of the feeder can be the same as or double that of the mains frequency. The units are IP 54 rated and they are designed for easy mounting, especially when an aluminium section mounting rail is used. Plug-in connectors for all inputs and outputs allow quick connection and simplify the combination of several units and their their connection to external controls. The digital units are set up using buttons and an LED/LCD display. All settings can be made externally without opening the enclosure. Standardised plug-in connectors for identical functions allow these units to be combined with units from other ranges.

1-Channel controller
MTS 441

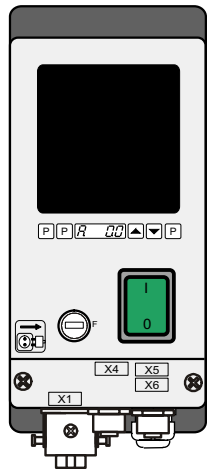

2-Channel controller
MTS 442

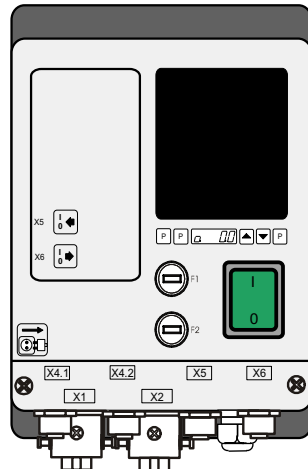

3-Channel controller
MTS 443

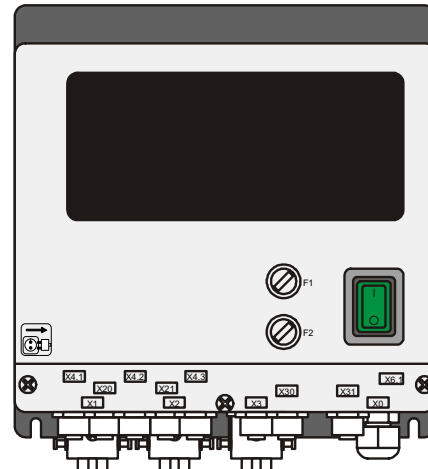

Mountings:
Mounting rail RPG



Add-on units:

Frequency controllers
REOVIB MFS ...

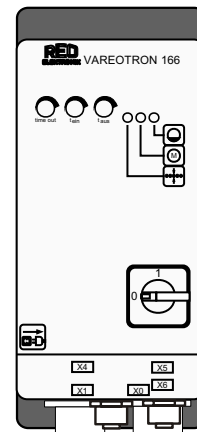
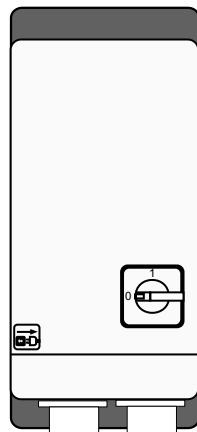
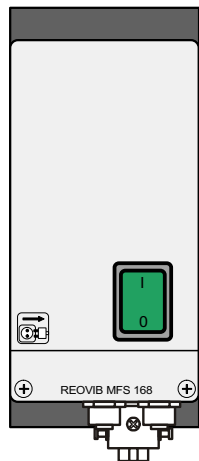

Control unit,
including
motor contactor,
for belt hopper
with 3-phase
or single-phase
motor

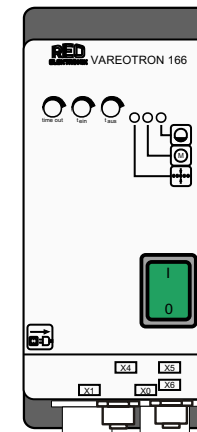

Control unit
for belt hopper with
24 V, DC motor

REOVIB MTS 441

1-Channel controller
for vibratory feeders

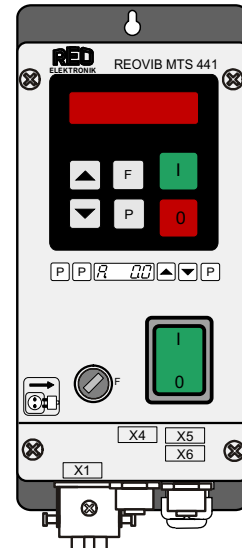

Input
1 AC, L, N, PE
110 V / 240 V

PNP Sensor 24 V, DC

24 V, DC Output - Air jet
(internal connection)

I / O Enable: 24 V, DC or
I / O Status 24 V, DC
Ready Status 24 V, DC (Mains ON)
Time out 24 V, DC
(empty signal)

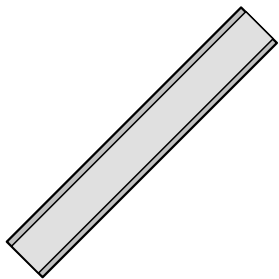

Linear feeder

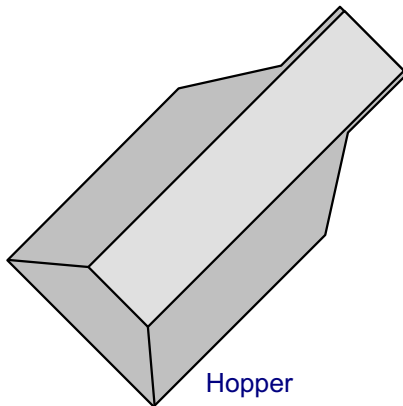

Hopper

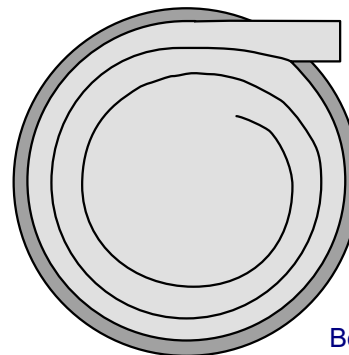

Bowl feeder

Output :
0... 100 V
0... 210 V
0... 6 A max

Vibrating frequency:
50 Hz / 100 Hz

Soft start: Ramp

Track control :
t-on t-off

REOVIB MTS 442

2-Channel controller
for vibratory feeders

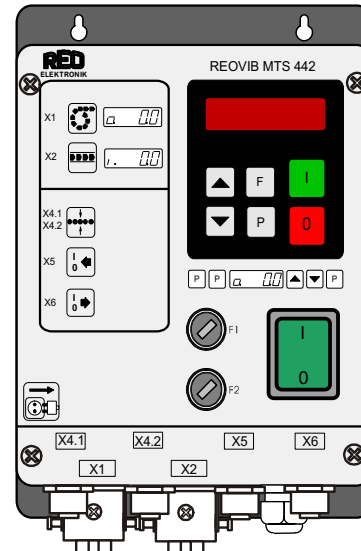

Input
1 AC, L, N, PE
110 V / 240 V

Additional
sensor functions

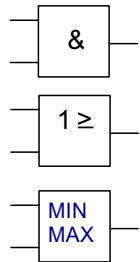

PNP Sensor 24 V, DC

PNP Sensor 24 V, DC

24 V, DC Output - Air jet
(internal connection)

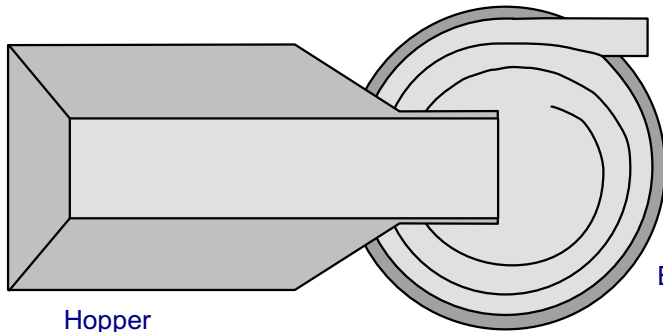

Hopper

Bowl feeder

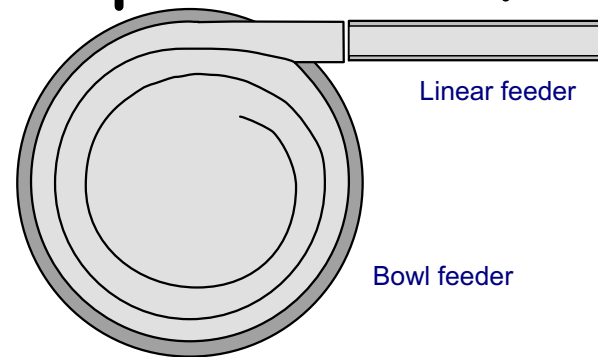

Linear feeder

Bowl feeder

- ← I/O Enable 1 : 24 V, DC or
- ← I/O Enable 2 : 24 V, DC or
- I/O Status 1 : 24 V, DC
- I/O Status : 24 V, DC (Mains ON)
- Ready Status 2 : 24 V, DC
- 💡 Time out 24 V, DC (common) (empty signal)

Output :
0... 100 V
0... 210 V
0... 6 A, 10 A max in total

Vibrating frequency: 50 Hz / 100 Hz

Soft start: Ramp

Track control : t-on t-off

REOVIB MTS 443

3-Channel controller
for vibratory feeders

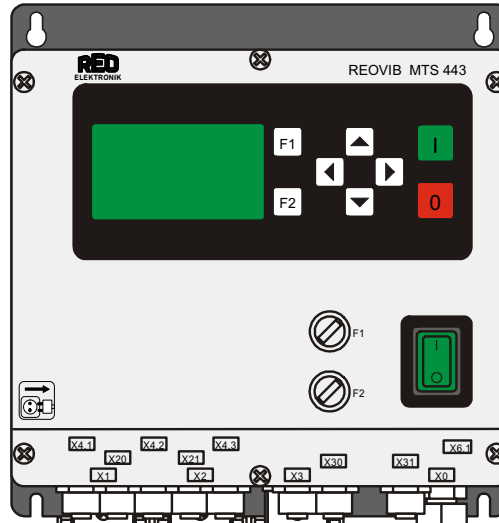

Input
1 AC, L, N, PE
110 V / 240 V

- PNP Sensor 24 V, DC
- PNP Sensor 24 V, DC
- PNP Sensor 24 V, DC
- Valve 1, 24 V output
- Valve 2, 24 V output

- Enable: 24 V, DC or I/O Status 24 V, DC
- Ready Status 24 V, DC (Mains ON)
- Time out 1: 24 V, DC (empty signal)
- Time out 2: 24 V, DC (empty signal)

Additional sensor functions

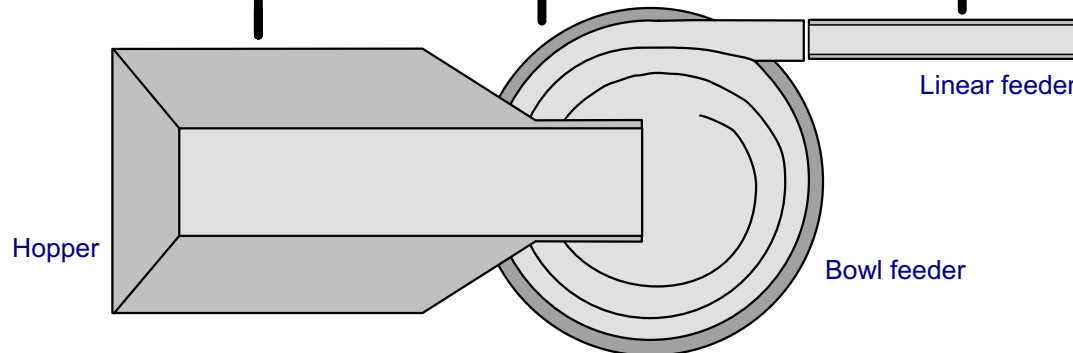
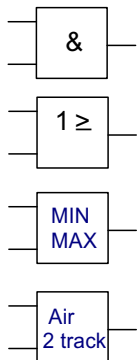

- Output : 0... 100 V
0... 210 V
0... 6 A,
10 A max in total
- Vibrating frequency: 50 Hz / 100 Hz
- Soft start: Ramp
- Track control : t-on t-off

REOVIB MTS 442 for bowl feeder and linear feeder

REOVIB MTS 442
Bowl feeder Channel 1
Linear feeder Channel 2

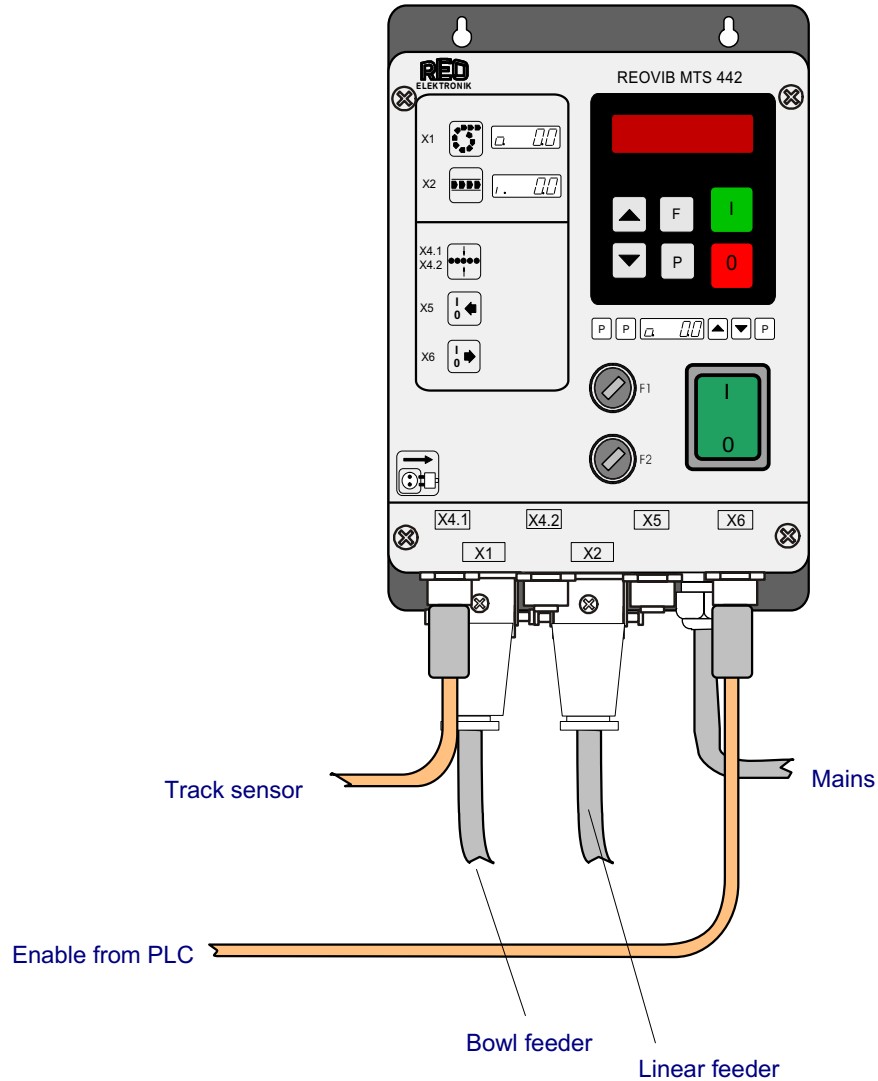
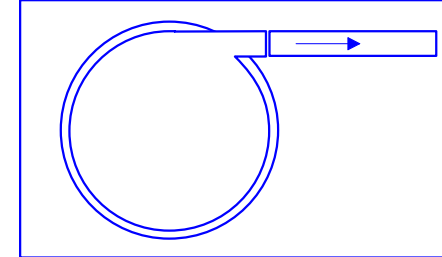

External enable signal:
With an external 24 V DC voltage signal from a PLC, the linear feeder and therefore also the bowl feeder can be enabled or disabled, for example.

Interlock settings of MTS 442:
Menu "C003": Channel 2 disables Channel 1 "i. - o." = 1
Menu "C020": Invert enable "o.-En." = 1
Menu "C021": Invert enable "i.-En." = 0

Without external enable signal to MTS 442:
Menu "C021": Invert enable "i.-En." = 1

REOVIB MTS 442 for bowl feeder and hopper

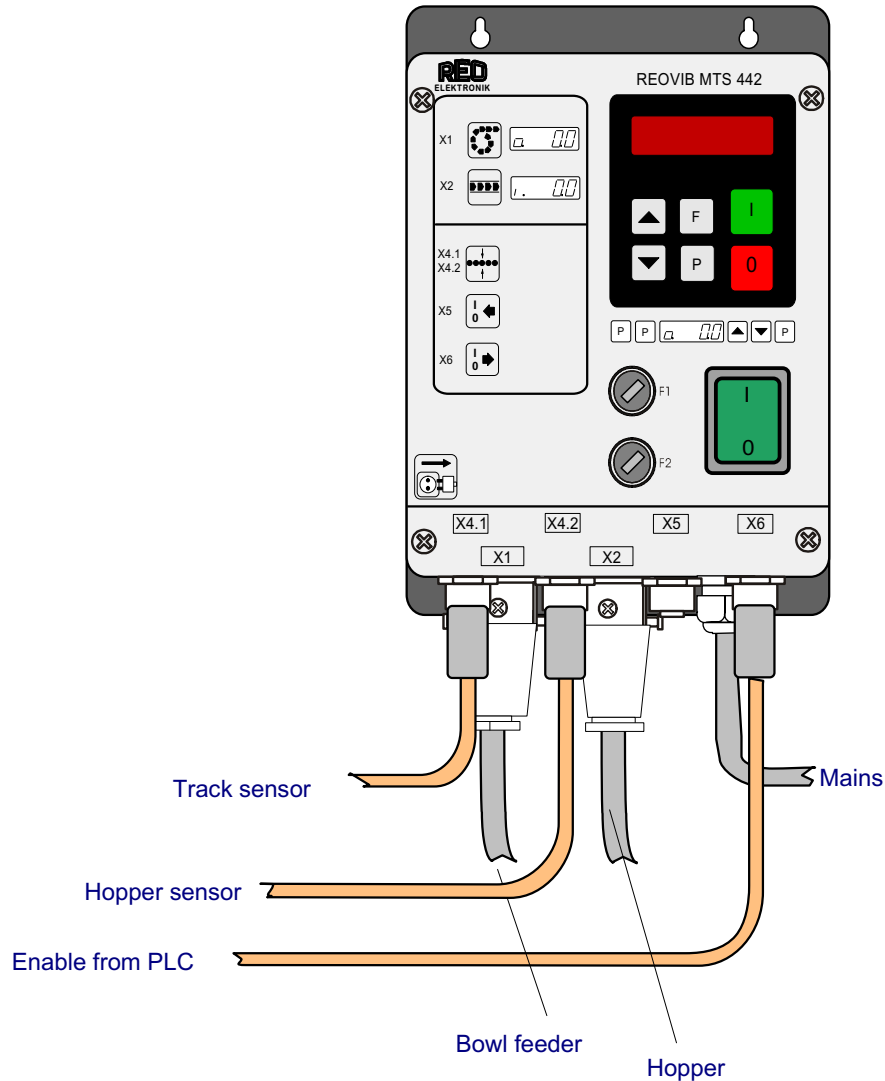

REOVIB MTS 442
Bowl feeder Channel 1
Hopper Channel 2

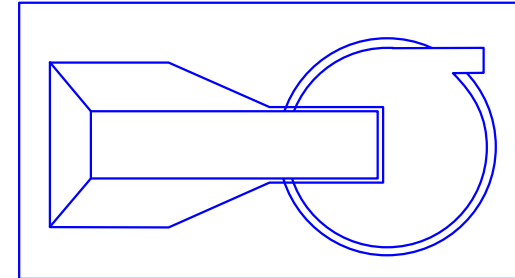

External enable signal:

With an external 24 V DC enable signal from a PLC, the bowl feeder and therefore also the hopper can be enabled or disabled, for example.

Interlock settings of MTS 442:

Menu "C003":	Channel 2 disables Channel 1	"i. - o." = 1
Menu "C020":	Invert enable	"o.-En." = 1
Menu "C021":	Invert enable	"i.-En." = 0

Without external enable signal to MTS 442 :

Menu "C021":	Invert enable	"i.-En." = 1
--------------	---------------	--------------

Triple control of linear feeder, bowl feeder and hopper by combining REOVIB MTS 442 and MTS 441

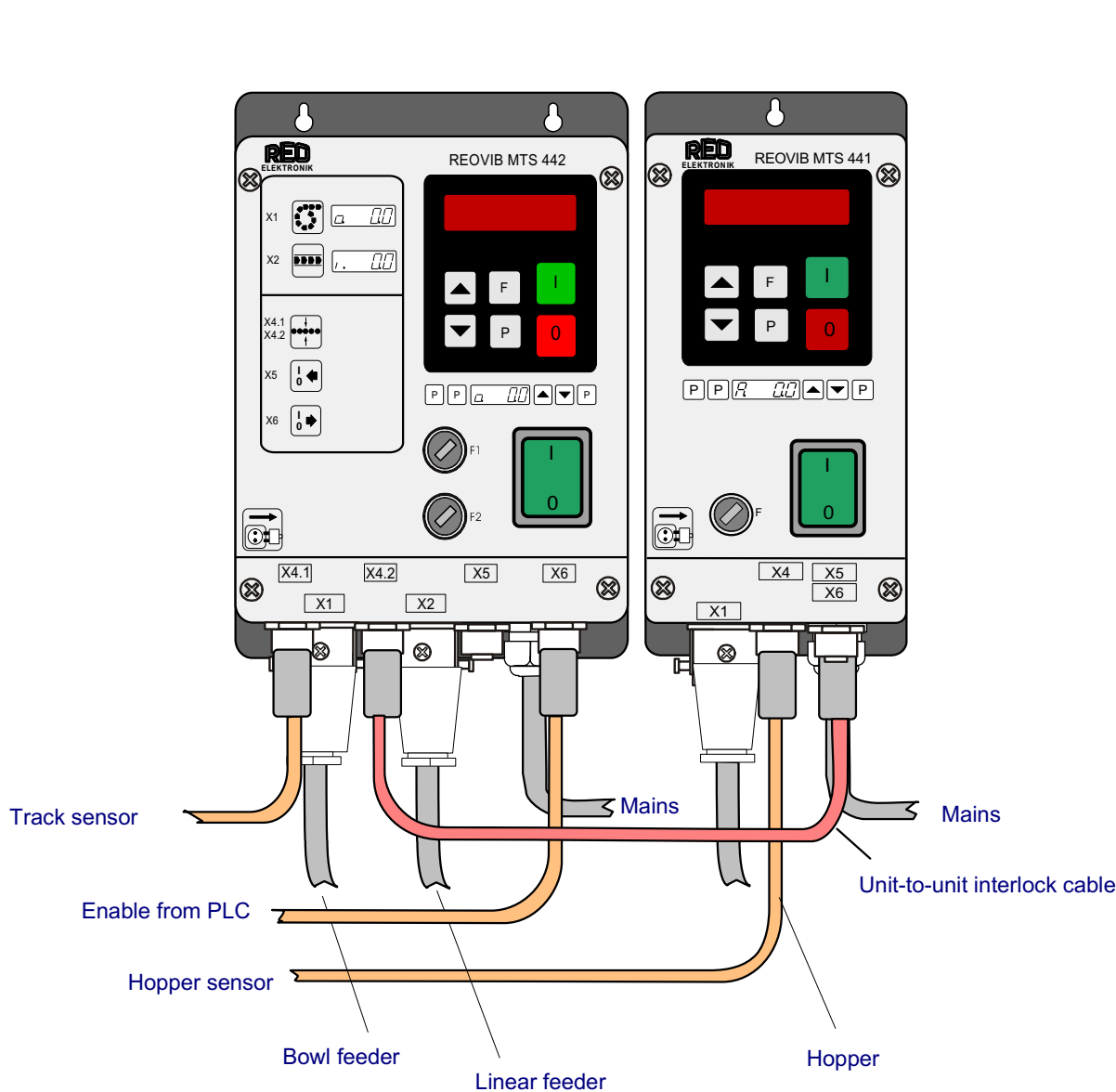

REOVIB MTS 441
Hopper Channel 1

REOVIB MTS 442
Bowl feeder Channel 1
Linear feeder Channel 2

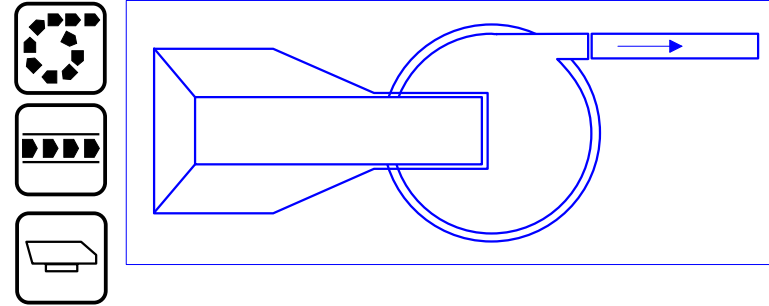

External enable signal:

With an external 24 V, DC enable signal from a PLC, linear feeder and therefore also the upstream controllers can be enabled or disabled, for example.

Interlock settings of MTS 442:

Menu "C003": Channel 2 disables Channel 1	" i, - o. " = I
Menu "C020": Invert enable	" o.-En." = I
Menu "C021": Invert enable	" i.-En." = 0

Interlock settings of MTS 441:

Menu "C020": Invert enable	" o.-En." = I
----------------------------	---------------

Interlocking with hopper control via a connection cable (PIN 3-3, 4-4) from Status MTS 442 (X5) to Enable MTS 441 (X6).

Without external enable signal to MTS 442 :

Menu "C021": Invert enable	" i.-En." = I
----------------------------	---------------

Triple control of linear feeder, bowl feeder and hopper by combining REOVIB MTS 442 and REOVIB MFS 168

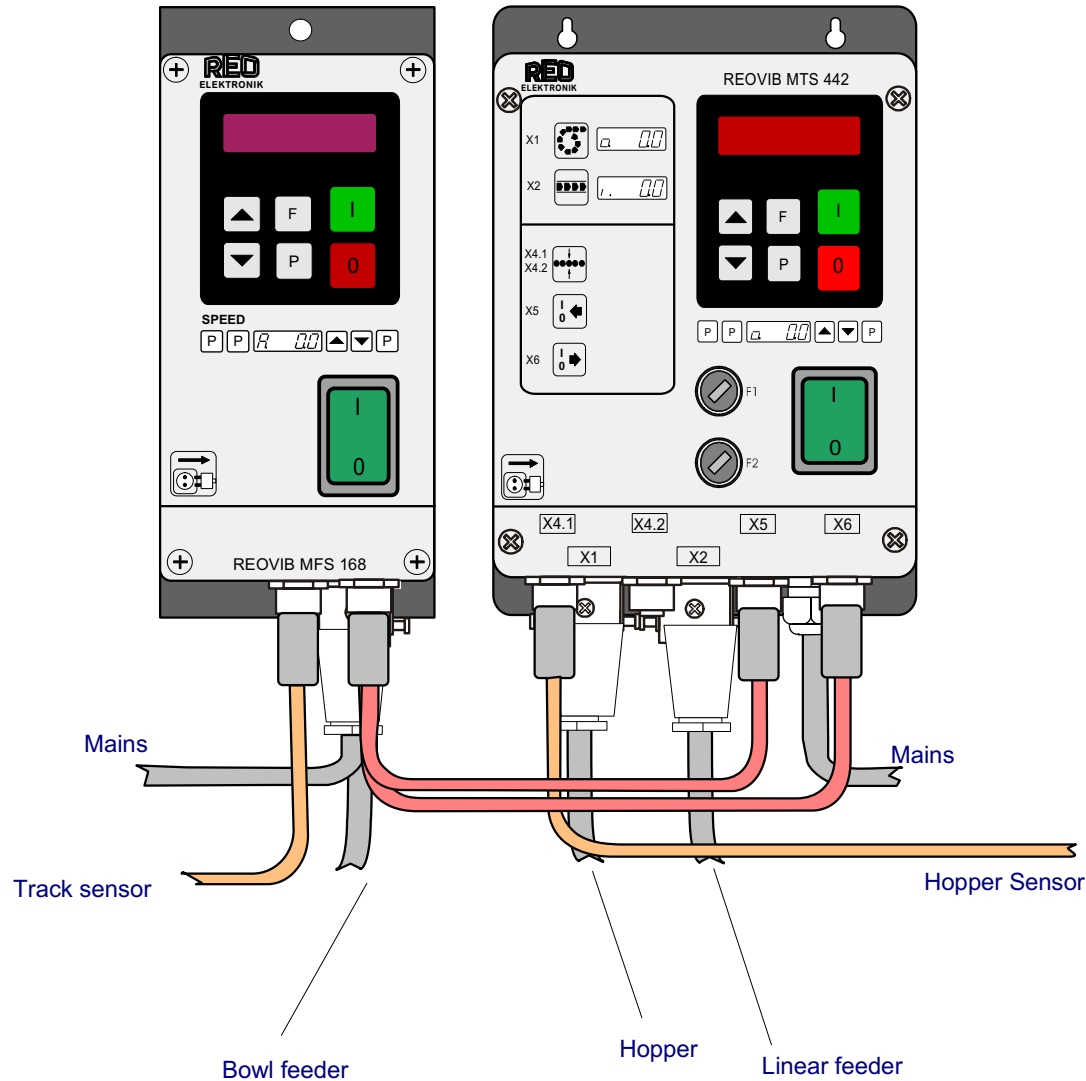

REOVIB MTS 442
Linear feeder Channel 2
Hopper Channel 1

REOVIB MFS 168
Bowl feeder

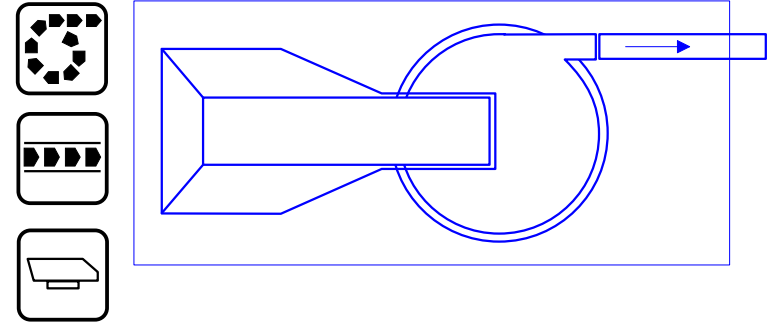

The status of the linear feeder (ON/OFF) disables or enables the bowl feeder. The bowl feeder at "ON" enables the hopper. The bowl feeder and the hopper feeder are controlled via 24 V PNP-sensors.

Triple control of linear feeder, bowl feeder and hopper by combining REOVIB MTS 442 and MTS 440

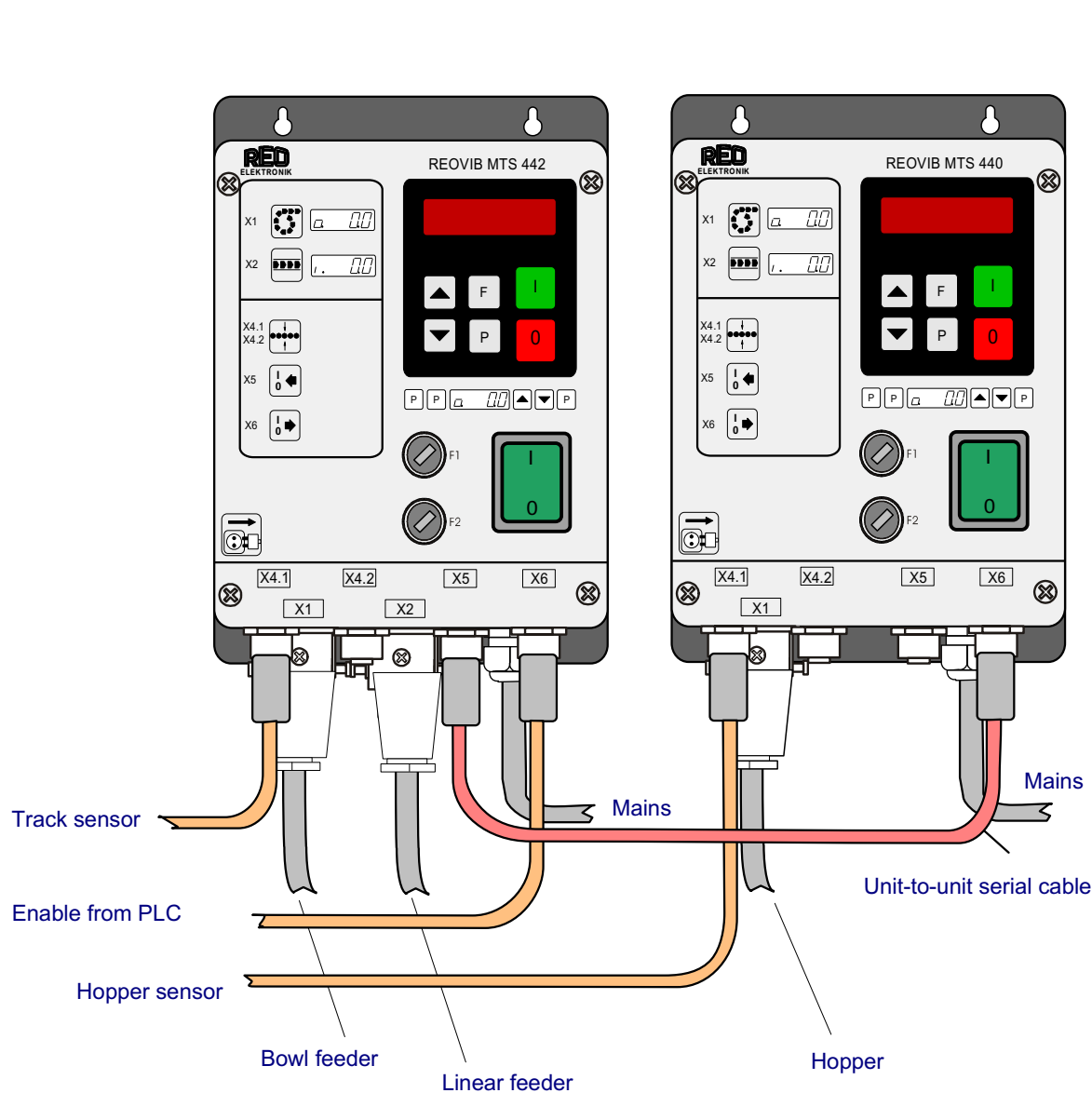

REOVIB MTS 440
Hopper Channel 1

REOVIB MTS 442
Bowl feeder Channel 1
Linear feeder Channel 2

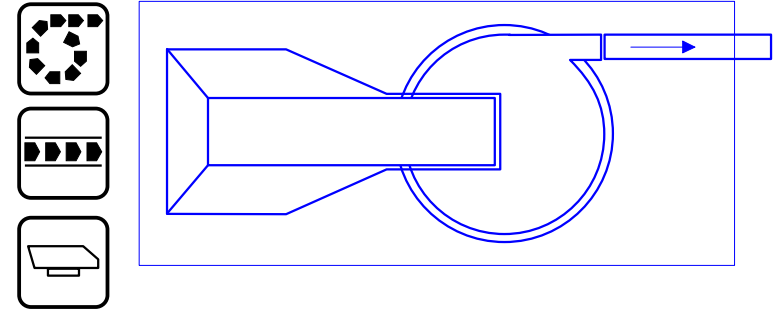

External enable signal:
With an external 24 V, DC enable signal from a PLC, the linear feeder and therefore also the upstream controllers can be enabled or disabled, for example.

Interlock settings of MTS 442:
Menu "C003": Channel 2 disables Channel 1 "i.-o." = I
Menu "C020": Invert enable "o.-En." = I
Menu "C021": Invert enable "i.-En." = 0

Interlock settings of MTS 440:
Menu "C020": Invert enable "o.-En." = I

Interlocking with hopper control via a connection cable (PIN 3-3, 4-4) from Status MTS 442 (X5) to Enable MTS 440 (X6).

Without external enable signal to MTS 442:
Menu "C021": Invert enable "i.-En." = I

Triple control of linear feeder and bowl feeder with belt hopper by combining REOVIB MTS 442 and VAREOTRON 166

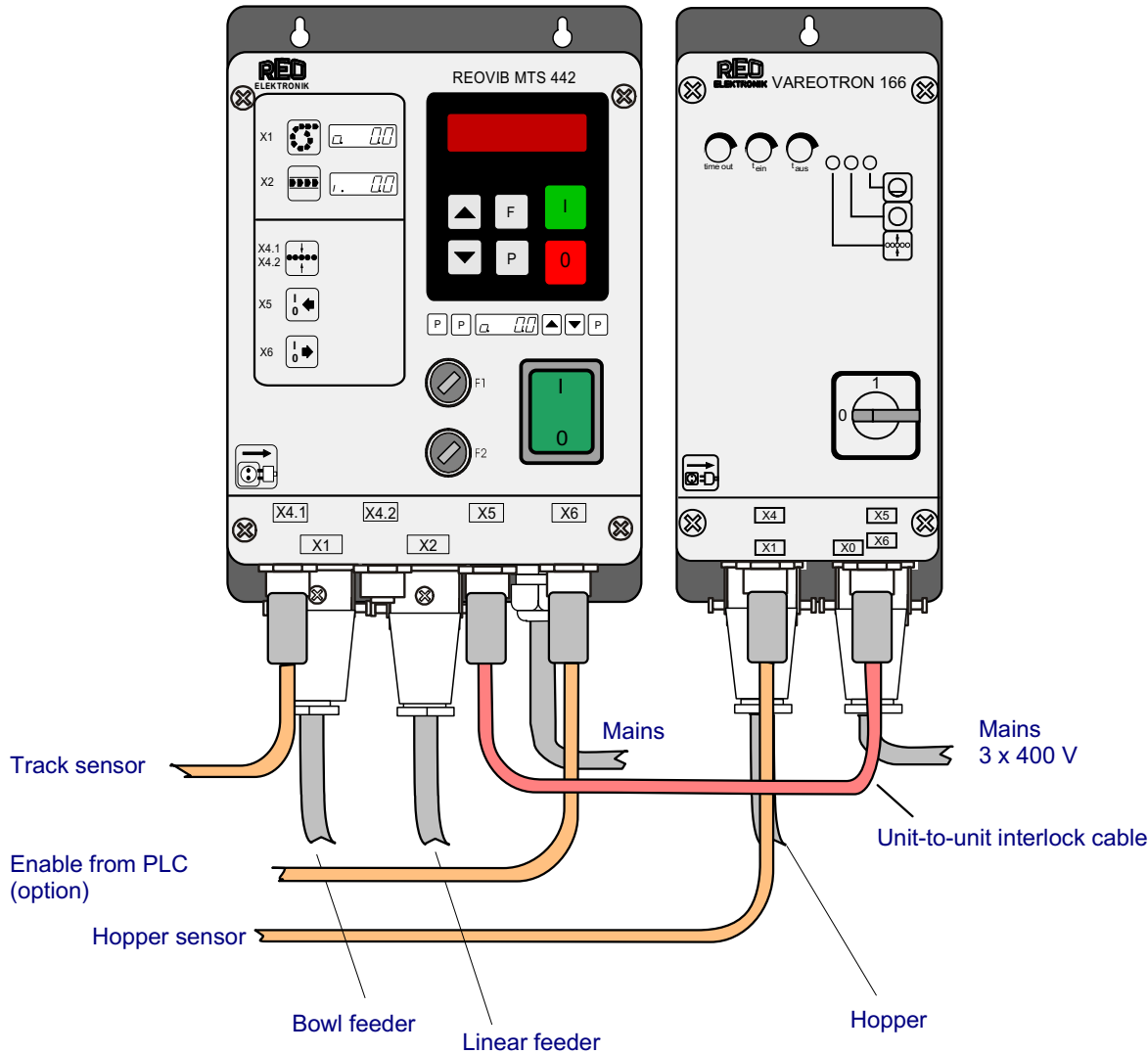

VAREOTRON 166
Hopper

REOVIB MTS 442
Bowl feeder Channel 1
Linear feeder Channel 2

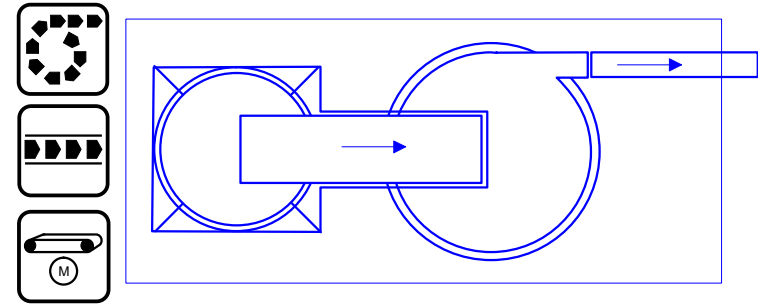

External enable signal:

With an external 24 V, DC enable signal from a PLC, the linear feeder and therefore also the upstream controllers can be enabled or disabled, for example.

Interlock settings of MTS 442:

Menu "C003": Channel 2 disables Channel 1	"i. - o." = 1
Menu "C020": Invert enable	"o.-En." = 1
Menu "C021": Invert enable	"i.-En." = 0

Interlocking with hopper control via a connection cable (PIN 3-3, 4-4) from Status MTS 442 (X5) to Enable VAREOTRON 166 (X4)

Without external enable signal to MTS 442:

Menu "C021": Invert enable "i.-En." = 1

Examples of signal connections

Bowl feeder and linear feeder

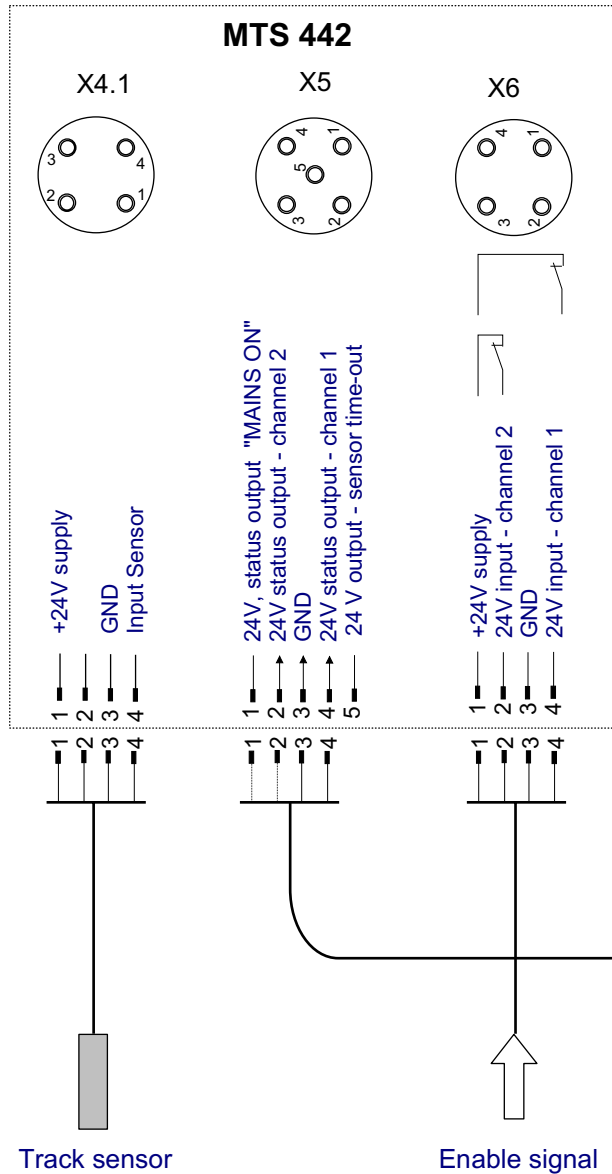

Hopper

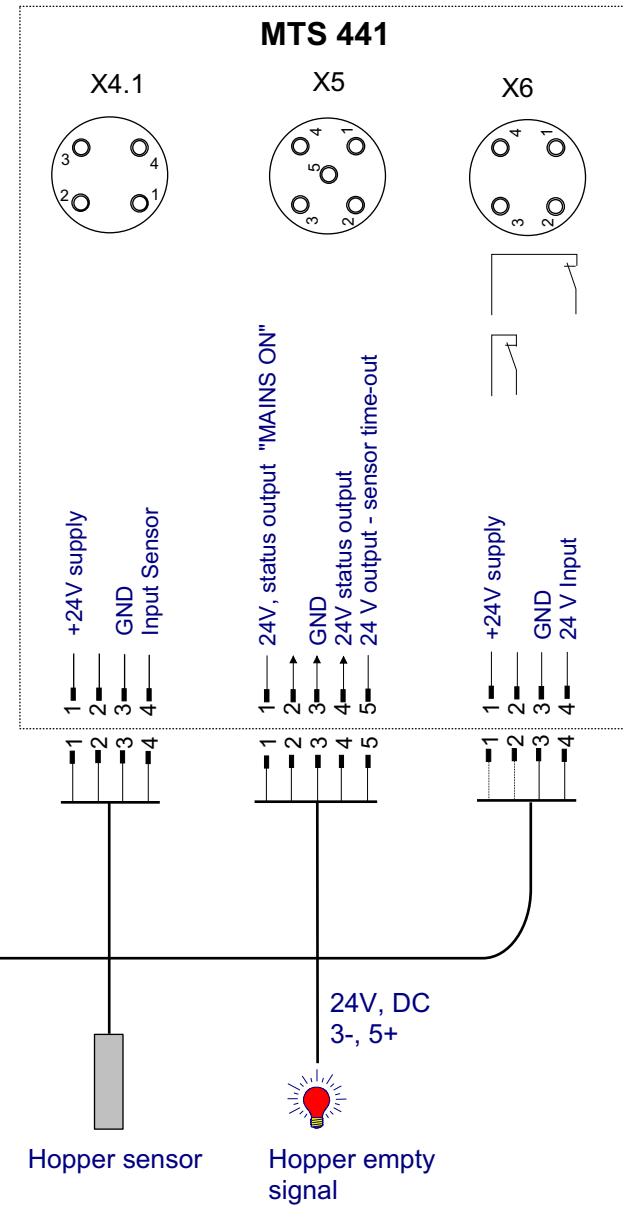

REOVIB MTS 443

Simple track control section with air blast valve in the bowl feeder

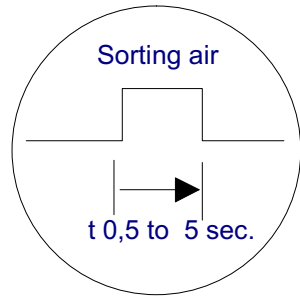

Identifies parts in wrong position and initiates an air blast

Air valve, switches on with the bowl feeder and switches off with a delay time after the bowl feeder has stopped

Identifies the stored parts on the linear feeder and stops or starts the bowl feeder with a time delay.

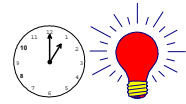

Time out message when the track sensor does not see parts after a preset delay time has expired



Particle sensor

Track sensor

Linear feeder

Level sensor

Bowl feeder

Hopper

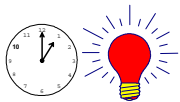

Time out message when the level sensor does not see parts after a preset delay time has expired

Detects the parts level in the bowl feeder and controls the hopper

- Linear feeder controller
- Bowl feeder controller with track control section on the linear feeder and empty signal (time out)
- Extra part sensor for air blast if a particle is in wrong position
- Hopper controller with level sensor and empty signal (time-out)
- Air valve to support the flow of particles from the bowl feeder to the linear feeder

REOVIB MTS 443

Track control section with "Parts-present" message

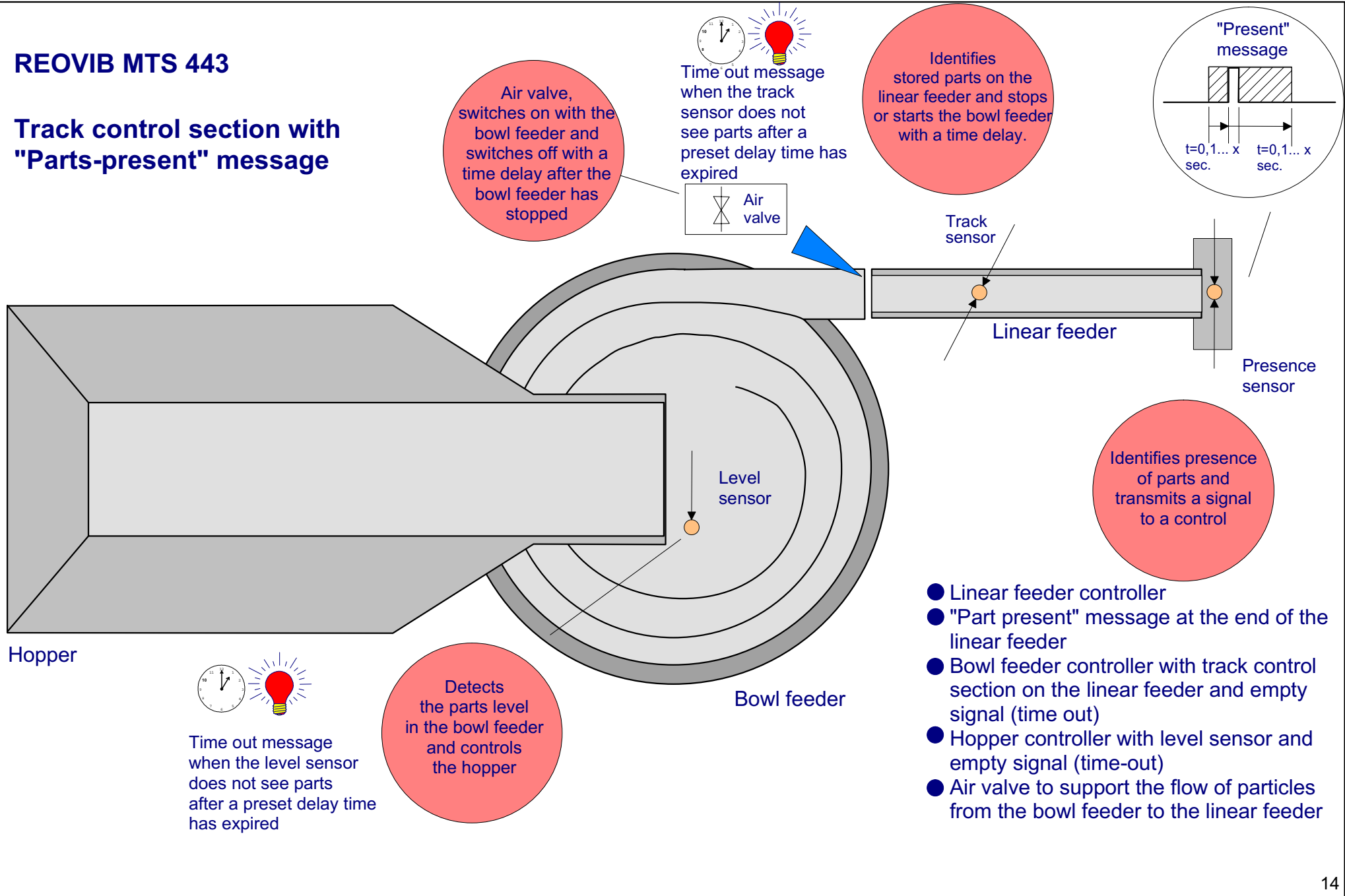

Air valve, switches on with the bowl feeder and switches off with a time delay after the bowl feeder has stopped

Time out message when the track sensor does not see parts after a preset delay time has expired

Identifies stored parts on the linear feeder and stops or starts the bowl feeder with a time delay.

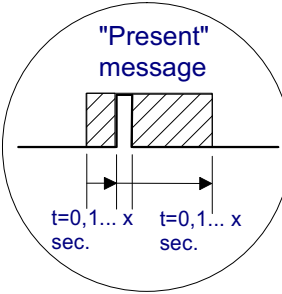

Track sensor

Linear feeder

Presence sensor

Level sensor

Identifies presence of parts and transmits a signal to a control

Hopper

Bowl feeder

Time out message when the level sensor does not see parts after a preset delay time has expired

Detects the parts level in the bowl feeder and controls the hopper

- Linear feeder controller
- "Part present" message at the end of the linear feeder
- Bowl feeder controller with track control section on the linear feeder and empty signal (time out)
- Hopper controller with level sensor and empty signal (time-out)
- Air valve to support the flow of particles from the bowl feeder to the linear feeder

REOVIB MTS 443

MIN/MAX-track control section

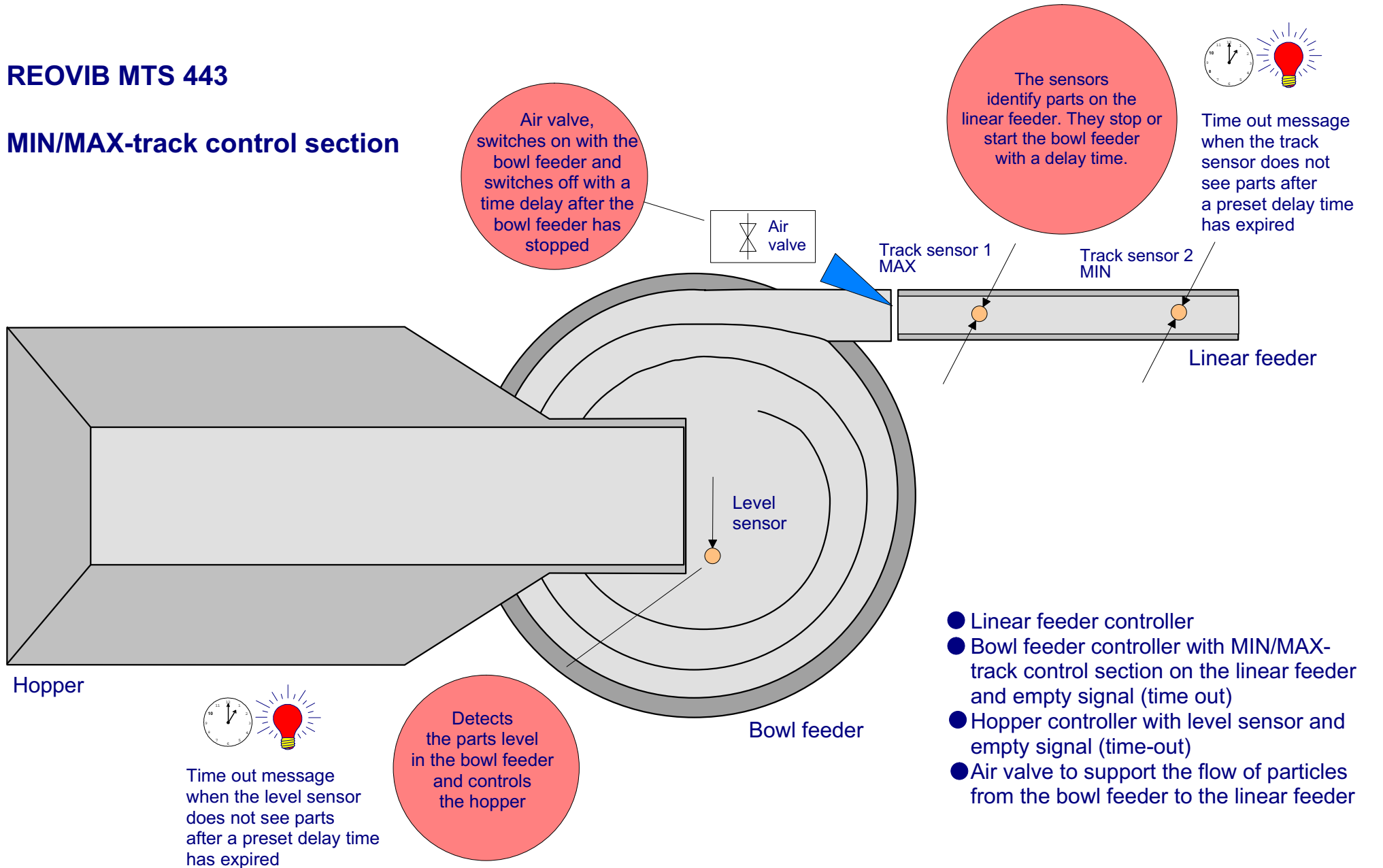

REOVIB MTS 443

2-track control section

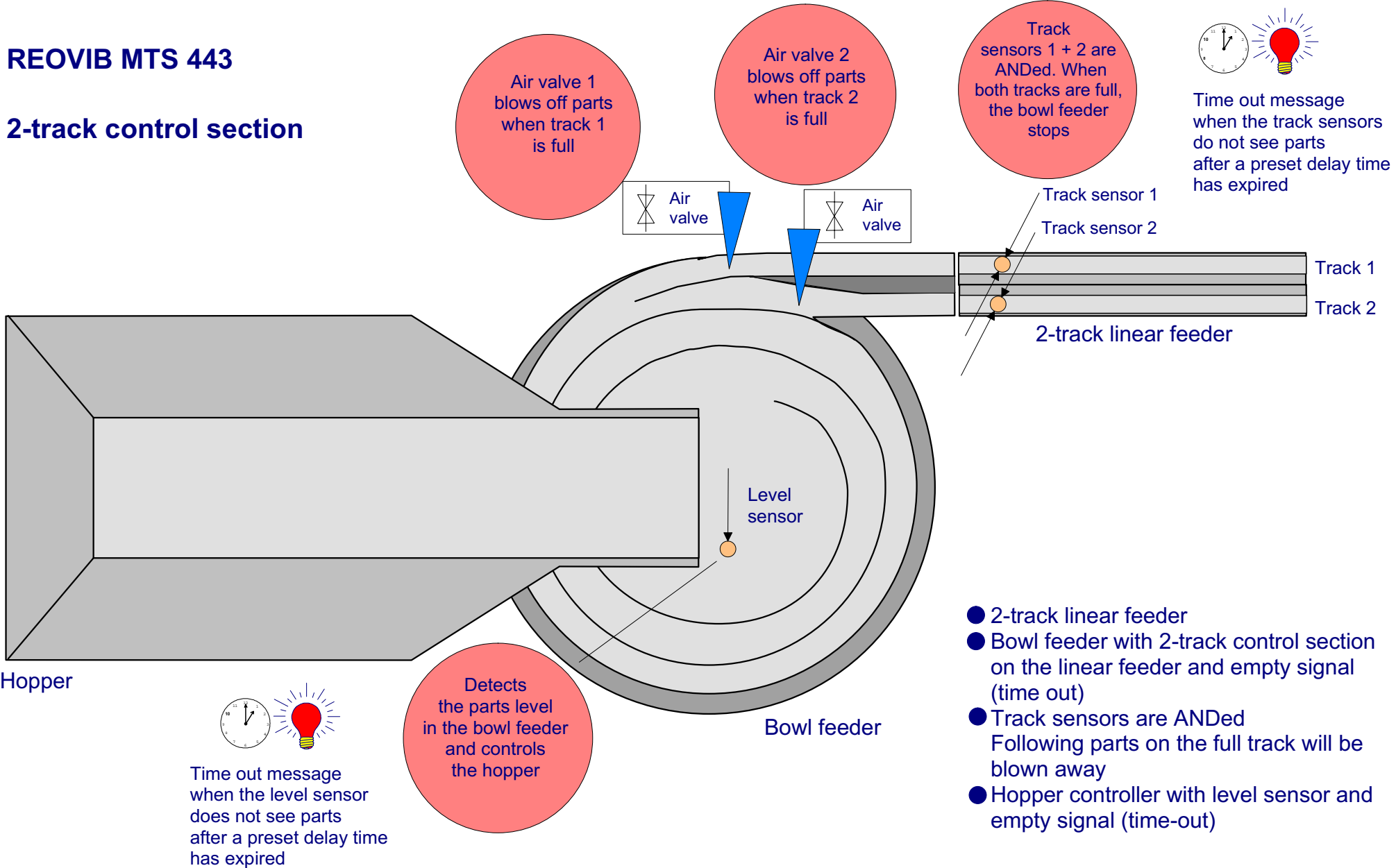

- 2-track linear feeder
- Bowl feeder with 2-track control section on the linear feeder and empty signal (time out)
- Track sensors are ANDed
Following parts on the full track will be blown away
- Hopper controller with level sensor and empty signal (time-out)