

Power Inductors (Chokes)

Whoever stops trying to be better
has stopped being good.

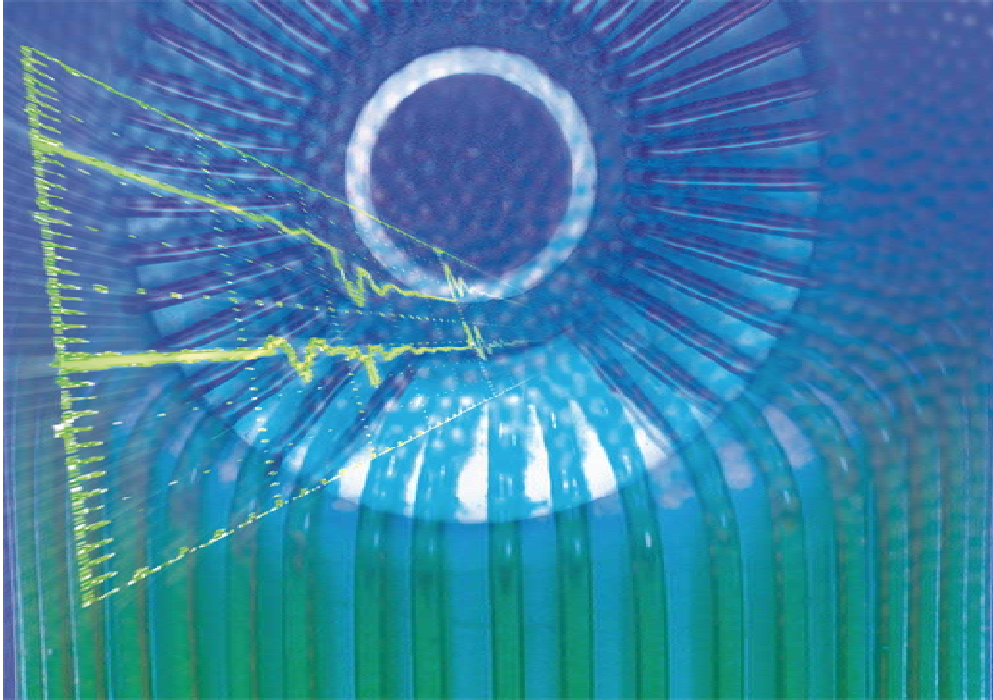

Introduction

Whenever electrons flow through a conductor a magnetic field will develop around it and this effect is called electromagnetism. The magnetic field affects the alignment of electrons within atoms causing a physical force to exist between atoms and can affect matter at a distance, through empty space. The magnetic **field** can be measured in two ways: its **force** or the strength it has over a certain distance (symbol mmf and units Amp-turns) and its **flux** which is the total quantity of the field in space (symbol Φ and units Webers). The amount of field flux that will develop in space is proportional to the amount of field force applied.

The magnetic field flux allows for a certain amount of “inertia” to accumulate in the electrons flowing through the conductor producing the field, and inductors are designed to take advantage of this phenomenon. In simple terms the magnetic field around an inductor expands as the current flowing through it increases and collapses when the current decreases but because of the kinetic energy in the moving electrons this has a storage effect, or could otherwise be described as opposing the flow of current, acting as a load when current is increasing and a source when current is decreasing.

The ability of an inductor to store energy in the form of a magnetic field is called **inductance** and this is measured in the unit of the Henry (H). Inductors are more commonly known as **chokes** and in higher power applications they are sometimes referred to as **reactors**.

By forming the inductor into a coil creates a stronger magnetic field and the introduction of a solid core made from certain materials can increase the magnetic field strength even more. Other factors which affect the inductance are the number on turns of the coil (the greater the number of turns the higher the inductance) and the permeability of the core material. **Permeability** (symbol μ and units Tesla-meters per Ampere-turn) is a term used to describe a material’s ability to accept magnetic flux and an air-core has a permeability of one, whereas a soft iron-core for example has a permeability of 600 (both values are approximate).

The **field intensity** is a measure of the field force (mmf) distributed over the length of an electromagnet (symbol H and units Ampere-turns per meter) and this is sometimes referred to as the magnetising force. Field intensity determines **flux density** (symbol B and basic unit Tesla). H is obtained by knowing the mmf and dividing it by the length of material, whereas B is obtained by taking the total flux (Φ) and dividing it by the cross-sectional area of the material, and so by plotting B against H it is possible to get a normal magnetisation curve (or B-H curve) for any particular material. There are two important characteristics of this curve: as the field intensity increases and decreases the curve changes shape and displays **hysteresis** and as the maximum field intensity is approached the curve tends to level off because the flux gets crammed as fewer electrons remain that are able to be aligned. This levelling off is referred to as **saturation**. Designers of inductors try to minimise this effect by selecting a core so that its flux density never approaches saturation levels and the inductor operates on a more linear portion of its B-H curve.



Construction details

Core Materials

This document is concerned with power inductors or reactors and so the cores used mainly by REO are manufactured from laminations of electrical grade, grain orientated, silicon steel. The alignment of the atoms purposely created by the steel rolling process gives very high quality magnetic properties and very low AC losses in the rolling direction. Furthermore the high silicon content helps to reduce losses because it enhances desirable properties such as low coercivity (the intensity of the applied magnetic field to reduce the magnetisation of a material to zero) and permeability at low flux. Silicon also mechanically stabilises the steel and prevents aging.

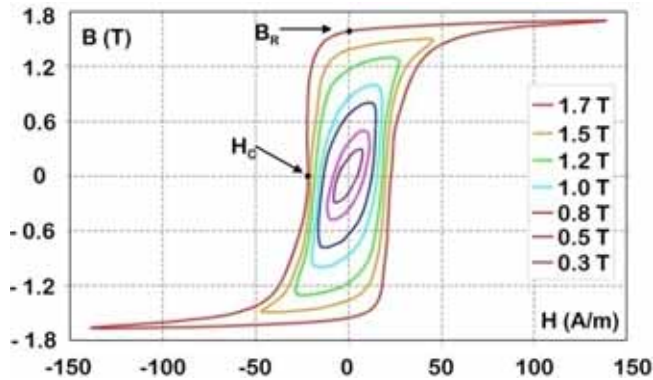

The diagram on the left shows a family of B-H loops measured with a flux density that is sinusoidally modulated at 50Hz with amplitude varying from 0.3 T to 1.7 T. The material is conventional grain-oriented steel. B_R denotes the remanence and H_C is the coercive field. The B-H loop is another name for the hysteresis loop.

Flux densities of more than 1.8 T are not used because cores with such a high density would easily run into saturation. For a constant inductance a flux density of between 1.3 and 1.4 T is chosen.

The cores are constructed from laminations which are 0.1mm to 1.0mm thick, to reduce eddy-current losses, and the higher the frequency the thinner the choice of lamination thickness. REO use the best quality, high-efficiency, cold-rolled, grain-oriented electrical steel, type M4, M5 or M6 which has a silicon content of between 2.8 and 3.5%, giving a permeability of approx. 15,000 and a maximum recommended operating flux density of 17 kilogauss. However, the frequency range is limited to a maximum of 18kHz and above this amorphous or ferrite cores have to be used instead.

Current rating is the most important factor to consider when designing a choke because both eddy-current and hysteresis losses are squared as current increases

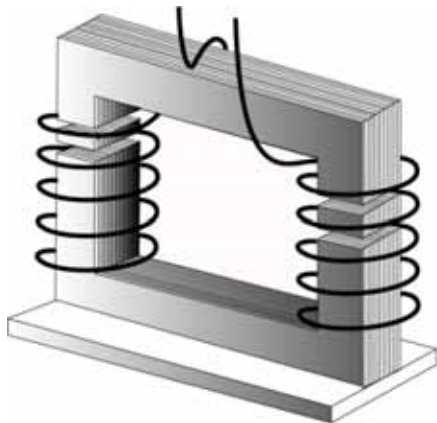

Air-gaps increase the magnetic resistance and allow chokes to be used with higher currents without running into saturation. It is important where these are positioned and ideally they should be inside the windings to reduce stray fields. It is better to have a number of small air-gaps rather than one large one because this also reduces the stray fields.

In DC link chokes ferrite blocks can be used in addition to air-gaps and this provides a constant inductance irrespective of load changes.

Air-cores

In addition to being very light and compact and having many other benefits besides short-circuit protection and smoothing air-cored chokes have the advantage that they hold their inductance even in saturated operation. Toroid constructions also exhibit very low stray-fields and so generate very little radiated interference. Air-cored chokes can also be applied in regenerative systems as link reactors for smoothing current, where effective cooling and weight are important considerations.



Windings

Winding wire is generally made from solid copper which has an insulation coating such as varnish, except in high-frequency applications (see later). The diameter of the wire is chosen for its ability to carry the required current, at the required frequency.

Number and cross-sectional area of turns and core cross sectional area determine the flux density, however, the more windings there are, the greater the stray flux. Therefore, the optimum flux density is achieved by a good mixture of winding turns, core material, total weight, cost of materials and the electromagnetic environment. The windings can be in the form of a coil or a toroid.

Environment Protection

The last process after a reactor has been built is to vacuum impregnate the core and winding assembly to prevent audible noise caused by magnetising forces whilst in operation and to provide mechanical rigidity.

Various methods of protection can then be applied depending on the specific application requirements. One solution is to have complete encapsulation using a polyester resin which can provide a seal that meets IP65 requirements. By enclosing the terminations in a suitable housing, it is possible for REO to build reactors that require no additional housing even when used in moist or dusty conditions.



Cooling

Because of their construction and the main materials used (copper and iron) power inductors are essentially quite large and heavy. Furthermore, it is important to ensure that cooling is very efficient to dissipate the heat generated by hysteresis and core losses and this is often achieved by leaving spaces between the different layers of windings (which also improves creepage clearances).

One technique widely used by REO for larger chokes, used in trains, where there is a natural cooling available caused by the forward motion of the train, is to have a number of close windings from the core outwards with spaces between them. Carefully positioned spacer blocks between the windings are used to direct the air from the bottom to the top of the choke. Not only does this greatly improve air flow but the electromagnetic field produced by the energised inductor has an axis which is at right-angles to the track and so does not cause interference with the track sensors used for signalling purposes.

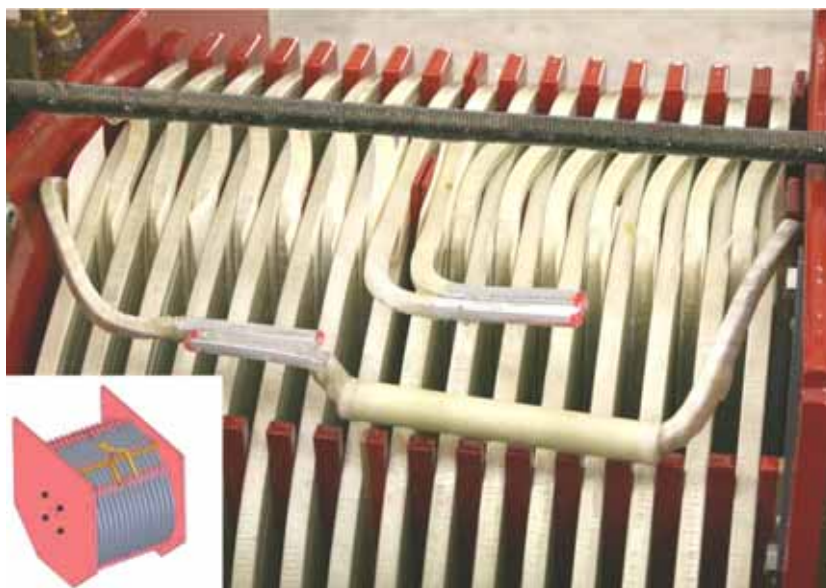

Water-cooling



Further size reduction can be achieved by forced-air cooling using fans or even better by using water-cooling, a method which REO has now perfected for use with many components.

The picture on the left shows a water-cooled line reactor which is used with frequency inverters for reducing harmonics, commutation notching and providing protection against transients.

Vacuum Impregnation and silicon coating

Greater isolation between current carrying components and other metal surfaces is achieved by vacuum impregnation with varnish after final assembly of the inductor. This also helps to reduce audible noise and mechanical movement caused by the magnetising and demagnetising of the winding coils and the core laminations.



Additional mechanical strength and protection against damage caused by dirt build-up or collision with solid objects is provided by an additional silicon coating.

Inductor Applications

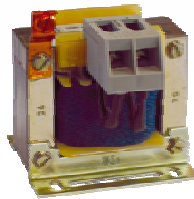
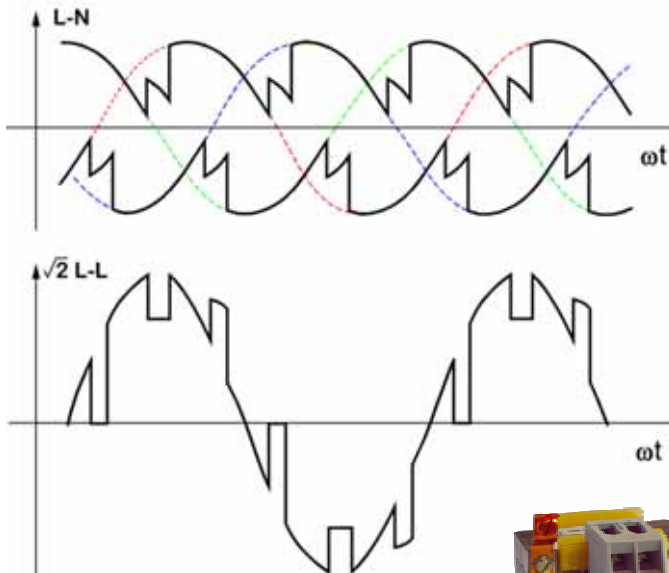
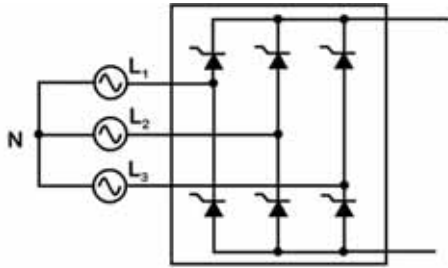

Commutation reactors

In silicon controlled rectifier circuits such as the one in the diagram, as one phase is turned off and another turned on (commutation) and for a very small duration of time there is a short-circuit between two phases. This causes the current to rise rapidly and the voltage to drop towards zero.

Commutation reactors can be fitted in the supply circuit to protect the semiconductors by limiting the short-circuit current.

Another consequence of commutation is that notches can occur in the supply voltage and these can take different forms, sometimes crossing the zero-point, which can cause problems with control equipment which uses the zero-crossing point as a time reference. Commutation reactors are not designed to protect the supply and the magnitude of the notches will depend on the supply impedance. To reduce notching on the power input it is necessary to use a line reactor (see later) connected in series.

Capacitor and Rectifier Protection

Most switch-mode power supplies have a DC link containing smoothing capacitors between the converter and inverter stages and these are discharged when the power supply is switched off or if there is mains power sag causing the capacitors to drain whilst trying to sustain the power output. When the capacitors recharge there is an instantaneous high current inrush, which can stress the capacitors and the converter's rectifiers.

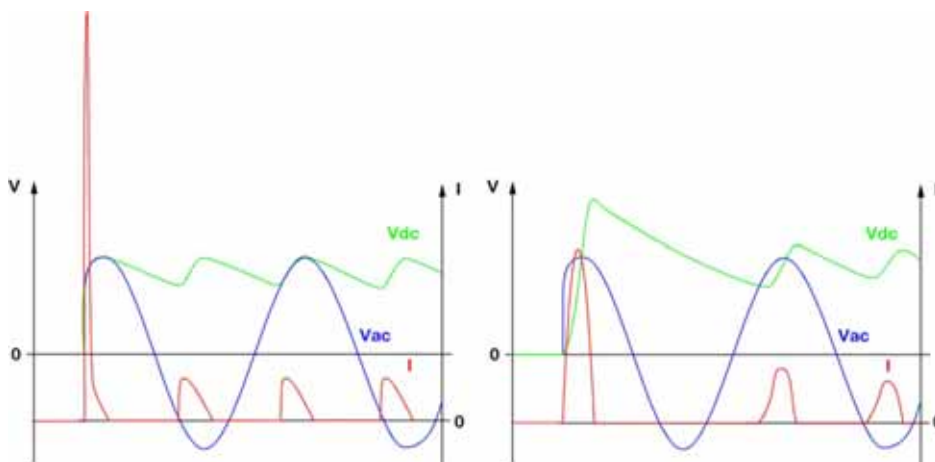

The diagram on the left illustrates how the supply current inrush is much higher for a few tenths of a micro-second than in the right-hand diagram which results in the additional impedance provided by a line reactor.

dV/dT Chokes

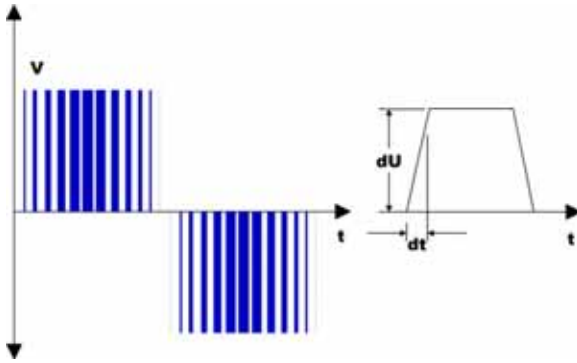

In fast switching circuits using semiconductors, such as those in converters and frequency inverters, the voltage rise is very rapid and can be more than $12\text{kV}/\mu\text{s}$. This can stress the insulation in motors and lead to premature failure. A choke on the output side of the inverter can reduce the rise rate to $500\text{V}/\mu\text{s}$ and hence protect the motor. For longer cable runs between the inverter and motor, a motor choke is required to reduce unacceptably high voltage peaks caused by cable voltage reflections and these also have a steep dv/dt .

Harmonics

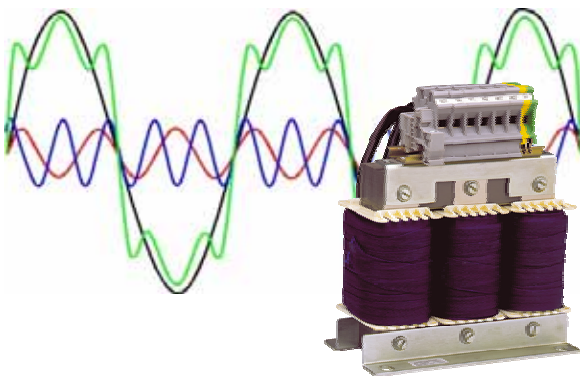

Any non-linear switching on the AC mains supply can be analysed and it will be found to comprise lots of harmonic frequencies, some predominant and some not depending upon the nature of the circuit and the components that are connected together. The problem with harmonics is that they do not contribute any useful power; they are undesirable because they distort the fundamental sine-wave shape which the grid operators are obliged to maintain and furthermore they excessive draw currents caused by the displacement power factor plus the combined harmonic power factors.

There are a number of ways to reduce harmonics and REO INDUCTIVE COMPONENTS AG specialise in passive solutions using chokes. One method is to fit a line reactor on the supply side of any electronic equipment that may be producing harmonics; hence the solution is said to be applied at source. Alternatively a larger central harmonic filter can be fitted to attenuate harmonics but this limits flexibility when any additional equipment is added to the circuit. Sometimes, for economy, rather than reducing all harmonics, the total harmonic distortion (THD) can be reduced to an acceptable level by using a filter which is designed to react to certain chosen harmonic frequencies which are creating the greatest harmonic distortion and in such cases an inductance/capacitance combination is used. In frequency inverters another technique that can be employed is to fit a choke in series with one line of the DC link.

REO line reactors are designed to block all harmonics and to allow the fundamental frequency to pass through and this is achieved because inductive impedance increases as frequency increases. The greater the inductance the higher the short-circuit voltage (the difference in voltage between a loaded and unloaded inductor) and the greater the harmonic attenuation that is achieved. The input impedance (U_K) of a line reactor is expressed as a percentage voltage drop and normally an inductor has a value of 2% or 4% but other values can be used depending on circumstances.



Common-mode Interference

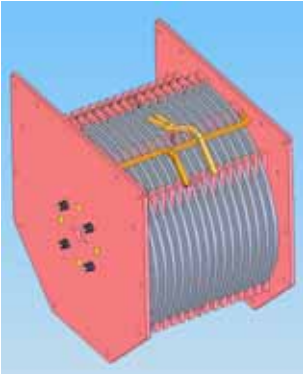

REO INDUCTIVE COMPONENTS AG has lots of experience with designing special products which are required to operate in different environments. Railway engineering demands that all components have to be as light and as compact as possible, they have to withstand extreme conditions, endure shock-loads, water spray and vibration, and are expected to give reliable service for at least 20 years. The picture on the right shows a typical example of a REO-Nieke air-cored choke for removal of common-mode RF noise in an auxiliary supply of a locomotive.

Higher frequencies

At higher frequencies (more than 18kHz) the use of electrical grade steel for making cores is no longer practical because the flux density has to be reduced as the frequency increases and the only way that this can be achieved is by having more core material. Despite the reduced flux density, the heating effects caused by higher losses are usually unacceptable. However, it is possible to use cores made from amorphous materials which can run at higher frequencies at normal flux levels and these are constructed from nano-crystalline ribbon that is wound into a toroidal form. Amorphous cores are easy to magnetise, have low hysteresis losses, high resistivity and low eddy-current losses.

Conventional windings are also unsuitable for high frequencies because of the tendency for current to flow in the outer surface of the wire – a phenomenon known as the “skin effect”. One solution is to use litz wire instead of copper wire for windings, which comprises lots of small strands of thin wires that are individually coated with an insulation material and woven together.

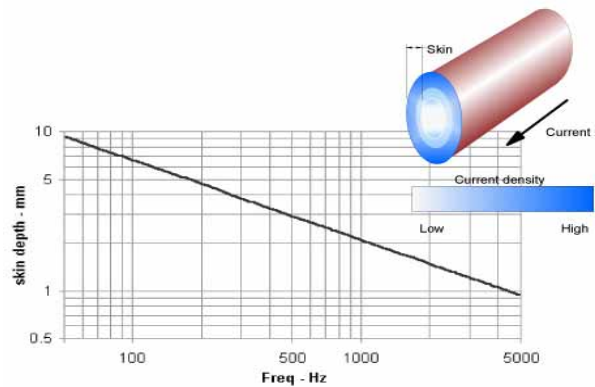

Production Facilities



Inductive components assembly area at Hennigsdorf for power inductors up to 2000 A current rating



REO INDUCTIVE COMPONENTS AG in Kyritz, Brandenburg for power inductors up to 160 A current rating.





REO World-wide Contacts

| | | |
|---|---|--|
| REO ELEKTRONIK AG | Brühler Strasse 100 D-42657 Solingen | Tel. +49 (0)212-8804-0 Fax +49 (0)212-8804-188 🌐www.reo.de ✉main@reo.de |
| REO INDUCTIVE COMPONENTS AG | Brühler Strasse 100 D-42657 Solingen | Tel. +49 (0)212-8804-0 Fax +49 (0)212-8804-188 🌐www.reo.de ✉main@reo.de |
| REO INDUCTIVE COMPONENTS AG Setzermann Medical Division | Schuldholzinger Weg 7 D-84347 Pfarrkirchen | Tel. +49 (0)8561-9886-0 Fax +49 (0)8561-9886-40 🌐www.reo.de ✉setzermann@reo.de |
| REO INDUCTIVE COMPONENTS AG IBK Drives Division | Holzhausener Strasse 52 D-16866 Kyritz | Tel. +49 (0)33971-485-0 Fax +49 (0)33971-485-90 🌐www.reo.de ✉ibk@reo.de |
| REO INDUCTIVE COMPONENTS AG Test and Power Quality Division | Brühler Strasse 100 D-42657 Solingen | Tel. +49 (0)212-8804-0 Fax +49 (0)212-8804-188 🌐www.reo.de ✉main@reo.de |
| REO INDUCTIVE COMPONENTS AG Train Technologies Nieke Division Centre of Competence | Erasmusstrasse 14 D-10553 Berlin | Tel. +49 (0)30-3670236-0 Fax +49 (0)30-3670236-44 🌐www.reo.de ✉mail@nieke.com |
| REO ELEKTRONIK AG | Im Halbiacker 5a CH-8352 Rätterschen | Tel. +41 (0)52-363-2820 Fax +41 (0)52-363-1241 🌐www.reo.ch ✉info@reo.ch |
| REO (UK) Ltd. | Units 2-4 Callow Hill Road Craven Arms Shropshire SY7 8NT | Tel. +44 (0)1588-673-411 Fax +44 (0)1588-672-718 🌐www.reo.co.uk ✉main@reo.co.uk |
| REO Engineering Services S.A. | Parc d'activités HERACLES Chaussée de Charleroi 91 bat 5 B-6060 Gilly (Charleroi) | Tel. +32 (0)71-287-716 Fax +32 (0)71-287-746 🌐www.reo.de ✉reoes@skynet.be |
| REO VARIAC S.A.R.L. | ZAC Du Clos aux Pois 1 6/8 rue de la Closerie-LISSES F-91048 Evry Cédex | Tel. +33 (0)1-6911-1898 Fax +33 (0)1-6911-0918 🌐www.reo.fr ✉reovariac@reo.fr |
| REO ITALIA S.r.l. | Via Treponti, 29 I-25086 Rezzato (BS) | Tel. +39 030-279-3883 Fax +39 030-249-0600 🌐www.reoitalia.it ✉info@reoitalia.it |
| REO CROMA Sp.zo.o. | ul. Pozaryskiego 28, bud 20 PL-04-703 Warszawa | Tel. +48 (0)22-812-3066 Fax +48 (0)22-815-690 🌐www.croma.com.pl ✉croma@croma.com.pl |
| REO-USA, Inc. | 3250 North Post Road, Suite #132 USA-Indianapolis, IN 46226 | Tel. +1 (0)317-8991-395 Fax +1 (0)317-8991-396 🌐www.reo-usa.com ✉main@reo-usa.com |
| REO-ESPAÑA 2002 S.A. | C/Manuel Ventura i Campeny 21B local 9 E-08339 Vilassar de Dalt (Barcelona) | Tel. +34 (0)937-509-994 Fax +34 (0)937-509-995 🌐www.reospain.com ✉info@reospain.com |
| REO Shanghai Inductive Components Co., Ltd. | No. 536 ShangFeng Road, Pudong, 201201 Shanghai, China | Tel. +86 (0)21-5858-0689 Fax +86 (0)21-5858-0289 🌐www.reo.cn ✉info@reo.cn |
| REO INDUCTIVE COMPONENTS AG Moscow Representative Office | Vienna House ul. Petrovka 27 107031 Moskau | Tel. +7 (0)495-956-55-57 Fax +7 (0)495-956-82-63 🌐www.reo.de ✉main@reo.de |
| NEEL REO SYSTEMS PVT.LTD. | 406 Saphire Arcade 42, M.G. Road Ghatkopar (E), Mumbai 400 077 | Tel. +91 (0)22-251643-26 Fax +91 (0)22-251643-17 🌐www.neelreo.in ✉info@neel.in |