



Operating Instructions  
**REOTRON SMP**  
Power Supply

REO (UK) LTD  
Units 2-4 Callow Hill Road, Craven Arms Business Park,  
Craven Arms, Shropshire SY7 8NT  
Tel. 01588 673411  
Fax 01588 672718  
[www.reo.co.uk](http://www.reo.co.uk)  
eMail: [sales@reo.co.uk](mailto:sales@reo.co.uk)

# REOTRON

Electronic Power Controller

## Technical safety information for the user

This description contains the necessary information for the correct application of the product described below. It is intended for use by technically qualified personal.

Qualified personnel are persons who, because of their training, experience and position as well as their knowledge of appropriate standards, regulations, health and safety requirements and working conditions, are authorised to be responsible for the safety of the equipment, at all times, whilst carrying out their normal duties and are therefore aware of, and can report, possible hazards (Definition of qualified employees according to IEC 364)

### Safety Instructions

The following instructions are provided for the personal safety of operators and also for the protection of the described product and connected equipment.



#### **Warning!**

Hazardous Voltage

Failure to observe can kill, cause serious injury or damage

- Isolate from mains before installation or dismantling work, as well as for fuse changes or post installation modifications.
- Observe the prescribed accident prevention and safety rules for the specific application.
- Before putting into operation check if the rated voltage for the unit conforms with the local supply voltage.
- Emergency stop devices must be provided for all applications. Operation of the emergency stop must inhibit any further uncontrolled operation.
- **Electrical connections must be covered**
- **The earth connection must be checked, for correct function, after installation.**

### Specified Use

The units described herein are electrical controllers for installation in industrial equipment. Not suitable for domestic applications.

**Contents**

Technical safety information for the user..... 1

Contents ..... 2

1.0 General ..... 3

2.0 Functions ..... 3

    3.0 Fault conditions..... 4

4.0 Combining several units ..... 4

5.0 Technical Data..... 4

6.0 Controls ..... 5

    6.1 Description of controls ..... 5

    6.2 How to use the controls ..... 5

    6.3 Setting procedure..... 5

    6.4 Displays..... 6

        6.4.1 Operating modes ..... 6

        6.4.2 Fault displays ..... 6

6.5 Parameter settings and ranges ..... 7

7.0 Settings..... 8

    7.1 Configure..... 8

    7.2 Minimum and maximum values ..... 8

    7.4 Reset error messages..... 9

    7.5 Save user settings ..... 9

    7.6 Recall saved settings ..... 9

    7.7 Hide / display menus..... 9

8.0 Connections..... 10

9.0 Dimensions ..... 11

10.0 Connection example..... 12

**1.0 General**

Primary switching circuit with DC output. Internal regulator for voltage, current or power control. Controlled from two setpoints (setpoint 1 = voltage, setpoint 2 = current) using either a 0...10 V, 0(4)...20 mA analogue signal or a Potentiometer. Setpoint 1 is used in the power regulation mode. The touch panel is used for making settings and keys "I" and "O" can be used for switching the output ON and OFF. **However, this does not provide isolation of the mains input.** The units can be used in parallel or series connection for providing higher power outputs.

Operating principles

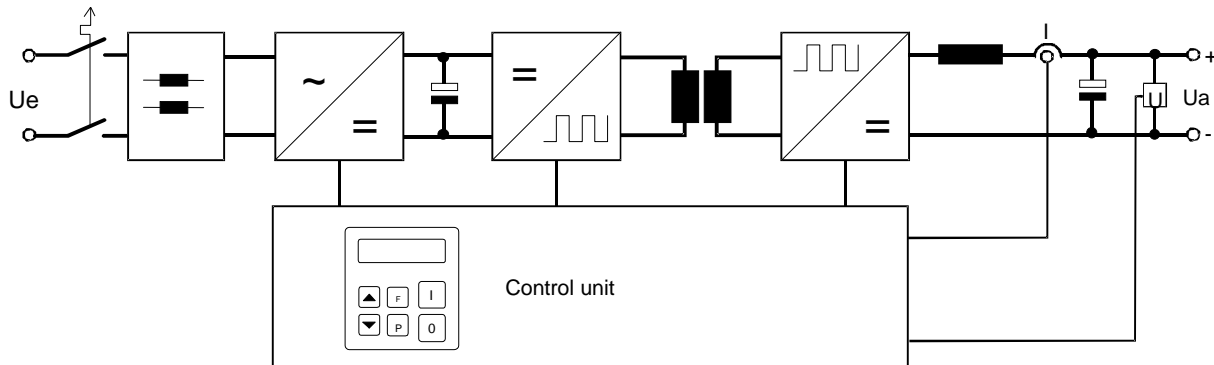

**2.0 Functions**

| Input:      |   | Terminals                                 |
|-------------|---|---|
| Set point 1 | Voltage set point: 0...10 V, DC, 0(4)...20 mA or Potentiometer 10 k<br>Or power set point | 1(-), 3(+), 4(+10V) / 2 (+) for 0...20 mA |
| Set point 2 | Current set point: 0...10 V, DC, 0(4)...20 mA or Potentiometer 10 k                       | 5(-), 7(+), 8(+10V) / 6 for 0...20 mA     |
| Enable      | Contact or 24 V, DC signal voltage  | 31(-), 32(+), 33(+24V)                    |
|             |   |   |

**Enable:**

24 V, DC signal on enable input ( 24V = ON).

External contact on terminals 32 and 33 or external 24 V signal on terminals 31(-) and 32(+).

**Voltage regulation (Set point 1)**

Set point 2 (Current) at +10V Ref. Link between terminals 7 and 8.

Connect voltage set point to terminals 1 – 4 (see connection diagram).

A maximum output current limit can be set in menu "C. 020".

**Current regulation (Set point 2)**

Set point 1 (voltage) at +10V Ref. Link between terminals 3 and 4.

Connect voltage set point to terminals 5 - 8 (see connection diagram).

A maximum voltage limit can be set in menu "C. 020".

**Power regulation (Set point 1)**

Set point 2 (Current) at +10V Ref. Link between terminals 7 and 8.

Connect power set point to terminals 1 – 4 (see connection diagram).

A maximum output current limit can be set in menu "C. 020".

### 3.0 Fault conditions

Faults conditions are displayed for:

|                    |        |     |
|--------------------|--------|-----|
| Over temperature   | Error  | HOT |
| Low mains voltage  | Lo.Po. |     |
| High mains voltage | Error  | OU  |

When a fault condition occurs the unit switches itself off and an error message is displayed. The error message must be cancelled in menu "C 009".

### 4.0 Combining several units

It is possible to connect units in series or in parallel. When parallel connection is used the outputs should be wired to a common terminal but in series connection the units can be linked together. In all cases the set points are connected in parallel. When a 0(4)...20 mA control signal is used a 500 ohm resistor must be connected across terminals 1 + 3 and 5 + 7 respectively. The current source must be capable of delivering at least 10V.

### 5.0 Technical Data

| Unit type             |        | REOTRON SMP<br>24-100                                  | REOTRON SMP<br>24-200 | REOTRON SMP<br>15-220 |
|-----------------------|--------|--|-----------------------|-----------------------|
| Input voltage         | [V]    | 3 x 400, +/- 10%                                       |                       |                       |
| Input frequency       | [Hz]   | 50 / 60  |                       |                       |
| Unit output power     | [W]    | 2400   | 4800                  |                       |
| Output current        | [A]    | 0...100  | 0...200               | 0...220               |
| Output voltage        | [V dc] | 0...24   |                       |                       |
| Ripple                | [mV]   | +/- 200  |                       |                       |
| Set point             |        | 0... +10 V, DC, 0(4)...20 mA,<br>Potentiometer 10 kOhm |                       |                       |
| Enable                |        | 24 V, DC or Contact                                    |                       |                       |
| Efficiency            |        | > 85 %   |                       |                       |
| Power factor          |        | 0,95   |                       |                       |
| Protection            |        | 19" IP 40  |                       |                       |
| Operating temperature |        | 0...+45 °C   |                       |                       |
| Storage temperature   |        | -20...+70 °C   |                       |                       |
|                       |        |  |                       |                       |
|                       |        |  |                       |                       |
|                       |        |  |                       |                       |

**6.0 Controls**

**6.1 Description of controls**

The unit is operated and set up by using six buttons that are used in conjunction with a LED display, in the front touch panel. All configuration and parameter settings can be made through this panel. The unit can be switched ON and OFF by using the “I” and “O” keys, however these **do not provide mains isolation**, they simply inhibit or enable the power semiconductors.

The “P”, “F” and arrow keys are used for setting the parameters.

The parameter settings are held under menus that are opened by entering user codes. A later section on settings provides a fuller description of menus.

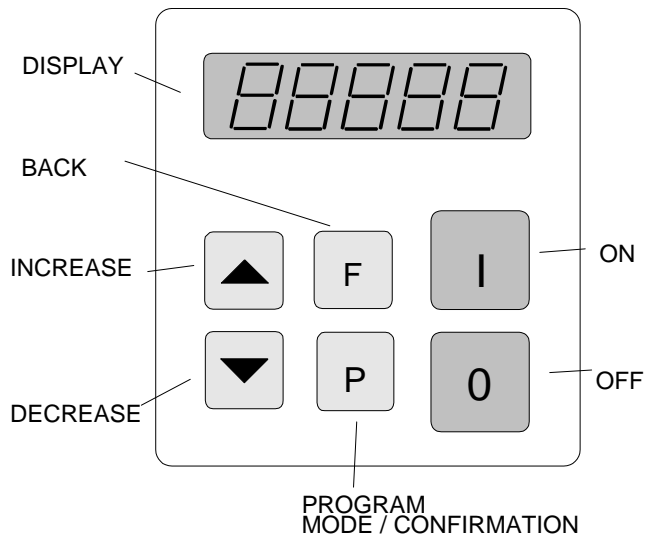

**6.2 How to use the controls**

Pressing the arrow key for short time will increase or decrease the displayed value by one division (a unit or tenth). The display will change in tens of units when the arrow keys are held down. To prevent unauthorised changes to the settings these are protected under operating menus. A user code must be entered to open the menus. There are different menus for the various functions.

**New values are saved upon leaving the programming mode or when a key is not pressed for 100 seconds.**

**6.3 Setting procedure**

Every adjustment is made by firstly pressing the programming key “P”. The following flow diagram should help in clarifying the procedure:

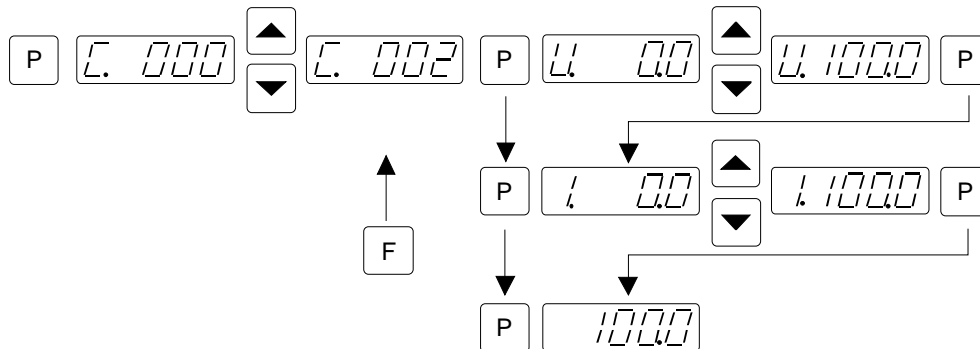

1. Press the “P-Key”.
2. Select the Code Number by using the arrow keys.
3. Press the “P-Key” again. The first menu position will be displayed. Further menu positions will be displayed by repeatedly pressing the “P-Key” (scrolling).
4. When the required menu position has been reached, the setting can be changed with the arrow keys.
5. Continue pressing the “P-Key” for the next menu position or until the end position is reached ie when the setpoint is displayed. To exit the menu quickly press the “P-Key” for a long time (5 secs.).
6. The “F-Key” allows the user to go back to a previous menu point..

## 6.4 Displays

During normal operation "run" is displayed on the LED panel. In the programming mode a shortened description of the function is displayed. New settings are upon when leaving the programming mode or if no keys are pressed for 30 seconds delay, then the settings will be saved.

### 6.4.1 Operating modes

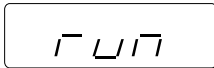

Normal operation

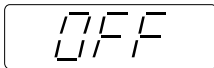

No unit enable

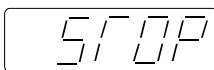

Unit stopped by using the "O-Key"

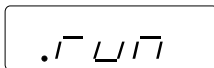

Illuminated left-hand, decimal point in the display. Current regulation, maximum current for the unit or the selected current limit has been reached.

### 6.4.2 Fault displays

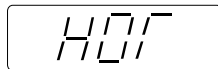
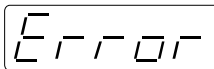

Over temperature

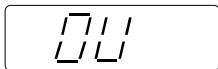
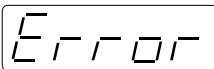

Input voltage too high

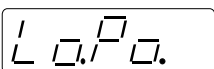

Input voltage too low

## 6.5 Parameter settings and ranges

| Parameter                              |             | Code      | Factory settings | Access code: |
|--|-------------|-----------|------------------|--------------|
| • Disable external set point           | 0 / 1       | E.S.O.    | 0                | 003          |
| • 4...20 mA                            | 0 / 1       | 4.20      | 0                | 003          |
| • Power regulation                     | 0 / 1       | E.F.P.    | 0                | 003          |
| • Minimum voltage                      | 0...100 %   | U.        | 0                | 020          |
| • Minimum current                      | 0...100 %   | I.        | 0                | 020          |
| • Minimum power                        | 0...100 %   | P.        | 100              | 020          |
| • Maximum voltage                      | 50...100 %  | <u>u.</u> | 100              | 020          |
| • Maximum current                      | 50...100 %  | <u>i.</u> | 100              | 020          |
| • Maximum power                        | 50...100%   | <u>p.</u> | 100              | 020          |
| • Soft start                           | 0...60 sec. | <u>t.</u> | 0,1              | 020          |
| • Soft stop                            | 0...60 sec. | <u>t.</u> | 0,1              | 020          |
| •                                      |             |           |                  |              |
| • Internal set point voltage (display) | 0...100 %   | U.        | 0                | 002          |
| • Internal set point current (display) | 0...100 %   | I.        | 0                | 002          |
| • Internal set point power (display)   | 0...100 %   | P.        | 0                | 002          |
| •                                      |             |           |                  |              |
| • Error reset                          |             | Clr.Er.   |                  | 009          |
| • Save settings                        |             | PUSH.     |                  | 143          |
| • Return to factory settings           |             | FAC.      |                  | 210          |
| • Return to user settings              |             | US.PA.    |                  | 210          |
| • Disable programming modes            | 0 / 1       | Hd.C.     | 0                | 117          |
| •                                      |             |           |                  |              |
| • Actual value set point ( %)          |             |           |                  |              |
| • Voltage                              |             | u.        |                  | 050          |
| • Current                              |             | i.        |                  | 050          |
| • Power                                |             | P.        |                  | 050          |
| •                                      |             |           |                  |              |
| • Actual feedback (%)                  |             |           |                  |              |
| • Voltage                              |             | u.        |                  | 051          |
| • Current                              |             | i.        |                  | 051          |
| • Power                                |             | P.        |                  | 051          |

**7.0 Settings**

Code 002

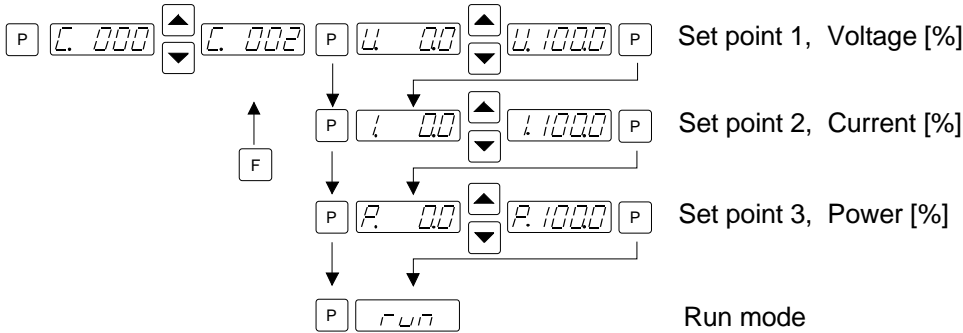

**7.1 Configure**

Code 003

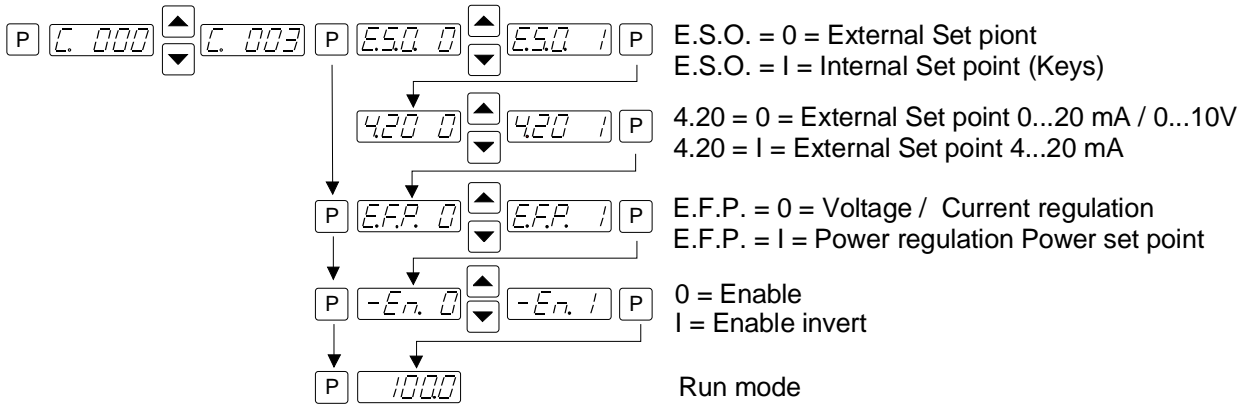

**7.2 Minimum and maximum values**

Code 020

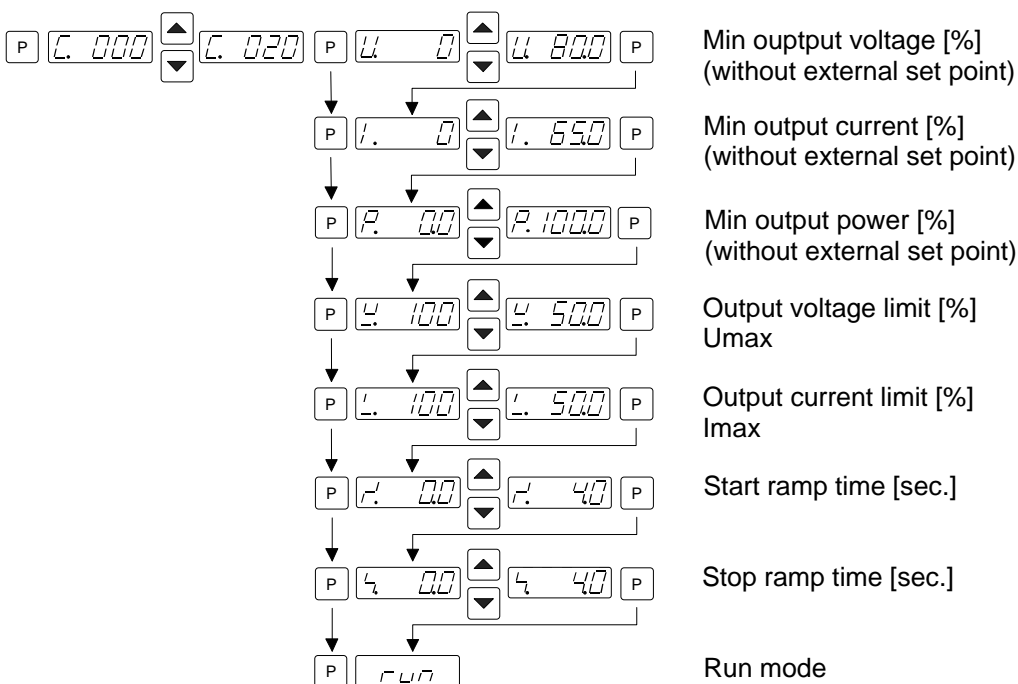



**8.0 Connections**

Control terminals

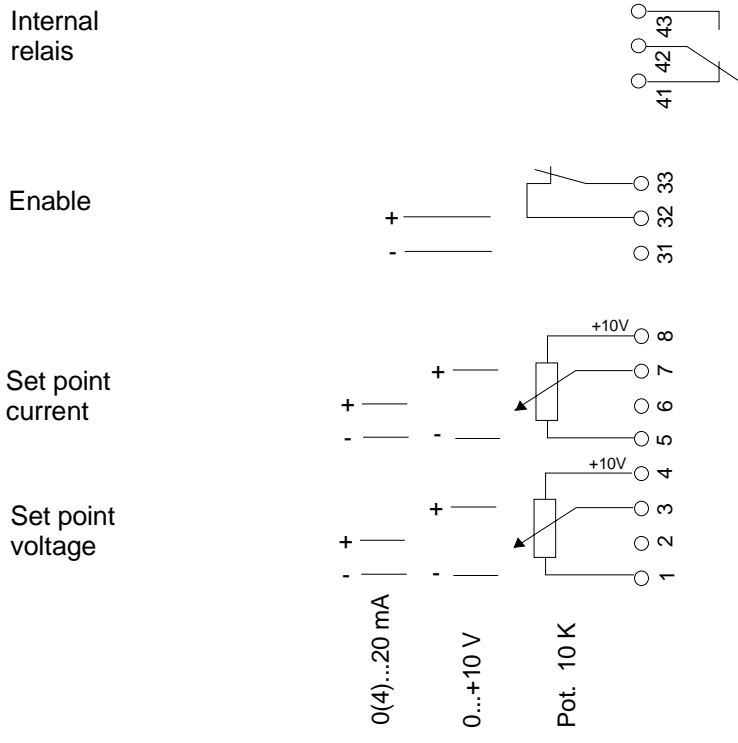

Power terminals

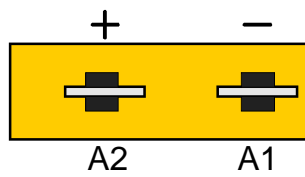

**9.0 Dimensions**

| Dims.   | A   | B   |
|---------|-----|-----|
| SMP 100 | 405 | 365 |
| SMO 200 | 505 | 465 |

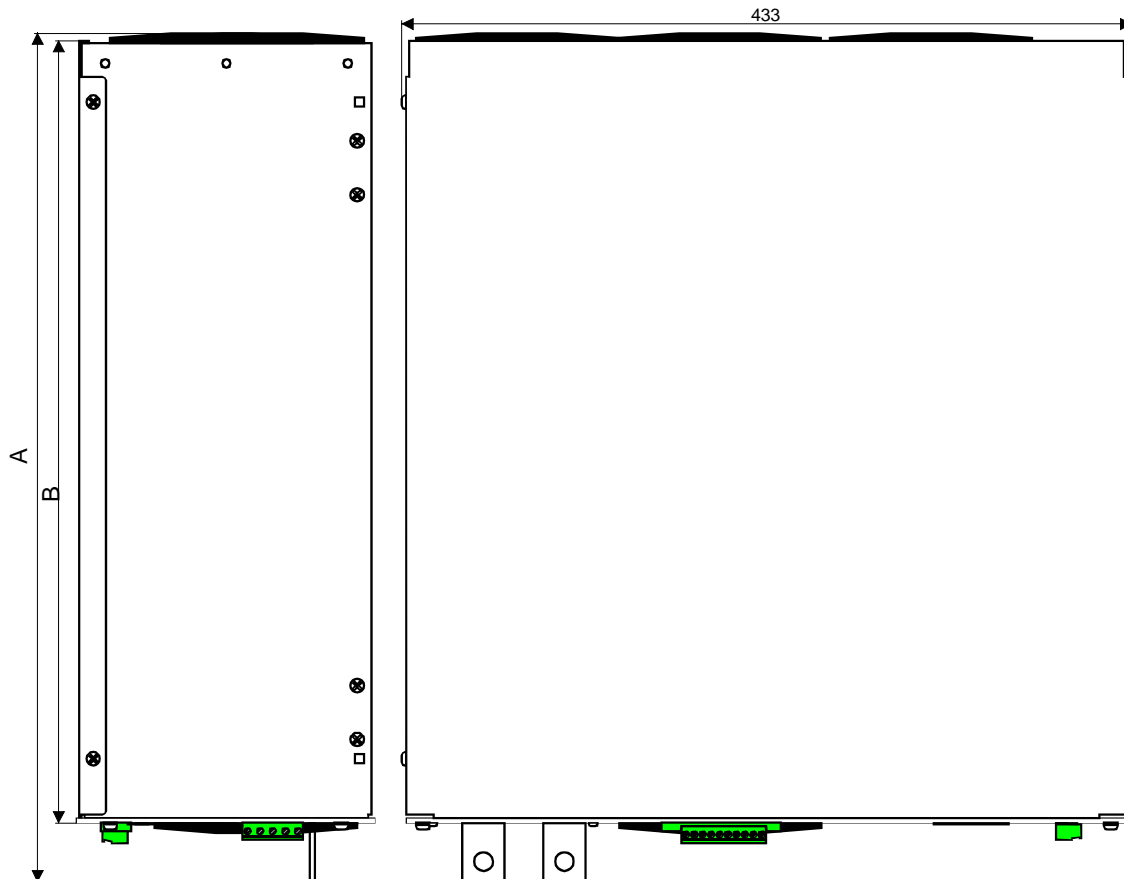
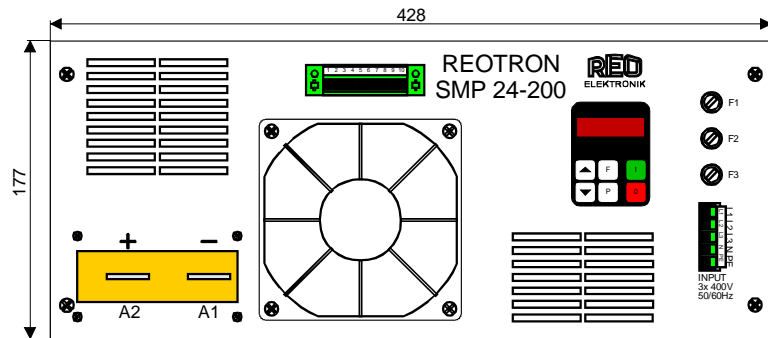

**10.0 Connection example**

Parallel connection

