



REO

**The Engineers' Practical  
Guide to EMI Filters**

# Author



**Dr. Min Zhang**

**Mach One Design, An Associate Of Cherry Clough Consultants LTD**

Dr. Min Zhang received his PhD within Newcastle University's Electrical & Electronics Engineering department in 2013. His research was in novel power switching schemes to reduce EMI emissions, and his research papers have received many citations.

Since then, he has worked as an EMC specialist on milestone projects with Dyson Technology, UK. With a proven track record designing state-of-the-art electronics and electric machines with minimal EMC issues, Min then established the EMC capability for the Dyson Electric Vehicle project.

Following the closure of that project, Min started Mach One Design and became associated with Cherry Clough Consultants Ltd to provide independent expertise in good, cost-effective EMC design, worldwide.

Min's in-depth knowledge in power electronics, digital electronics, electronic machines and product design is sure to benefit your product's design, helping you win the race against time and cost.

Contact Dr. Min Zhang by email: [min.zhang@mach1design.co.uk](mailto:min.zhang@mach1design.co.uk) or call: +44(0)1869246087 or visit website: [www.mach1design.co.uk](http://www.mach1design.co.uk)

# Contents

<b>Chapter 1 - Introduction</b>		
1.0	Introduction	8
<b>Chapter 2 - Inductors</b>		
2.0	Inductors	9
2.1	A Basic Model Of An Inductor	11
2.2	Differential-Mode And Common-Mode Chokes	13
2.3	Inductor Structures	17
2.4	General Layout Rules For Inductors	20
<b>Chapter 3 - Capacitors</b>		
3.0	Capacitors	21
3.1	A Basic Model Of A Capacitor	22
3.2	Electrolytic Capacitors	23
3.3	Ceramic Capacitors	27
3.4	Film Capacitors	30
3.5	Capacitance Degradation Due To Ageing And The Environment	31
3.6	General Layout Rules For Capacitors	32
<b>Chapter 4 - Ferrite Cores</b>		
4.1	Ferrite Cores	33
<b>Chapter 5 - Resistors</b>		
5.1	Resistors	35
<b>Chapter 6 - Filter Design</b>		
6.1	Insertion Loss	37
6.2	Design Filters With Simulation	41
6.3	Mode Conversion	44
<b>Chapter 7 - Filter Layout</b>		
7.1	Location	45
7.2	Common Mistakes And How To Avoid Them	48
7.3	Cost-Effective Filter Implementation	50
<b>Chapter 8 - Immunity And Other Aspects</b>		
8.1	Immunity	51

# Why Should You Read This Book?

As a design engineer, does Electromagnetic Interference (EMI) always seem like ‘black magic’? Are you spending a great amount of time doing multiple iterations of your board – only to find the product failing the EMC test again and again? Do you often install a filter even when there is no specific problem in the hope that would “help” if a problem should occur? Are you confident in your filter design for your product? Wondering what needs to be taken into account when designing a filter? Would you like to learn how to characterise your filter and simulate its performance using a simple SPICE based simulation tool? Then this is the book for you!

The purpose of this guide is to help engineers understand the fundamentals of EMI and to design effective filters so that a product will pass the EMC standards. To do so, we need to spend some time understanding the fundamentals. The subject of physics is quite complex and mathematical equations often frighten people away. What we have learnt at university often cannot solve all the practical problems that we face in the real engineering world. Therefore, in this book the underlying principles of EMI will be explored without complex mathematics.

By definition, filters are a network of passive components such as capacitors, inductors and resistors that provide attenuation to signals within a certain bandwidth. From here, we can have a capacitive filter, an inductive filter, an R-C filter, an L-C filter, a C-L-C (or  $\pi$ ) filter, an L-C-L (T) filter, etc. Which filter configuration should we choose for the design at hand? This question will be answered here. There are also active filters, but they are beyond the scope of this work.

Nonlinearity is often overlooked by engineers; this is particularly true when the frequency increases. For instance, at high frequencies, the dielectrics of capacitors are nonlinear. For magnetic materials, permeability falls off with frequency. The B-H curve of a magnetic component shows a nonlinear relationship. As a magnetic core approaches saturation, the demand for magnetising current increases significantly. These design considerations will also be addressed in this book.

Most EMI issues are both differential and common mode in nature; filters are therefore most effective if they can provide attenuation to both types of noise. For instance, a common-mode choke (CMC) will inevitably have a leakage field which results in differential-mode filtering (even a bifilar wound CMC will have about 0.1% leakage inductance). Both differential and common mode chokes are discussed in this book.

Filter performance can be easily modelled using simulation tools. Among many of the simulation tools, a SPICE based simulation is quick and easy to build. With sufficient allowance for the parasitic parameters, a SPICE based simulation model can give accurate filter performance that can match the test results. Many simulations are demonstrated in this volume.

# List Of Figures

FIGURE 1	THE FUNCTION OF AN INDUCTOR IN A FILTER IS TO PROVIDE A HIGH IMPEDANCE PATH	9
FIGURE 2	UNDERSTANDING THAT ENERGY IN AN INDUCTOR IS STORED IN DIELECTRICS SUCH AS AIR IS IMPORTANT. SHOWN, <a href="#">REO EDGE WOUND INDUCTOR</a>	11
FIGURE 3	BASIC MODEL OF AN INDUCTOR AND ITS IMPEDANCE CURVE	13
FIGURE 4	DEMONSTRATION OF DIFFERENTIAL AND COMMON MODE CURRENT LOOP IN A SMPS	15
FIGURE 5	COMMON-MODE CURRENT FORMS A LOOP; AN ANTENNA STRUCTURE IN THIS LOOP SUCH AS THIS CABLE WILL THEN RADIATE STRONGLY	15
FIGURE 6	DEMONSTRATION OF DIFFERENTIAL AND COMMON MODE CURRENT LOOP IN A SMPS	16
FIGURE 7	FILTERS IN A TYPICAL THREE-PHASE MOTOR DRIVE SYSTEM	16
FIGURE 8	SIMPLIFIED SYSTEM DIAGRAM OF AN 11 KW ON-BOARD CHARGER (OBC)	17
FIGURE 9	TWO CMCS USED IN A TWO-STAGE FILTER FOR A DC-DC CONVERTER - <a href="#">REO TYPE CHI131</a>	19
FIGURE 10	(A) SHIELDING THE INDUCTOR USING COPPER TAPE (B) CONDUCTED EMISSION SCAN BETWEEN THE SHIELDED INDUCTOR AND UN-SHIELDED INDUCTOR	20
FIGURE 11	COMMON MAGNETIC COUPLING MECHANISMS	22
FIGURE 12	BASIC MODEL OF A CAPACITOR AND ITS IMPEDANCE CURVE	24
FIGURE 13	ELECTROLYTIC CAPACITORS ARE USED AS A PRIME ENERGY STORAGE DEVICE	25
FIGURE 14	SIMULATION DEMONSTRATION OF AN ELECTROLYTIC CAPACITOR'S DAMPING	27
FIGURE 15	"HOT LOOP" AREAS IN THE SYSTEM	28
FIGURE 16	SURFACE MOUNT MULTILAYER CERAMIC CAPACITORS IN AN ENGINEERING KIT	29
FIGURE 17	LONG TRACE CONNECTION TO THE MLCC INTRODUCES EXTRA INDUCTANCE	30

FIGURE 18	RESISTORS ARE USED TO DAMP THE RESONANCE CAUSED BY MLCCS	31
FIGURE 19	A CERAMIC DISC CAPACITOR	31
FIGURE 20	CERAMIC DISC CAPACITORS PROVIDE EMI SUPPRESSION AND PRIMARY-SECONDARY DECOUPLING	32
FIGURE 21	EMI IMPROVEMENT WITH ADDED Y-CAPS	32
FIGURE 22	FILM CAPS (IN THIS CASE, X-TYPE) ARE USED IN APPLICATIONS SUCH AS DC-DC CONVERTERS	33
FIGURE 23	FERRITE CORES FOR ROUND CABLES	36
FIGURE 24	DEMONSTRATION OF USING FERRITE CORES ON CABLES	37
FIGURE 25	RESISTORS ARE USED TO MATCH THE IMPEDANCE OF A TRANSMISSION LINE SYSTEM, WHICH IS CRITICAL FOR HIGH-SPEED DATA COMMUNICATION ON A PCB	39
FIGURE 26	RC FILTERS ARE COMMON ON A PCB	40
FIGURE 27	BALANCING RESISTORS ARE USED FOR SPLIT DC CAPACITORS	41
FIGURE 28	<a href="#"><u>THE REOHM NTT R 150 RESISTORS ARE USED TO DAMP OVER-VOLTAGES OR TO DISSIPATE EXCESS ENERGY THAT ORIGINATES, FOR EXAMPLE, ON BRAKING OR STARTING UP</u></a>	41
FIGURE 29	THE INTERMEDIATE CIRCUIT DEMONSTRATES THE CURRENT LIMITING RESISTORS	42
FIGURE 30	IN-RUSH CURRENT DESTROYED SENSING RESISTORS OF AN PFC+LLC CHARGER	42
FIGURE 31	A RESISTOR IS USED TO IMPROVE THE POWER FACTOR	43
FIGURE 32	TEST SET-UP FOR INSERTION LOSS, CISPR 17 (A) SYMMETRICAL TEST, (B) ASYMMETRICAL TEST	44
FIGURE 33	TEST CIRCUITS FOR INSERTION LOSS MEASUREMENT, CISPR 17 (A) REFERENCE, (B) FILTER	45
FIGURE 34	REO EMC TEST	46
FIGURE 35	(A) CIRCUIT DIAGRAM AND (B) TYPICAL ATTENUATION OF A REO SINGLE PHASE MAINS FILTER	46
FIGURE 36	SIMULATION MODEL SHOWS A CLOSE-TO-MEASUREMENT ATTENUATION CURVE	47

FIGURE 37	SPECTRUM OF A 60KHZ SWITCHING EVENT WITH A RISE TIME OF 5V/NS	49
FIGURE 38	10V/NS RISE TIME SPECTRUM (BLUE) VS 5V/NS RISE TIME (GREEN)	50
FIGURE 39	REO CNW 103 THREE-PHASE FILTER GIVES GOOD ATTENUATION IN THE LOWER TO MID FREQUENCY RANGE	51
FIGURE 40	THE INPUT STAGE OF A TYPICAL INTEGRATED BUCK CONVERTER	53
FIGURE 41	(A) A <a href="#">LINE FILTER</a> MADE BY REO, (B) BEST LOCATION FOR SUCH A FILTER TO BE EFFECTIVE	55
FIGURE 42	AS CAN BE SEEN, THE WRING INSIDE THIS CABINET WAS A MESS, WITH 'FLYING' WIRES OVER THE PCB, ESPECIALLY OVER THE FILTER AREA	56
FIGURE 43	DEMONSTRATION OF A 'FLYING' WIRE OVER A POWER SUPPLY UNIT, NOISE WAS INDUCED INTO THE COAXIAL CABLE AND RADIATION OCCURRED	57
FIGURE 44	THIS LAYOUT MEANS STRONG COUPLING BETWEEN THE TWO TRACES (TRACE BEFORE AND AFTER THE FILTER)	58
FIGURE 45	FILTER POSITION IN THE CABINET, (A) INCORRECT (B) CORRECT	58
FIGURE 46	A LOW-COST FILTER IMPLEMENTATION USING FERRITE CORES AND Y-CAPACITORS	59
FIGURE 47	A DC-DC CONVERTER USED IN TESLA ELECTRIC VEHICLES, MULTI-CORES WERE CLAMPED IN THE 12V DC OUTPUT BUS BAR. THE CURRENT RATING OF THE OUTPUT COULD BE AS HIGH AS 250 AMPS	60
FIGURE 48	FRONT-END FILTERS ALSO KEEP FAST TRANSIENT NOISE FROM ENTERING THE SYSTEM	61

## List Of Symbols

C	Capacitance value
L	Inductance value

# Chapter 1

## Introduction

If you look at any electronics circuit board, you will see filters on the board. We call them filters when we see passive components such as inductors, capacitors or resistors. But there are many types of filters. For transient/surge protection, we use transient voltage suppressors (TVS) or metal-oxide varistors (MOV)s. There are also electrostatic discharge (ESD) protection devices. On some designs, there are shielding materials and electromagnetic wave absorption materials. The list can go on and on. In general, devices or circuits that protect against lightning, transient or electromagnetic interference are called filters. Here, we will only focus on the filters that are made of inductors, capacitors and resistors.

Filters only work within a certain frequency range; thus the discussion about filters is meaningless without a defined frequency spectrum. In the world of EMC, we use terms such as 'low/high frequency' and 'narrow/wide band signals'. But what do we mean when we say 'high frequency'?

The definition of low or high frequency is relative and that depends on the working frequency of the circuit under discussion. For example, a grid-tied motor drive needs to ensure that the total harmonics distortion (THD) of the unit meets regulation standards. When it comes to mains related harmonics, we use the term 'low frequency'. A modern motor drive will have a switching frequency of about tens of kHz, the EMI impact of the switching can extend to a few hundred MHz, if not GHz. We call the tens of kHz the 'low frequency range' and any frequency above 1 MHz is called 'high frequency'.

Generally speaking, the demarcation between low and high frequency is defined as follows: when the parasitic components cannot be ignored and become important enough to affect circuit operation, we are crossing the line from low frequency to high frequency [1]. This can happen from a few kHz to several GHz depending on the product. Since the frequency range from a few kHz to a few hundred MHz is critical to a wide range of electrical and electronic products, this frequency range is the primary frequency range that will be discussed in this book.



# Chapter 2

## Inductors

We all learnt the concept of inductance when we were in our high school physics class where we saw how a solenoid develops voltage where there is a change of current that goes through it.

The basic function of an inductor for a filter is to provide an in-line high impedance path (as shown in Figure 1). The impedance of an inductor increases with frequency; this is defined by Eq. 1.

$X_L = 2\pi fL$	(Eq.1)
-----------------	--------

where  $X_L$  is the impedance of the inductor,  $L$  is the inductance value and  $f$  is the frequency of concern.

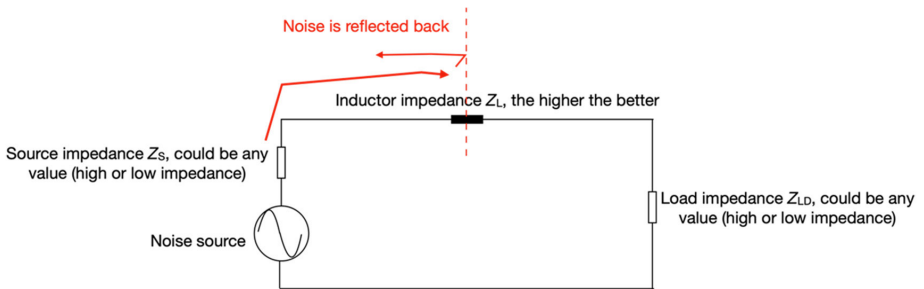

Figure 1 The function of an inductor in a filter is to provide a high impedance path

An inductor is an energy storage device, the energy stored in an inductor is given by Eq. 2.

$$E_L = 1/2 L i^2 \quad (\text{Eq.2})$$

where  $E_L$  is the total energy stored in an inductor,  $L$  is the inductance value and  $i$  is the current going through the inductor.

One misconception that engineers often have is that the energy is stored in the wires of an inductor. After all, according to Eq. 2, there must be current present in an inductor to store energy. Current is defined as a form of charge movement in the inductor (conductor), right? No, this is not true. Energy in an inductor is largely stored in the air, not in the wires. Again, Eq.2 is developed and simplified to help engineers with circuit analysis.

It does not show the fact that energy is stored in the field and the field exists predominantly in the space.

We can easily prove this by comparing the energy storage capability between an inductor without an air gap and an inductor with an air gap. We are not going to spend much time discussing this since it is beyond the scope of this work. But understanding the fact that energy is stored in the air surrounding an inductor is crucial because it helps us understand the coupling mechanism and bypassing of an inductor, which will be discussed in detail later.



*Figure 2 Understanding that energy in an inductor is stored in dielectrics such as air is important.  
Shown, [REO Edge Wound Inductor](#)*

## 2.1 - A Basic Model Of An Inductor

A basic inductor can be modelled as a circuit using the SPICE simulation tool in Figure 3. It should be noted here that we call the whole circuit an inductor, rather than the inductor symbol that we all learnt in school. This is important as, a schematic symbol provides little information on the physical structure of a component, which often limits our understanding of what is actually happening in an electromagnetic field.

A basic first-order model such as the one shown in Figure 3 cannot represent more complex phenomena such as skin effect, proximity effect and saturation. But in the frequency range of a few kHz to a few MHz, which is often the spectrum of interest for power and electronics engineers, this simplified model is often sufficient for a filter design. The important point here is that an inductor is always associated with its parasitic capacitance due to the turn-to-turn winding structure. It is only inductive until its self-resonance point (which is defined in Eq. 3 below). After the self-resonance point, an inductor behaves more like a capacitor.

$$f_{\text{res}} = 1/(2\pi\sqrt{LC}) \quad (\text{Eq.3})$$

where L is the inductance value and C is the capacitance value.

In Figure 3, L1 is the inductance value of the inductor, C1 represents the turn-to-turn winding capacitance, R1 is the inductor winding resistance, which is associated with copper loss ( $i^2R$  loss), R2 is what we call leakage resistance. You can treat R2 as a form of natural damping in the inductor.

Putting a leakage resistance in a SPICE model is important. It has been found that without the resistor in this model, sometimes the circuit that we try to simulate will not stabilise.

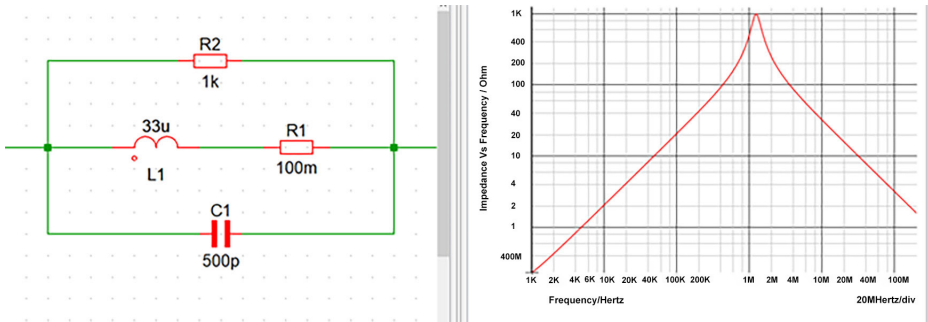

Figure 3 Basic model of an inductor and its impedance curve

As the frequency increases, not only does the parasitic capacitance become dominant, there are also skin effect and proximity effect which are associated with eddy current. Most of the time, from the EMC design perspective, both skin effect and proximity effect increase the lossy component in your inductor and reduce the leakage inductance, so that the filtering impact is affected.

The biggest factor that could significantly reduce the effectiveness of an inductor is the saturation of the magnetic core due to excessive current in the winding that is higher than the rated current. When an inductor is saturated, it loses much of its inductance value and its filtering capability is significantly compromised. Another factor that often leads to an ineffective inductor is near field coupling due to its surrounding electromagnetic environment. This will be covered in detail in the next chapter.

## 2.2 - Differential-Mode And Common-Mode Chokes

EMI is a field phenomenon, but an electromagnetic field is very difficult to imagine without 'seeing' it. We use simple terms such as voltage and current to help us understand EMI because they are more tangible. If we start talking about electric fields or magnetic fields, it often frightens people away.

Engineers are familiar with voltage and current, so it is natural that when we discuss EMC, we use terms such as radio-frequency (RF) voltage/current. This is particularly true for conducted emissions. The conducted noise can be simplified as a sum of differential-mode and common-mode noise. These noises can be measured either by a line impedance stabilisation network (LISN) (voltage measurement) or by a good bandwidth current probe (current measurement).

EMI is a field phenomenon, but an electromagnetic field is very difficult to imagine without 'seeing' it. We use simple terms such as voltage and current to help us understand EMI because they are more tangible. If we start talking about electric fields or magnetic fields, it often frightens people away.

Engineers are familiar with voltage and current, so it is natural that when we discuss EMC, we use terms such as radio-frequency (RF) voltage/current. This is particularly true for conducted emissions. The conducted noise can be simplified as a sum of differential-mode and common-mode noise. These noises can be measured either by a line impedance stabilisation network (LISN) (voltage measurement) or by a good bandwidth current probe (current measurement).

A simple buck converter is set up to demonstrate the difference between differential-mode and common-mode noise. In the schematics shown in Figure 4, the buck converter is connected to a DC power supply unit (PSU) through a LISN. The blue line shows the differential-mode current. The differential-mode current is dominant in the low frequency range (from a few kHz to about 3 MHz) and is often easy to understand. It is often associated with the switching frequency of a switched mode power supply (SMPS) or a motor drive circuit.

Common-mode noise is shown as the red lines in Figure 4. Common-mode noise is often of high frequency contents (from a few MHz to GHz). Due to its high frequency characteristics, a small value of parasitic capacitance between the converter and the ground plane can provide a low impedance path for the RF current to form a loop [2]. As the RF current travels on the surface of the cable which is connected between the converter and the power supply unit, the cable becomes a radiating antenna, which is a big source of radiated emissions. This is demonstrated in Figure 5.

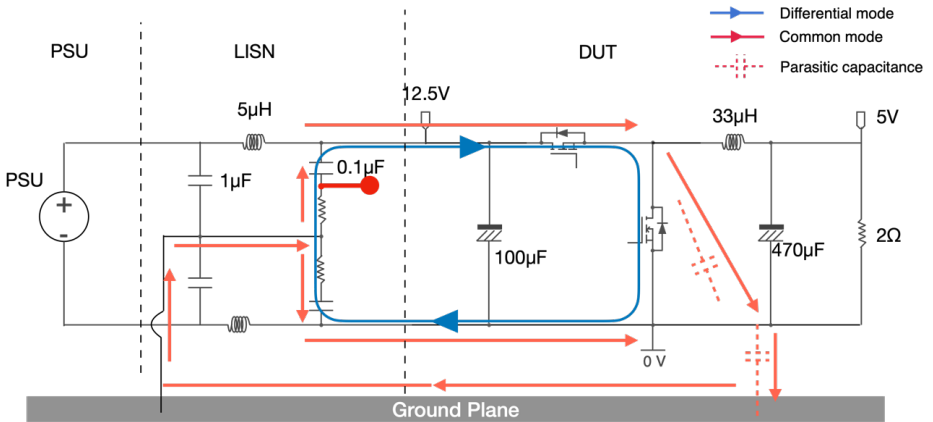

Figure 4 Demonstration of differential and common mode current loop in a SMPS

**Device under test - A buck converter**

**Cable is an antenna**

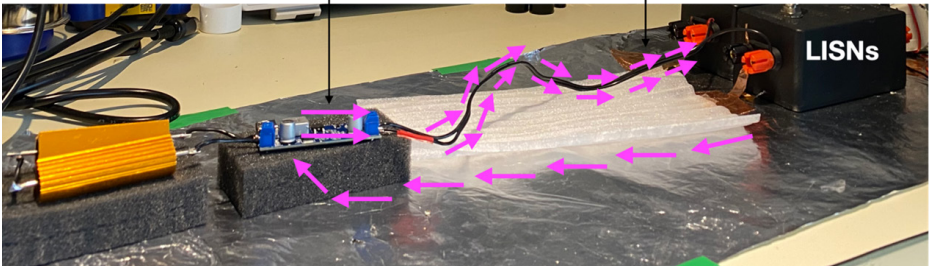

Figure 5 Common-mode current forms a loop; an antenna structure in this loop such as this cable will then radiate strongly

The same principle applies to much larger systems such as an industrial motor drive that is shown in Figure 6. The motor cables and the inverter exhibit parasitic capacitance to the ground structure (or any metal structure nearby that could serve as a return path for RF energy). Common-mode currents thus flow freely through the parasitic capacitance. As a result, a large loop is formed, which leads to both conducted and radiated emissions.

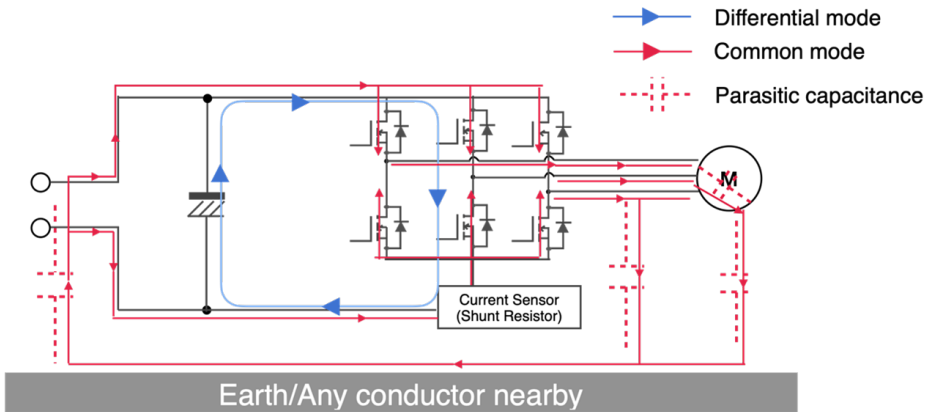

Figure 6 Demonstration of differential and common mode current loop in a SMPS

Once the concept of differential-mode and common-mode noise is understood, filters to address both types of noise can be designed. Generally speaking, an inductor is used for differential-mode noise suppression while a common-mode choke is used for common-mode noise suppression.

In applications such as a grid-tied inverter of a motor drive (see Figure 7), both differential and common-mode filters can be found. The input mains filter stage is a  $\pi$  filter while the inverter output filter is a two-stage filter that consists of a low pass L-C filter and a three-way common mode choke. Capacitors are often designed with inductors to form either an L-C or a  $\pi$  filter. Filter topologies will be discussed in the following chapters.

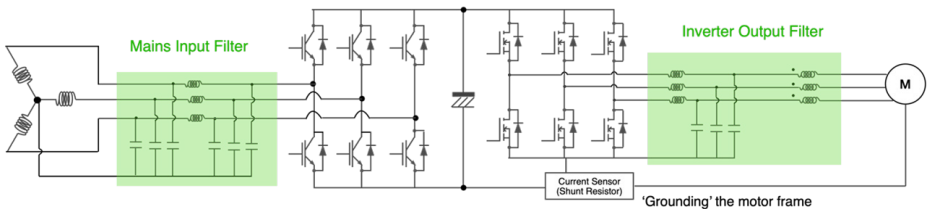

Figure 7 Filters in a typical three-phase motor drive system

The past decade has witnessed both a leap forward in technology and market expansion of the global electric vehicle (EV) industry. The electrification of the automotive industry has been advancing at a fast pace. New automotive products



need to comply with the new EMC regulations (such as ECE R10), which presents a new challenge for automotive manufacturers [3].

A typical example is an on-board charger (OBC) of an electric vehicle, which needs to comply with the harmonic requirements on the AC power lines. EMI filters of an 11 kW OBC are shown in Figure 8. As can be seen, EMI filters are designed for both the input and output stages of the converter. Considering the voltage and current rating of these parts, the OBC filters are not small. They often account for 20-40% of an OBC's form factor.

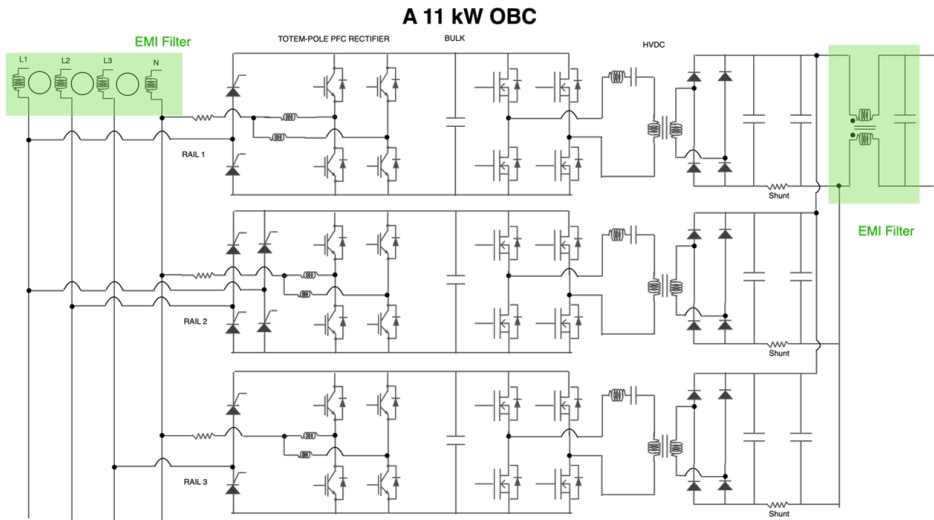

Figure 8 Simplified system diagram of an 11 kW On-Board Charger (OBC)

## 2.3 - Inductor Structures

The basic structure of an inductor is simple. Winding an enamelled wire around a magnetic core material will give you an inductor. But there are many different types of magnetic core materials such as ferrite or powdered iron. The shape of the core can be toroidal, E-shaped or many other shapes. The winding can be a single strand conductor, or multi-strand (rope-type) winding, or even a Litz wire. Engineers should select the right choice of inductor for their specific application.

For example, nanocrystalline materials have become popular for inductor/common mode choke due to their performance in the broadband spectrum. But for motor drive application or high power SMPS application, where EMI issues often start in the few kHz range, the Manganese-Zinc core is a better choice.

If you increase the number of turns of an inductor's winding, you would expect the inductance value increase. In fact, you would expect the inductance value to increase a lot since the relationship between the inductance and the number of turns is defined in Eq. 4. As can be seen, the inductance is proportional to the  $n^2$ .

$$L = n^2 A k \mu_0 \quad (\text{Eq.4})$$

where  $n$  is the number of turns of a winding,

$A$  is the cross-sectional area,

$k$  relates to the geometry of the coil of an inductor and  $\mu_0$  is the permeability of free space.

In reality, however, the inductance of an inductor does not have the proportional squared relationship with the number of turns. As the number of turns increases, so does the turn-to-turn capacitance of the winding. This will shift the resonant frequency to a lower frequency point, meaning the capacitance part of an inductor starts to dominate. In fact, this is one of the main reasons why engineers sometimes find that an inductor has little impact on a design.

A case study is presented here to demonstrate this point.

In Figure 9, a two-stage filter featuring two CMCs was designed to suppress noise in the frequency range of 20 to 30 MHz. The datasheet of the CMC suggests good attenuation in the frequency range of interest. However, when the circuit was tested, engineers found the filter did not suppress the noise as they had hoped. The CMC has a nanocrystalline core with a 'rope' type winding structure.

The first trial we made was to remove the two CMCs from the circuit and re-test the board EMC performance. To the engineers' surprise, removing the CMCs improved the noise performance in the frequency range between 20 and 30 MHz by at least 6 dB. In the lower frequency range between 150 kHz and 1 MHz, however, the noise performance worsened.

It was not a surprise that the CMCs did not work in the designed frequency range, as from 20 MHz, the winding capacitance due to the structure of this CMC dominates. In the lower frequency range, the leakage inductance of the CMC has an impact; this explains why removing the CMCs, the lower frequency EMC performance was got worse.

Changing the two CMCs to a ferrite core with fewer turns solved the problem.

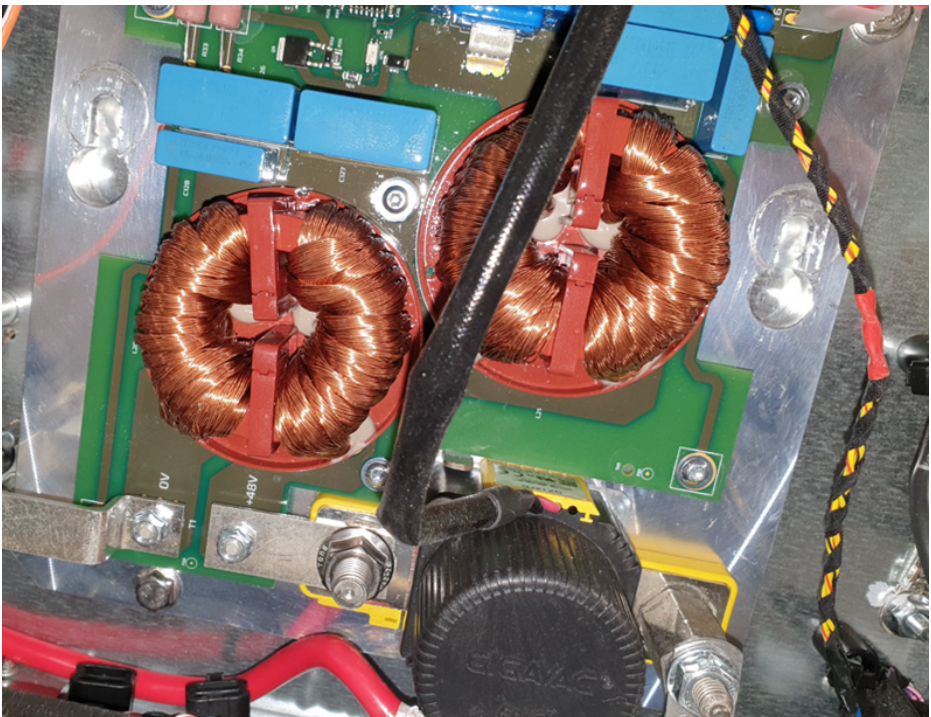

Figure 9 Two CMCs used in a two-stage filter for a DC-DC converter - [REO Type CHI131](#)

Skin effect, eddy currents and proximity effect are all related to frequency. As frequency increases, the RF current tends to travel on the very outer thin layer of a conductor, hence the name 'skin effect'. Engineers should be aware that these effects not only significantly increase the loss of an inductor, they also have an impact on the EMC performance.

For instance, eddy currents in the magnetic core increase core loss, which results in a temperature rise. The magnetic core tends to saturate with less current when the temperature increases. Eddy current and the proximity effect between adjacent layers of the winding can also lead to a reduction of leakage inductance[2].

Since inductors store a magnetic field in space, rather than in the winding or the core [5], any components nearby could then potentially couple with the field in the same space. A shielded or semi-shielded inductor is designed to contain the magnetic field, thus reducing the potential coupling. In other words, a shielded inductor has much less leakage inductance compared with a non-shielded inductor.

The importance of shielding an inductor/transformer is often overlooked by engineers. The impact of shielding can be demonstrated in the following example. In Figure 10, an inductor used in an SMPS caused conducted emission issues during the EMC test. It was found that simply shielding the inductor gave a 10 dB noise reduction. A very small change made a big difference.

### Inductor Not Shielded

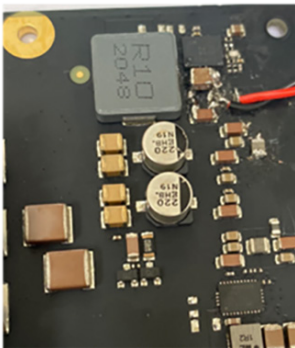

### Shielding The Inductor



(a)

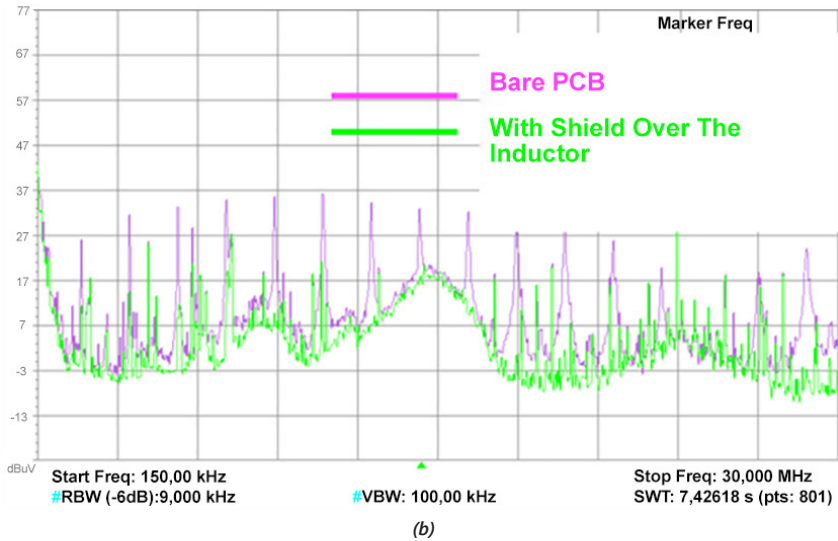
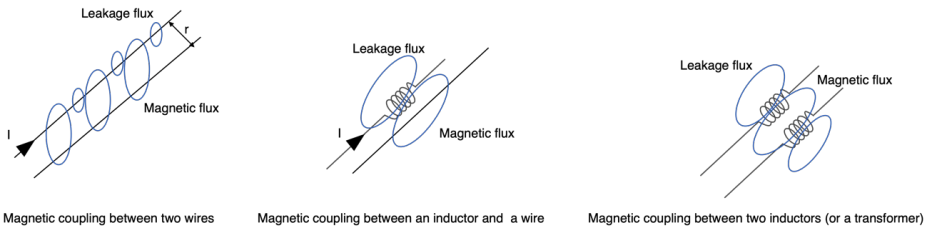

Figure 10 (a) Shielding the inductor using copper tape (b) conducted emission scan between the shielded inductor and un-shielded inductor

## 2.4 - General Layout Rules For Inductors

The number one rule of placing an inductor is to make sure that the inductor's magnetic flux is kept to a minimum, in other words, avoid magnetic-field coupling between the inductor and any other components nearby. Some common magnetic field coupling mechanisms are illustrated in Figure 11. Since magnetic field falls off at  $1/r$  (where  $r$  is the distance between the two coupling paths), keeping a good distance or using a shield is effective to prevent strong coupling.



*Figure 11 Common magnetic coupling mechanisms*

On a PCB, choosing a shielded inductor is always a safe option as we demonstrated in the previous case. If possible, the inductors that are used for filtering purposes should always be placed on the quiet side of a PCB. However, this may not be always possible due to design constraints.

In a much larger system such as an industrial motor drive, inductors should always be placed away from other cabling to avoid magnetic field coupling [6]. The filter layout rules are discussed in detail in later chapters.

# Chapter 3

## Capacitors

Capacitors are energy storage devices. Compared with an inductor, a capacitor can store energy without a continuous current flow. This is why we need to discharge a capacitor after a high voltage is removed from it, otherwise, the energy can be stored in a capacitor for a while.

The simplest form of a capacitor is two conductors separated by a dielectric material such as air. You might not realise it, but if you see a power transmission line over the earth, each cable forms a capacitance with the earth. When an aeroplane flies over, there's capacitance between the aircraft and the earth. Just look around your factory building, beams, pipes, and conduits all have capacitance between them. That's why parasitic capacitance is everywhere in the real world.

As a main energy storage device, capacitors need to be made with a high dielectric material so that they can store more energy. A discussion on the subject of capacitors could easily become a book or a dictionary.

To start with, there are different types of capacitors such as electrolytic, film, ceramic capacitors, and so on. Then, within the same type, there are different dielectric materials. There are also different classes. As for physical construction, there are two-terminal and three-terminal capacitor types. There's also an X2Y type capacitor which essentially is a pair of Y-capacitors packaged in one.

As this book is focused on filter design. We will cover the most important aspects of a capacitor.

The impedance of an ideal capacitor is defined in Eq. 5

$X_C = 1/(2\pi fC)$	(Eq.5)
---------------------	--------

where  $f$  is the frequency and  $C$  is the capacitance value.

# 3.1 - A Basic Model Of A Capacitor

A basic capacitor can be modelled as a circuit shown in Figure 11. The philosophy is pretty much the same as discussed for an inductor, where we use the circuit model to represent a capacitor. A first-order model such as this cannot represent complex behaviour of a capacitor, as the dielectric material has a nonlinearity with frequency. But for most cases, a basic model is enough to help assist a filter design.

In the case shown in Figure 12, C1 is the capacitance value, R1 represents the equivalent series resistor (ESR), and L1 is the equivalent series inductor (ESL). This particular model is simulated based on an electrolytic capacitor, which generally has a much larger ESR compared with other types of capacitors. Therefore, one can see the model itself is heavily damped by the ESR. After the self-resonant point (in this case, at about 400 kHz), the ESL starts to dominate, a capacitor starts behaving more as an inductor. The electrolytic capacitors are therefore more suitable for the low frequency range (between a few kHz and a few MHz) noise attenuation.

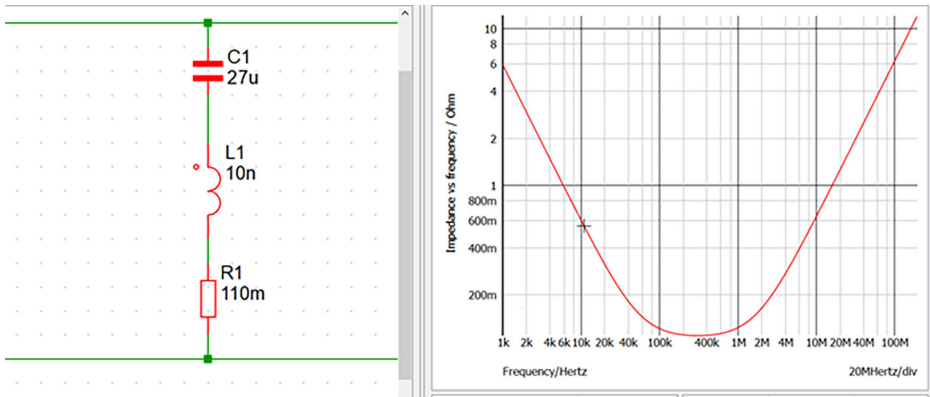

Figure 12 Basic model of a capacitor and its impedance curve



## 3.2 - Electrolytic Capacitors



*Figure 13 Electrolytic capacitors are used as a prime energy storage device*

As a prime energy source, electrolytic capacitors are mostly found in the DC link of a grid-tied inverter design or the input side of a DC-DC converter. Compared with other types of capacitors, electrolytic capacitors can achieve a relatively large capacitance value. The selection of electrolytic capacitors often depends on:

1. Capacitance value, as this often determines the very low frequency ripple of the circuit;
2. ESR and ESL, as this determines the differential-mode noise ripple on the capacitor;
3. Temperature, as it can affect the ESR of the capacitor (in this case, the higher the temperature, the lower the ESR as the ESR is a result of the chemical reaction of the capacitor);
4. Ageing is an important factor to consider, since the capacitance value can be significantly reduced due to temperature, humidity, stress, etc.; and
5. Leakage current, the leakage current also changes with age.
6. When two electrolytic capacitors are placed in series to share the voltage, balancing resistors are needed because the large tolerance of the capacitors.

From the EMC perspective, the most important feature of a capacitor is the impedance versus frequency characteristics. Low frequency conducted emissions always depend on how good the DC link capacitor is.

Here's an example to demonstrate the point. A device under test (DUT) is a high voltage (HV) electric motor used in an automotive application. One HV immunity test is the 'Burst C' test. Basically, the DUT will experience a string of very fast transients on the DC bus line (also on the V+ to vehicle chassis, and V- to vehicle chassis). The transient waveform is the same as that defined in IEC61000-4-4 (with a rise time of 5 ns and fall time of 50 ns). The DUT needs to be exposed to two burst tests, one is to test it against 5kHz with the other test to 100 kHz.

It was found that the DUT was susceptible to noise generated in the 5 kHz mode, but not the 100 kHz. Engineers were puzzled, because the pulse shape was exactly the same. By having a 100 kHz Burst, the energy injected into the system is a lot higher compared with that of a 5 kHz burst. So why is the system better at coping with the transients at 100 kHz?

The answer is the DC link capacitors. In this case, the DC link capacitors are a few 220  $\mu\text{F}$  electrolytic capacitors in parallel. Electrolytic capacitors (depending on types and manufacturers) often have a self-resonant frequency at about 100 kHz. Some well-made electrolytic capacitors can have a much higher resonant frequency point. This means the impedance of the capacitors is a lot higher at 5 kHz compared with 100 kHz. Checking the datasheet of the capacitors they used, the resonant frequency of the caps is indeed right at 100 kHz. This explains why the system has better immunity performance at 100 kHz.

Sometimes, the larger ESR of an electrolytic capacitor is not a bad thing. In certain applications, we need to have some resistive components to provide damping of the system. A typical example is presented here.

Resonance is often seen in a system that is caused by input cable inductance and the input ceramic capacitors (which generally have very small ESR value). One effective way of preventing this from happening is to add an electrolytic capacitor in between. The ESR of the electrolytic capacitor makes the system more stable. An example is simulated in Figure 14, where there is a two-meter cable between the voltage source and the circuit. We simulated two scenarios, one without the electrolytic capacitor and one with. The step response shows that the system is damped by the electrolytic capacitor.

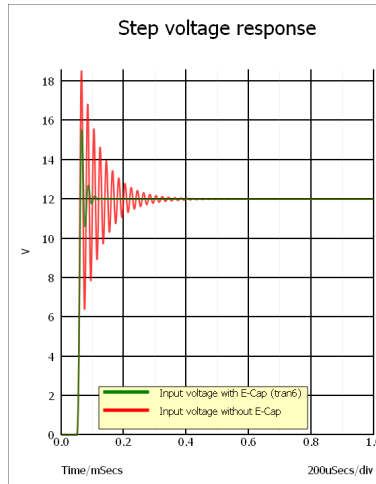
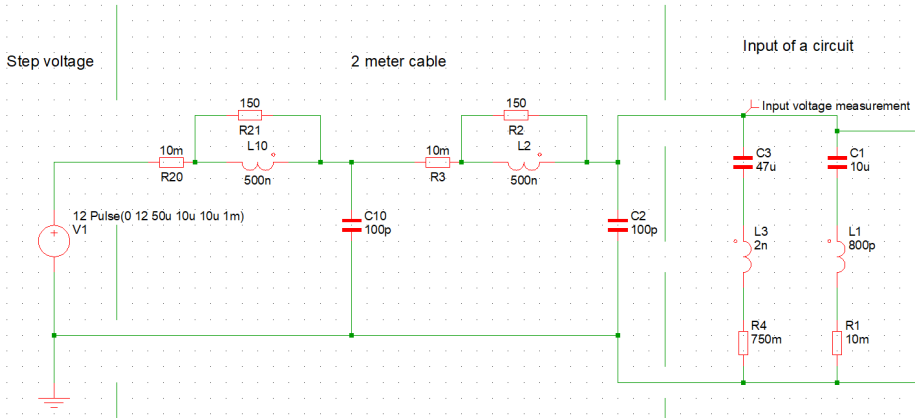

Figure 14 Simulation demonstration of an electrolytic capacitor's damping

The impedance of the DC link depends not only on the ESR and ESL of the capacitors but also on the "hot loop" area as illustrated in Figure 15. A "hot loop" is defined as

the main current loop between the energy source (in this case, the DC link capacitors) and the switching devices. A larger "hot loop" area means energy delivery takes longer, hence the circuit performance is compromised. A larger "hot loop" is also one of the biggest EMI sources as larger loops generally tend to radiate more efficiently.

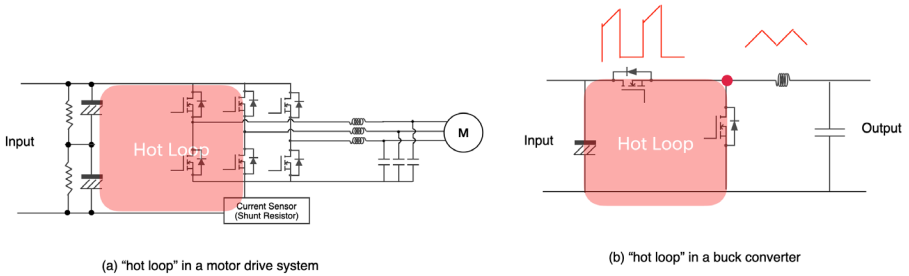

Figure 15 "hot loop" areas in the system

Reducing the "hot loop" area generally means to put the main energy source as close as possible to the switch side. One common mistake in the field is that engineers spend lots of time trying to find the lowest ESR & ESL capacitors, but layout the capacitors far away from the switches. The increased length in between means an increased ESR and ESL, defeating the very purpose of selecting a low impedance capacitor. Sometimes this is a costly lesson as we have seen designs where engineers need to replace the electrolytic with film capacitors. For the same capacitance value, film capacitors cost a lot more than electrolytic ones.

Another interesting factor of electrolytic capacitors is the extra field shielding capability obtained when the casing of the electrolytic capacitor is Aluminium. One gets the same shielding capability with Aluminium poly capacitors as well. In both cases, it has nothing to do with the capacitor dielectrics, but with the metal housing. The shielding effect is more obvious in the high frequency range where radiated emissions can be reduced by a few dB.

## 3.3 - Ceramic Capacitors



*Figure 16 Surface mount multilayer ceramic capacitors in an engineering kit*

Ceramic capacitors are small devices that can deliver energy quickly. One of the most frequently asked questions about ceramic capacitors is “What capacitance do I get when I buy a multilayer ceramic capacitor (MLCC)?” This might sound odd, but the capacitance value you get is not the one that is stated in the datasheet, as the actual capacitance value depends on tolerance, temperature coefficient, dielectric class, etc. The DC voltage that is applied on the capacitor also has a big impact on the capacitance value. It is not surprising that the effective capacitance value is only 50% of the value that is stated on the datasheet.

Perhaps another question worth asking is “How much capacitance do I need?”. The answer to this question is that for ceramic capacitors, the capacitance value shouldn't matter that much. The important consideration here is to work out at which frequency the speed of the energy delivery would be sufficient for your application. If a conducted emission failed at 100 MHz, then a capacitor that has the least impedance at 100 MHz would be a good option.

Here is another misconception of MLCCs. Engineers often spend great effort selecting a ceramic capacitor with the least ESR and ESL, only to connect the capacitor to the RF reference point via a long trace. It is worth knowing that the ESL of an MLCC is

generally much lower than the connection inductances on the board. The connection inductance remains the single most important parameter affecting the high-frequency impedance of ceramic capacitors.

An example of this poor practice is shown in Figure 17. The long trace (0.5 inch long) introduces at least 10nH inductance. The simulation result shows that the impedance of the capacitor becomes a lot higher at the frequency point (50 MHz) than is intended.

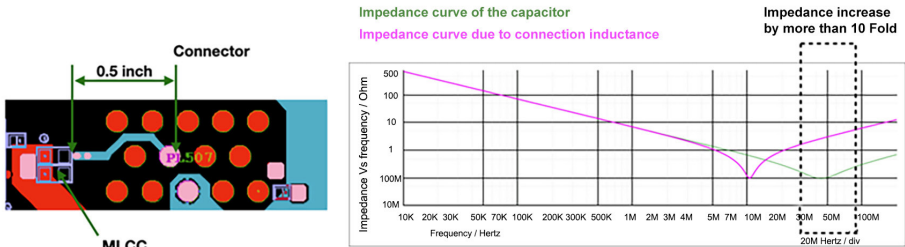

Figure 17 Long trace connection to the MLCC introduces extra inductance

Ceramic capacitors are small, surface mounted components that have very low ESR, but they also have drawbacks. One problem is that they tend to resonate a lot with the inductive structures on the board. At a frequency range above 100 MHz, even a very short trace on a PCB will have an inductance value that is large enough to form a resonant tank circuit with ceramic capacitors. Methods of damping the resonance effects include selecting capacitors that have larger ESR, or by simply putting a small value resistor (such as a one-ohm resistor) in series with the capacitor. An example is shown in Figure 18. Another way is to use another capacitance value to shift the resonance frequency either to a lower or a higher resonance point.

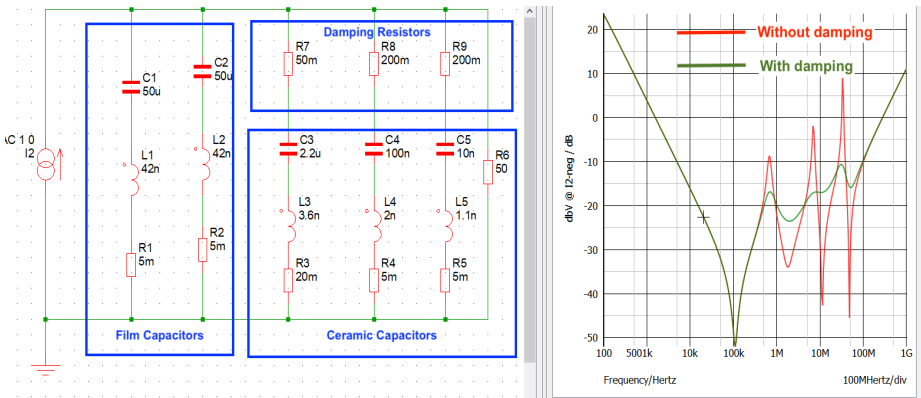

Figure 18 Resistors are used to damp the resonance caused by MLCCs

Another commonly seen ceramic capacitor type is the ceramic disc capacitor. A Y2 class ceramic disc capacitor is shown in Figure 19. They are useful for filtering the common-mode noise in home appliances, automotive and industrial applications.



Figure 19 A ceramic disc capacitor

The main functions of a Y type capacitor are EMI suppression and primary-secondary decoupling. Figure 20 demonstrates a typical use case for the Y-2 disc capacitors. Figure 21 shows the common-mode filtering performance of the capacitors. One limitation of using Y capacitors is the leakage currents, which flow along the protective earth conductor to the earth.

Since the leakage currents introduced by the Y capacitors could pose a potential safety risk, the capacitance value is limited by most product safety standards [3].

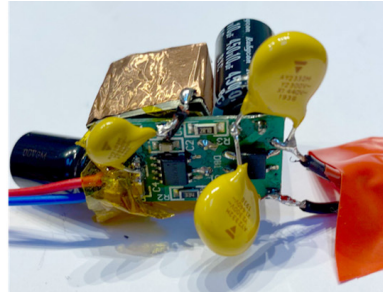
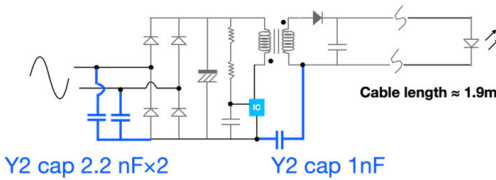

Figure 20 Ceramic disc capacitors provide EMI suppression and primary-secondary decoupling

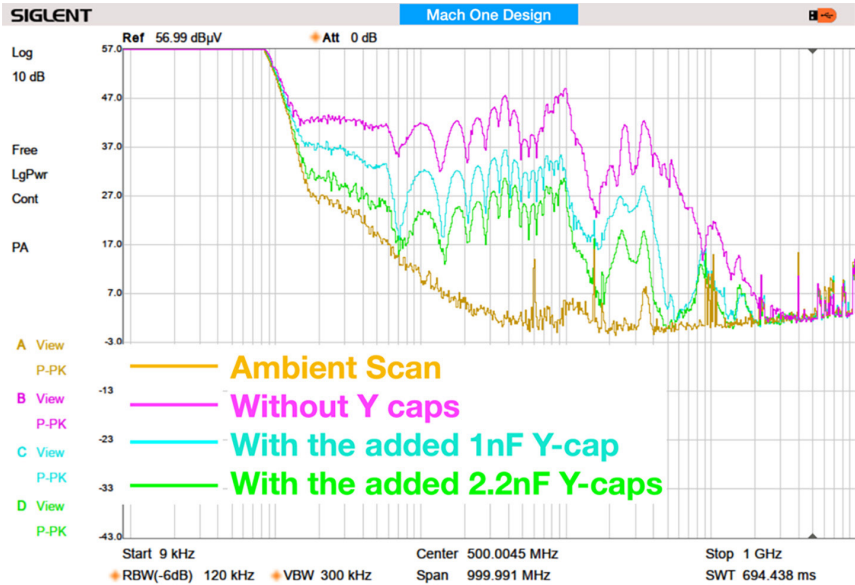
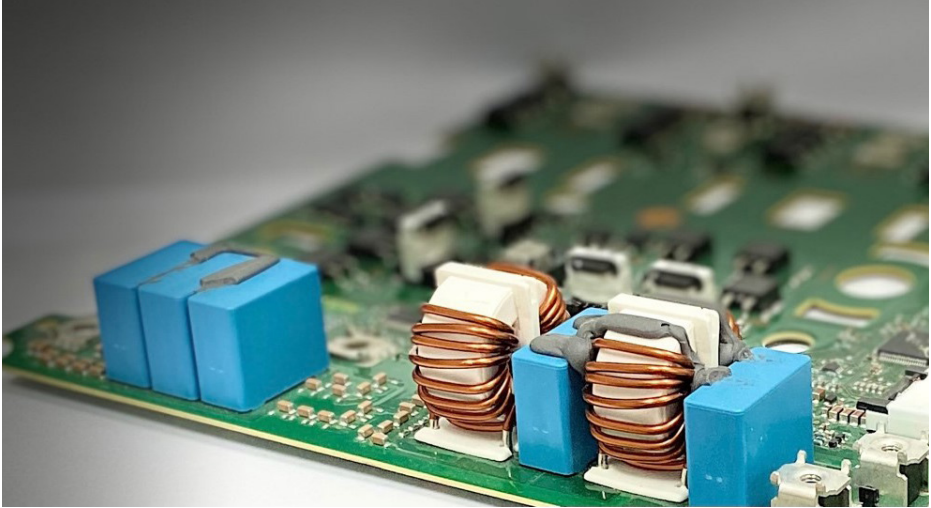

Figure 21 EMI improvement with added Y-caps



## 3.4 - Film Capacitors



*Figure 22 Film caps (in this case, X-type) are used in applications such as DC-DC converters*

Film capacitors are used in many applications. They are the capacitors of choice for high power DC-DC converters and are used as EMI suppression filters across the supply lines (both AC and DC), as well as in common-mode filtering configurations. We use an X capacitor as an example to demonstrate some of the key points of using film capacitors.

Generally, an X capacitor performs the following functions:

1. Attenuates the conducted noise directly from any switching events on the lines (for instance, a Triac device switching the mains AC line);
2. Together with an inductor, it forms a low pass filter for differential mode noise appearing on the lines; and
3. It helps limit the peak voltage stress on the lines if there is a surge event, so it is often used together with a transient voltage suppressor (TVS) or metal oxide varistor (MOV).

## 3.5 - Capacitance Degradation Due To Ageing And The Environment

An X capacitor can lose its value significantly over years of service. This is particularly true if the capacitor is used in a humid environment. There have been cases where an X capacitor's capacitance value dropped to only a few percentages of its rated value in a year or two. So the system initially designed with an X capacitor effectively lost all the protections that a front-end capacitor could have.

So, what has been happening? Damp air can leak into the capacitor, up the wires, and between the box and the epoxy potting compound. The aluminium metallization can then oxidize. Aluminium oxide is a good electrical insulator, thereby reducing the capacitance. That's one problem all film capacitors can have. The film thickness during the capacitor manufacturing process thus becomes very important. Reputable capacitor brands use a thicker film, resulting in a larger capacitor than other brands.

An X capacitor can lose its value significantly over years of service. This is particularly true if the capacitor is used in a humid environment. There have been cases where an X capacitor's capacitance value dropped to only a few percentages of its rated value in a year or two. So the system initially designed with an X capacitor effectively lost all the protections that a front-end capacitor could have.

So, what has been happening? Damp air can leak into the capacitor, up the wires, and between the box and the epoxy potting compound. The aluminium metallization can then oxidize. Aluminium oxide is a good electrical insulator, thereby reducing the capacitance. That's one problem all film capacitors can have. The film thickness during the capacitor manufacturing process thus becomes very important. Reputable capacitor brands use a thicker film, resulting in a larger capacitor than other brands. The thinner film makes the capacitor less robust to overload (voltage, current, or temperature) and less likely to self-heal as well.

If the X capacitor is not permanently connected to the supply, then there is less concern. For instance, for a product that has a hard switch between the mains and the capacitor, size is probably more important than lifetime and you can then choose a thinner capacitor. However, if the capacitor is permanently connected to the supply, then it must be highly reliable. Oxidation of capacitors is not inevitable. If the capacitor epoxy material is of good quality and the capacitor is not routinely exposed to temperature extremes, value degradation should be minimal.

## 3.6 - General Layout Rules For Capacitors

Since capacitors store and provide energy per load demand, the general rules of arranging capacitors are:

1. Capacitors should be located close to the switch and load, as this limits the 'hot loop' area.
2. If possible, use multiple capacitors in parallel rather than using a single large capacitor, as parallel capacitors effectively reduce the ESL and ESR. In this way, the energy can be supplied to the load more quickly.
3. When having ceramic capacitors, it is a good idea to use several capacitor sizes so that the energy is available over a wide frequency spectrum. It is even better to locate the smaller valued capacitors near the active components requiring decoupling.

More capacitor layout techniques are discussed later in further detail.

# Chapter 4

## Ferrite Cores



*Figure 23 Ferrite cores for round cables*

Ferrite materials such as Manganese-Zinc (MnZn) or Nickel-zinc (NiZn) are often found in the core material of an inductor. They are also popular materials for a range of inductive (and resistive) components called ferrite cores (as shown in Figure 23). Ferrite cores are extremely useful in suppressing RF noise on cables. During the product development stage, they are often used for quick troubleshooting and problem fixing. For a product that is close to the market launch deadline where iteration of the board design is no longer feasible, putting a ferrite core on cables sometimes is the only cost-effective way of getting the product to pass the EMC limit.

Ferrite cores can be used on a single wire (as a differential-mode impedance) or a bundle of wires (as a common-mode impedance). A single-turn feedthrough configuration sometimes provides sufficient attenuation on the line. But most of the time, one might need to put multiple turns of a cable through a ferrite core so as to increase the impedance, as the impedance (inductance) value of a ferrite core is proportional to the square of the number of turns.

Engineers should be aware that although the core materials are often the same,

different cores work in different frequency ranges depending on the manufacturing of these cores. Manufacturers often have specific cores for a specific frequency range. Make sure to use the right cores for the right job. For instance, if it is the medium frequency range noise between a few MHz and 30 MHz that needs to be suppressed, it is recommended to find a ferrite core whose impedance peaks in this frequency range.

Figure 24 demonstrates ferrite cores on a cable (DC side) inside the cabinet of a three-phase uninterruptible power supply (UPS) system. In this case, the noise level between 10 MHz and 30 MHz is quite high in the system, therefore a 31 material that works best in the same frequency range is selected to suppress the noise.



(a) Ferrite cores on cables in the cabinet of a product

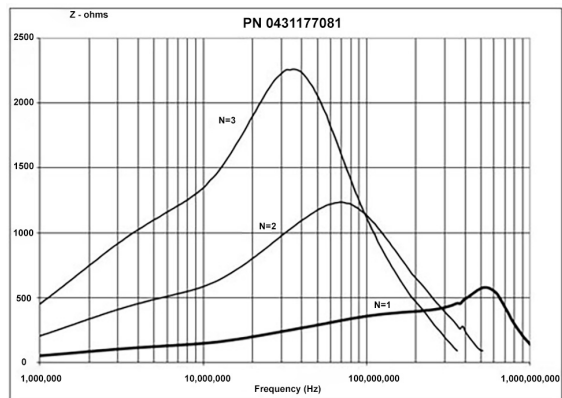

(b) Impedance vs frequency of the ferrite cores being used; Courtesy of fair-rite.com

Figure 24 Demonstration of using ferrite cores on cables

There are a few issues with multiple-turn configuration of a ferrite core:

1. As the number of turns increases, so is the turn-to-turn capacitance. While this is not a problem at lower frequency, it does have an impact at high frequency. As it is shown in Figure 24 (b), above 40 MHz, the impedance of the 3-turn configuration starts dropping. In fact, over 200 MHz, the impedance of a 3-turn configuration is lower than that of the 1-turn configuration.
2. In applications such as automotive or aerospace products, using multiple turn ferrite cores are often not allowed because of the limit of the bending radius of a cable.

In [4], secondary effects, including capacitance, leakage resistance and saturation were discussed. It showed that by placing a ferrite next to a grounded metal (such as chassis), an R-L-C filter is formed which uses the ferrite both as a resistive inductor and a distributed capacitor. This also leads to the question of the best location of placing a ferrite core. It has been found that ferrite cores have the greatest effect where the RF current on the cable is largest [5]. Therefore, positioning a ferrite core adjacent to a low-impedance connection, for example, the cable entry point of a chassis, is a good approach. There are rare situations, when placing a ferrite core could lead to increased emissions at certain frequency [6].

In such scenario, the most practical approach is to try positioning the cores in a few locations and compare the results.

Although ferrite cores are useful for suppressing the RF noise on the cable, they cannot replace a properly designed inductor. In environments where vibration and shocks are prevalent, ferrite cores need to be secured by cable ties or other means. In general, a well-designed inductor is preferred. Ferrite cores are useful as a last resort in the design and development stage or when the production volume of the products is very small.

# Chapter 5

## Resistors

Typically, filters are designed using inductors and capacitors because their impedance changes with frequency. An ideal resistor has a fixed resistance value against frequency, so it might sound odd to use resistors in a filter as they introduce  $i^2R$  loss. But resistors are prevalent for filtering purposes. The application of resistors as summarised as follows:

1. On a PCB, for signal integrity purposes, resistors are used as series and/or parallel terminations to a transmission line (as shown in Figure 25).

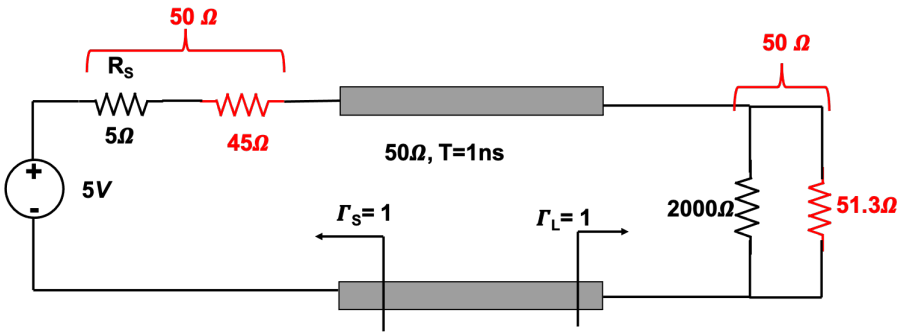

(a) Series and parallel termination

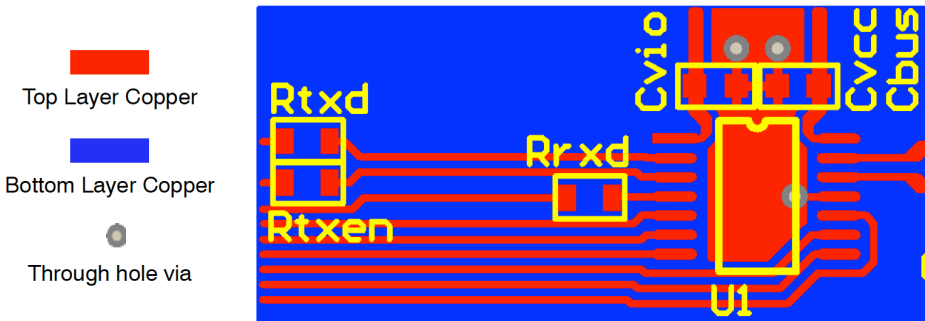

(b) Series termination on a PCB

Figure 25 Resistors are used to match the impedance of a transmission line system, which is critical for high speed data communication on a PCB

- To damp the resonance in a system, resistors are connected in series with a capacitor or in parallel with an inductor. The reasoning for this was covered in previous discussions.
- R-C filters are often used for applications where the phase shift of the signal needs to be minimised. For example, in motor drive applications, the phase current often needs to be sampled for controlling the motor. This is usually done by having a shunt resistor in phase with the bridge side switches. Since the motor rotates at a fast speed, the delay of the sampling signal needs to be minimised. In such an application, an R-C filter rather than an L-C filter is often preferred after the shunt resistor. R-C filters are also very common in the peripherals of a microcontroller chip such as Analog to Digital Converter (ADC).

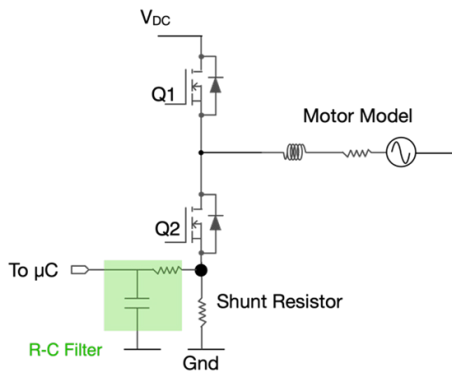
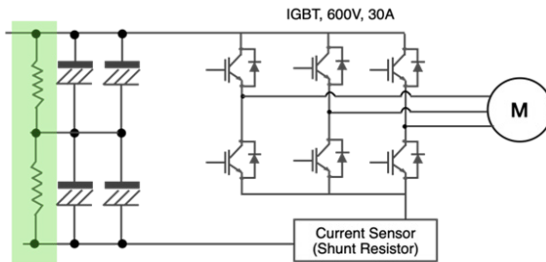

Figure 26 RC filters are common on a PCB

- In a high voltage system, in order to withstand the voltage on the DC link, sometimes two capacitors are connected in series. If the two capacitors are the electrolytic type, they are subject to a higher level of leakage current (compared with film type capacitors). Also due to the capacitance tolerance, it is important to balance the two capacitors using balancing resistors. Balancing resistors make sure the voltage sharing between the two capacitors are the same, and they also provide the 'bleed' function when the capacitors discharge. They are essential for preventing the electrolytic capacitors from ageing prematurely.





### Balancing resistors



Figure 27 Balancing resistors are used for split DC capacitors

- In a high voltage, high-power system, damping resistors are used to absorb and temporarily store higher impulse loads



Figure 28 The REO R 150 resistors are used to damp over-voltages or to dissipate excess energy that originates, for example, on braking or starting up

- Resistors are used as current-limiting components to prevent in-rush current or used as 'bleed' resistors for capacitors (as shown in Figure 29). In-rush current, often caused by low impedance in the line during power up, can cause damage to the board. Figure 30 Shows an PFC+LLC charger that suffered from an in-rush current incident, the weak points in the system are the sensing resistors, which were completely destroyed during the incident.

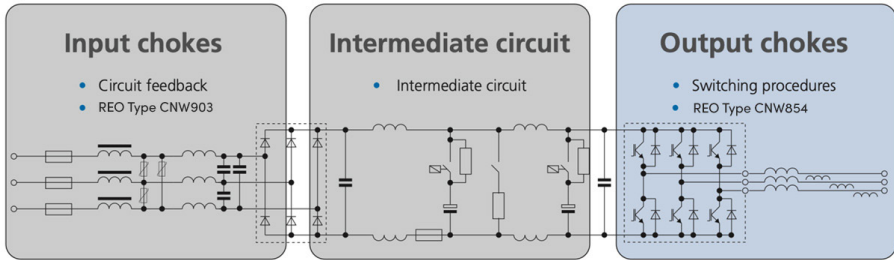

Figure 29 The intermediate circuit demonstrates the current-limiting resistors

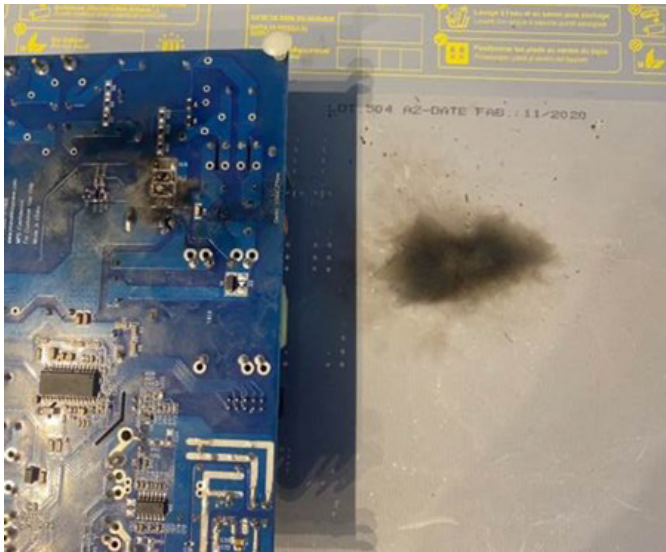

Figure 30 In-rush current destroyed sensing resistors of an PFC+LLC charger

7. In some applications, resistive components are used in the front-end of a power system to improve the power factor, mains harmonics and crest factor. Compared with inductors, resistors don't have any phase shift, ideal for power factor correction. They also allow the circuit to withstand supply voltage surges without needing a varistor. The drawback of using a resistor is that they lower the overall system efficiency.

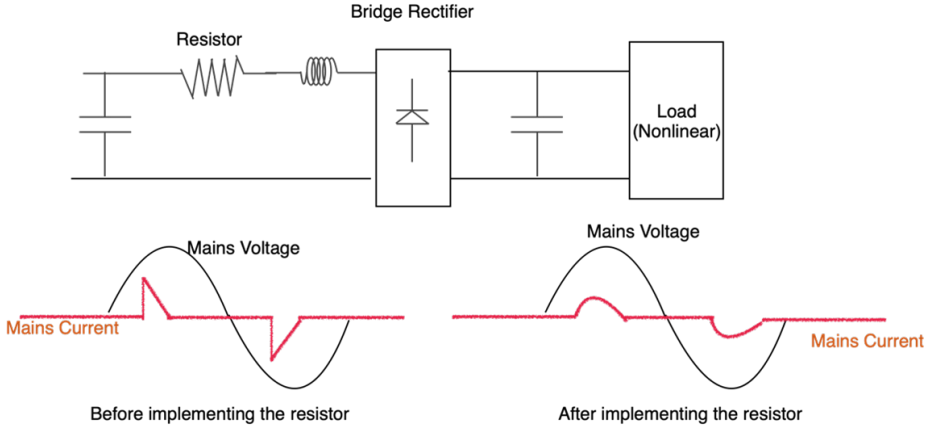

Figure 31 A resistor is used to improve the power factor

# Chapter 6

## Filter Design

### 6.1 - Insertion Loss

Filters are almost always a part of an electronics design. Design engineers design a filter to achieve certain attenuation in a specified frequency range. We have seen that with inductive components, the impedance increases with frequency while the capacitors' impedance decreases with frequency. By combining inductors and capacitors, we can build many types of filters, such as high-pass, low-pass or band-pass. Popular filter configurations include L-C, C-L-C ( $\pi$ ) or L-C-L (T).

The performance of a filter is measured in terms of attenuation, or insertion loss, both of which use the units of decibels (dB). The best place to start this discussion is CISPR 17, which defines the technical terms of a filter. It also presents a detailed explanation of how to measure the insertion loss of a filter.

A filter often provides attenuation to noise in both differential mode and common mode. At a low frequency range (often between a few kHz and 1 MHz), noise is predominantly a differential mode mechanism. When the frequency goes up, common mode noise becomes more dominant.

Take a  $50\Omega/50\Omega$  (source impedance/load impedance) system for instance, CISPR 17 defines two tests to measure the filter performance, which are symmetrical (differential mode) and asymmetrical (common mode). The test set-ups are shown in Figure 32. The signal generator (G) performs a signal sweep between the defined frequency range. The voltage across the load ( $Z_2$ ) is measured during the sweep.

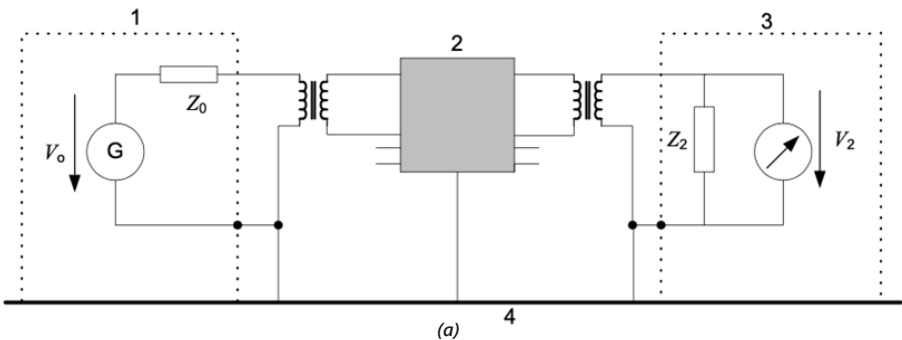

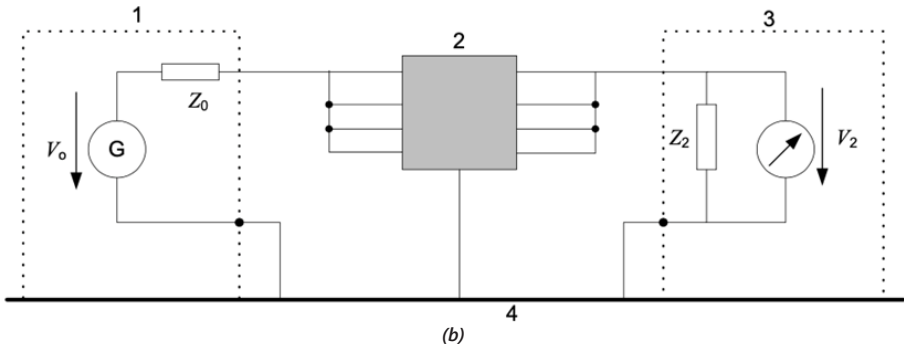

Figure 32 Test set-up for insertion loss, CISPR 17 (a) symmetrical test, (b) asymmetrical test

Note that in both cases  $Z_0$  and  $Z_2$  are  $50\ \Omega$ . In reality, a  $50\ \Omega/50\ \Omega$  system rarely exists. Therefore, the worst-case test set-ups, such as  $0.1\ \Omega/100\ \Omega$  and  $100\ \Omega/0.1\ \Omega$  give better filter performance analysis.

The insertion loss is defined as

$$\text{Insertion Loss} = 20\log(V_{20}/V_2) \quad (\text{Eq.6})$$

Where  $V_{20}$  is the voltage across  $Z_2$  before the filter is inserted, and  $V_2$  is the voltage measurement after the filter is inserted, as per Figure 33.

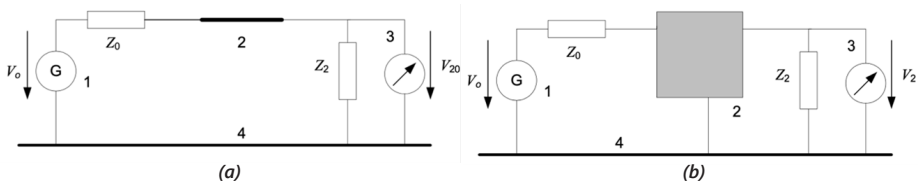

Figure 33 Test circuits for insertion loss measurement, CISPR 17 (a) reference, (b) filter

While it sounds easy and straight forward, engineers often need to see the test set-up to understand the concept better. Figure 34 shows the test set-up of an REO filter according to CISPR 17. The circuit diagram of the filter being tested is shown in Figure 35(a) and the insertion loss curve is shown in Figure 35(b).

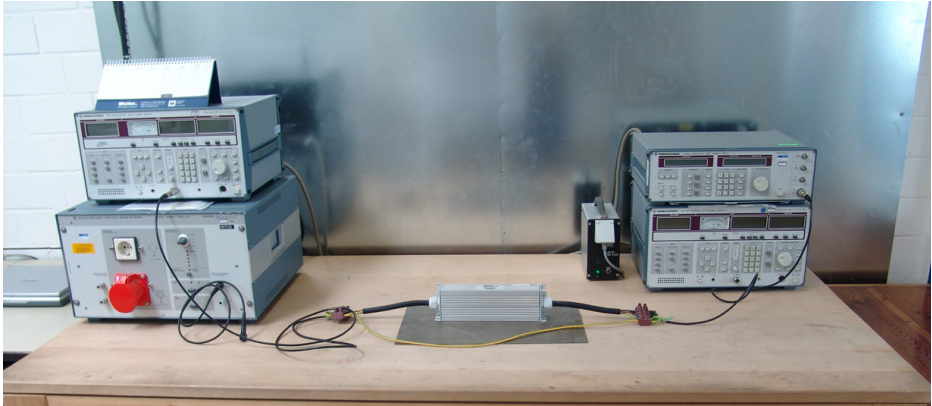

Figure 34 REO EMC Test

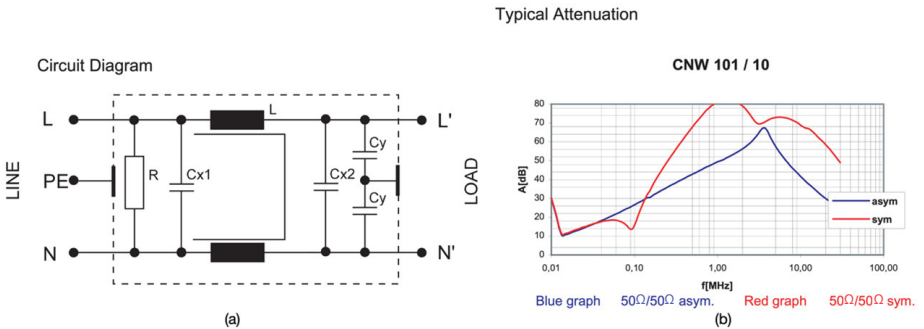

Figure 35 (a) Circuit diagram and (b) typical attenuation of a REO single phase mains filter

A simulated filter model is built in the SPICE simulation tool and the circuit can be found in Figure 36. As shown, when introducing parasitics into the simulation model, a close to real measurement result can be achieved. To build a useful simulation model, especially before the filter is implemented, engineers need to understand the parasitics of each passive component in the filter. If the passive components are arranged so that coupling occurs, engineers should also be aware that the filter

performance could be compromised by coupling. If an off-the-shelf filter is purchased, it is a good idea to always ask the filter manufacturer for a measured attenuation curve such as the one shown in Figure 35.

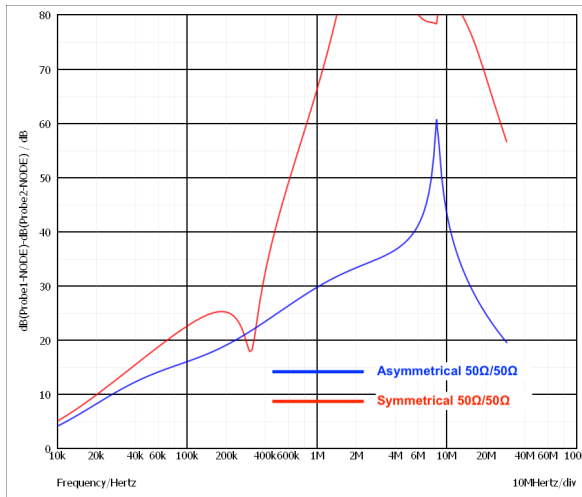
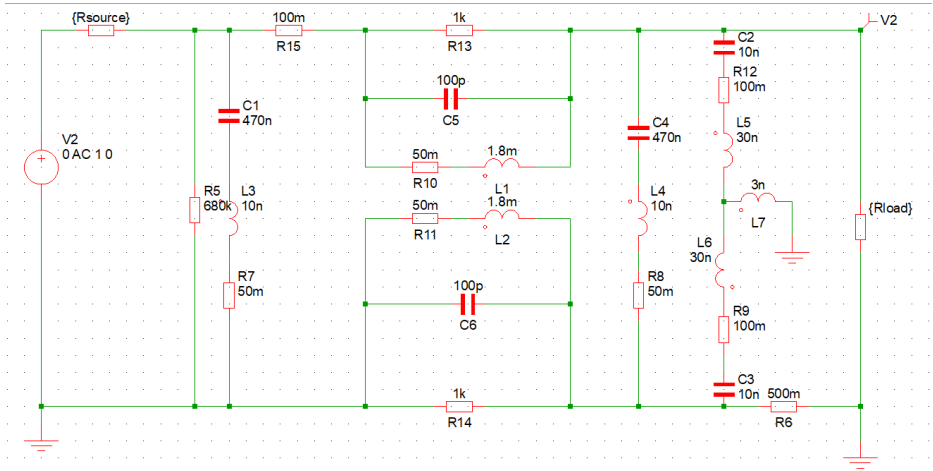

Figure 36 Simulation model shows a close-to-measurement attenuation curve

## 6.2 - Design Filters With Simulation

Most of the noise that engineers come across in the field is generated by high-frequency, fast switching devices. Typical examples are motor drive inverters, DC-DC converters, power supplies, microcontrollers and communication chips. Therefore, filters are often designed to suppress the noise caused by switching events.

In the past, IGBTs and MOSFETs were the main switches. MOSFETs were predominantly used in low voltage applications while IGBTs were used in medium voltage applications. When the voltage is above 800V, IGCTs and GTOs are the devices of choice. MOSFETs can be switched rather quickly, but they are limited by the voltage rating and their thermal properties, therefore, typically they are limited to about 150kHz switching frequency and the rise time is often found to be from a few nanoseconds to 10s of nanoseconds. IGBTs have a tail-current, which limits their switching speed and switching frequency. Typically, the switching frequency of an IGBT based system is limited to about 60kHz.

This will soon change as the newly developed wide-band-gap (WBG) devices such as Silicon-carbide (SiC) and Gallium-nitride (GaN) devices show superior performance over the MOSFETs and IGBTs. The fact that they can switch faster at higher voltage means the  $dV/dt$  of WBG devices is a lot higher. This inevitably leads to more EMI.

There are two aspects of a switching event, the switching frequency and the switching speed. When talking about EMI associated with the switching events, many engineers often focus on the switching frequency and overlook the impact of switching speed. The switching speed should have more attention paid to as it is the main EMI source. It is not necessary to have a high switching frequency to cause EMI problems. Consider this example; an electrostatic discharge (ESD) event does not have MHz of switching frequency, but the rise time is as short as 10s-100s of picoseconds. One ESD event could potentially radiate the energy to a nearby system and cause trouble.

A switching event is simulated in the SPICE simulation software. The simulated switching event has a 60kHz switching frequency, with 600V DC voltage, and the duty ratio in this case is 50%. The rise time is set as 12 ns to give a 5V/ns switching speed. Spectrum analysis of the switching event is shown in Figure 37.



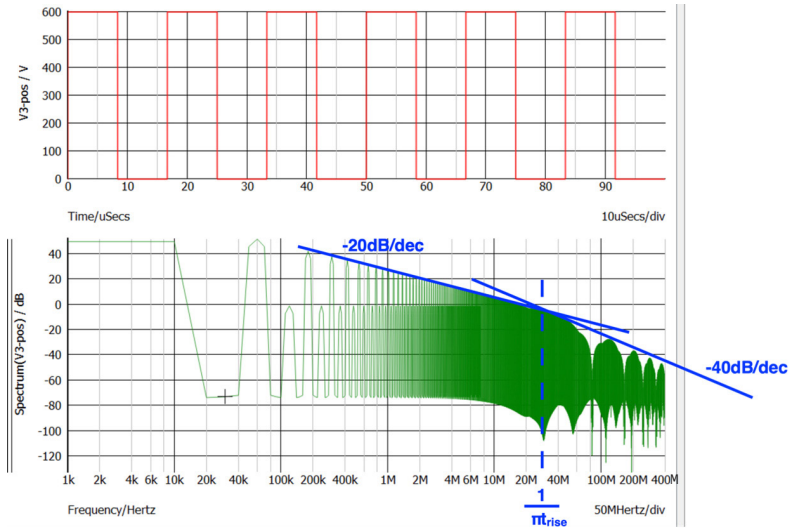

Figure 37 Spectrum of a 60kHz switching event with a rise time of 5V/ns

Notice that the -20dB/decade line and the -40dB/decade line crosses at the frequency point of  $1/\pi t_{rise}$ , which in this case is calculated to be 26.5MHz. Ideally, one would like the -40dB/decade roll off to occur at a lower frequency point, because the noise spectrum decreases a lot faster after this crossing point. But the roll off point only depends on the rise time of a switching event.

Engineers often don't have the option of shifting this point. This is because the rise time of a switching event often cannot be increased as increased rise time leads to more switching loss and less system efficiency.

To demonstrate the effect of sharp rise time, in Figure 38, a faster rise time (10V/ns) is simulated for comparison. As it can be seen, every time the switching speed is doubled, it results in a 3-6dB noise increase from  $1/\pi t_{rise}$ .

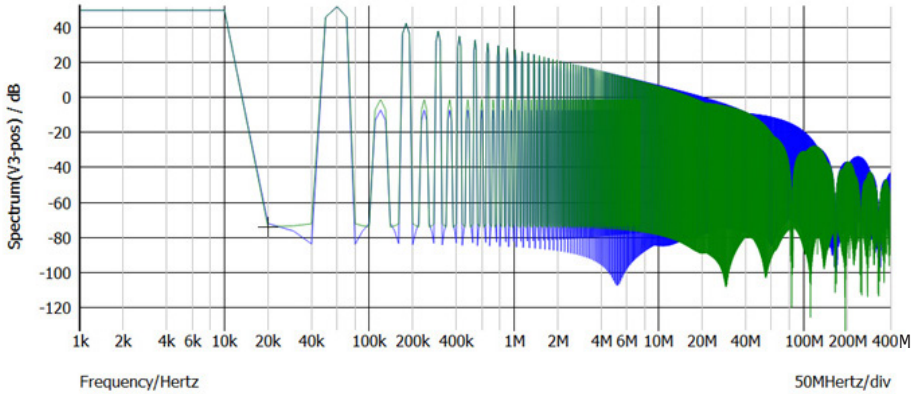
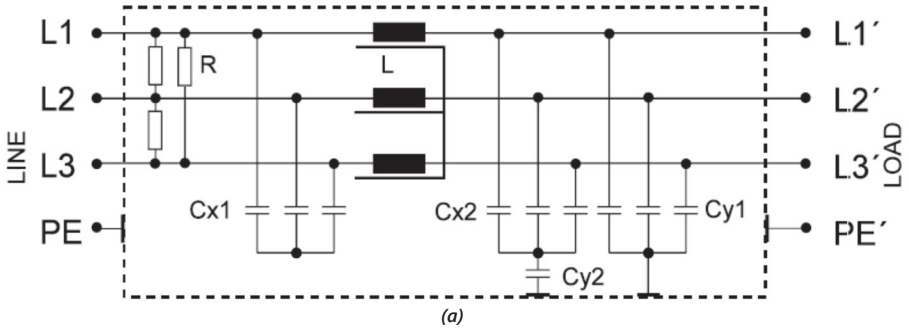

Figure 38 10V/ns rise time spectrum (blue) vs 5V/ns rise time (green)

Once the spectrum characteristics of a switching event are understood, it is then easy to design a filter that aims to suppress the noise at the frequency range of interests.

For instance, a motor drive causes conducted emission between 100 kHz to 10 MHz, the lower frequency range noise (<1MHz) often needs differential mode filtering, whereas, between 1MHz and 10 MHz, some form of common-mode filtering is needed. A three-phase filter that has sufficient attenuation in this range would be a good choice. One example is a C-L-C ( $\pi$ ) filter, which is shown in Figure 39.

Circuit Diagram



Typical Attenuation

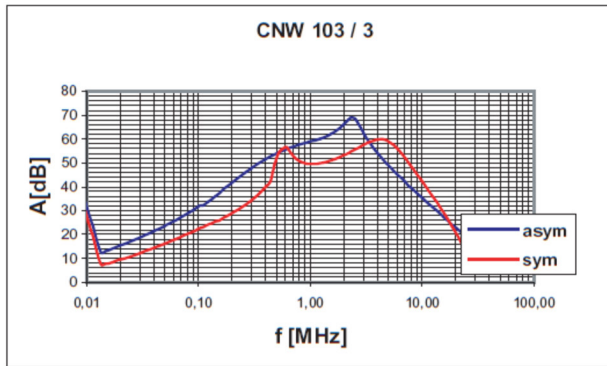

Blue graph 50Ω/50Ω asym. Red graph 50Ω/50Ω sym.

(b)

Figure 39 REO CNW 103 three-phase filter gives good attenuation in the lower to mid frequency range

## 6.3 - Mode Conversion

In the previous discussion, differential and common mode noise were discussed. Inductors and X class capacitors are generally used for differential mode noise suppression while common mode choke and Y class capacitors are found in common mode noise filtering.

In reality, it is impossible to differentiate differential and common mode noise completely. A mechanism called DM-to-CM mode conversion occurs when there is unbalance in the impedance of the filter components.

A typical mode conversion happens when incoming RF or transient interference currents are generated in common mode and convert to differential mode due to differing impedances at the cable interfaces, or within the circuit [4]. At high frequency, the common mode attenuation of a filter is often effective, but at lower frequencies, the mode conversion often means the noise cannot be rejected by the input common mode filter.

Another example of mode conversion is demonstrated in [7] where a ribbon cable with a return plane under the signal wires has largely unbalanced impedance, resulting in very little common mode voltage.

Mode conversion means that a well-designed filter should consist of both differential and common mode suppression.

# Chapter 7

## Filter Layout

### 7.1 - Location

Here is a classic question; - where should we put the filter with regard to the noise source? Shall we place the filter close to the noise source or away from it? The answer is; - if you can, you should always place the filter in a quiet environment, i.e. away from the noise source.

Here we should not get confused with what we say about 'solving EMI problems at the noise source'. We all know that the best approach to solving EMI problems is to suppress the noise source. Without understanding the principles, engineers often put an EMI filter close to the noise side, such as a SMPS on a PCB, or a line filter close to a motor drive circuit. This creates problems because the strong leakage field of the noise source will couple strongly with the passive components of a filter. As a result, a carefully designed filter, which is supposed to give 60-80 dB attenuation according to the simulation/calculation, often ends up having only 10-20 dB insertion loss. This is particularly true when the frequency increases.

The circuit shown in Figure 40 is given to demonstrate the point. The input stage of a typical buck converter using an integrated switching IC is shown. On the input side, the filter stage is separated from the input capacitors by including the red dashed line. Note that there can never be a strict separation line between the filter and the input capacitors as the input capacitors also provide a low impedance path to noise, so they work nicely with the filter. But here the two are separated to make the point

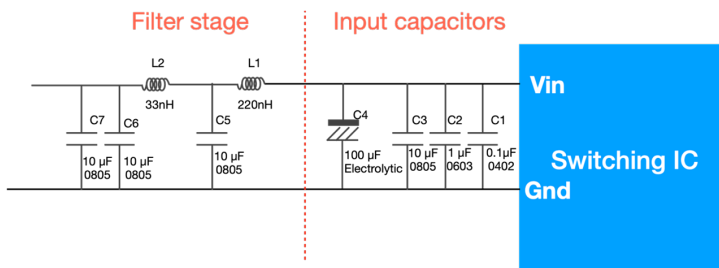

Figure 40 The input stage of a typical integrated buck converter

The input capacitors are part of the SMPS design. Therefore, one will need to design the capacitors to make sure there is always enough energy delivered in the most efficient way whenever the switch is turned on. This is often achieved by the following:

1. Populate the input supply rail with several decoupling capacitor sizes (0402, 0603, 0805, etc) so that energy is available over a wide frequency spectrum.
2. The decoupling capacitors should be connected as close as possible to the Vin pin.
3. Locate the smallest size capacitor (in this case C1, 0402) first to the Vin pin.
4. The electrolytic capacitor C4 serves as the main energy storage device, but it also provides damping of the system due to its relatively larger ESR.
5. If the electrolytic capacitor has a metal housing, such as aluminium, due to the larger size of the electrolytic capacitor, the metal housing also serves as a shield to block some of the electric field created by the SMPS.

The filter stage is designed as a multi-stage filter which consists of two inductors and a few ceramic capacitors. The red line shown in Figure 40 indicates that there must be a distance between the filter and the input capacitors. This is to avoid field coupling and make the input filter stage more effective. On a PCB level, this is often achieved through the following steps:

1. Put the input filter away from the noise source, if the noise source is a SMPS and it is located on one side of the PCB, the safe side of a filter should be on the opposite side of a PCB.
2. If the filter stage has to be on the same side of the SMPS, a physically long distance shall be kept. The distance depends on the strength of the leakage field of the SMPS. For instance, if the switch node of the SMPS is kept quiet by a shield, then the distance between the filter and SMPS can be shortened.
3. The connection between the filter stage and the input capacitors should always be a high impedance path such as an inductor (L1 shown in Figure 40).

The same principle applies to much larger systems such as an industrial motor drive system or power supply. For instance, a line filter used for an industrial motor drive application such as the one shown in Figure 41 (a) is always much more effective if it is placed near the mains entry point of the cabinet, i.e. to keep the mains wiring and the line filter far away from other wiring and harnessing inside the cabinet. Again, the reason is to avoid close field coupling between the noise source and the filter component.

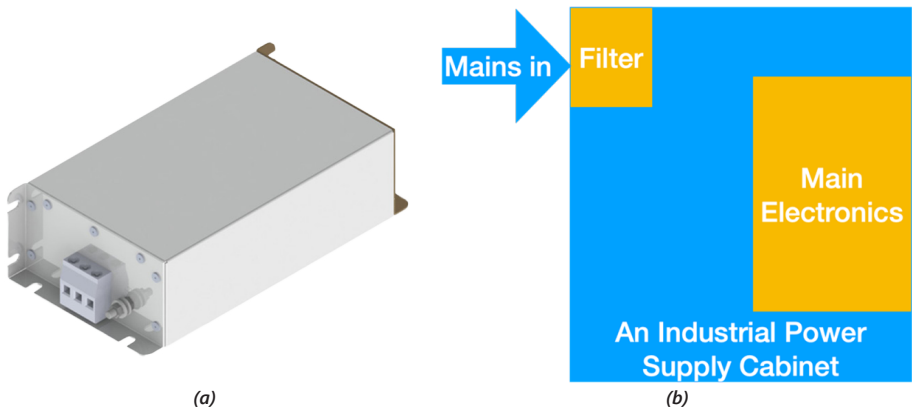

Figure 41 (a) a line filter made by REO, (b) best location for such a filter to be effective

## 7.2 - Common Mistakes And How To Avoid Them

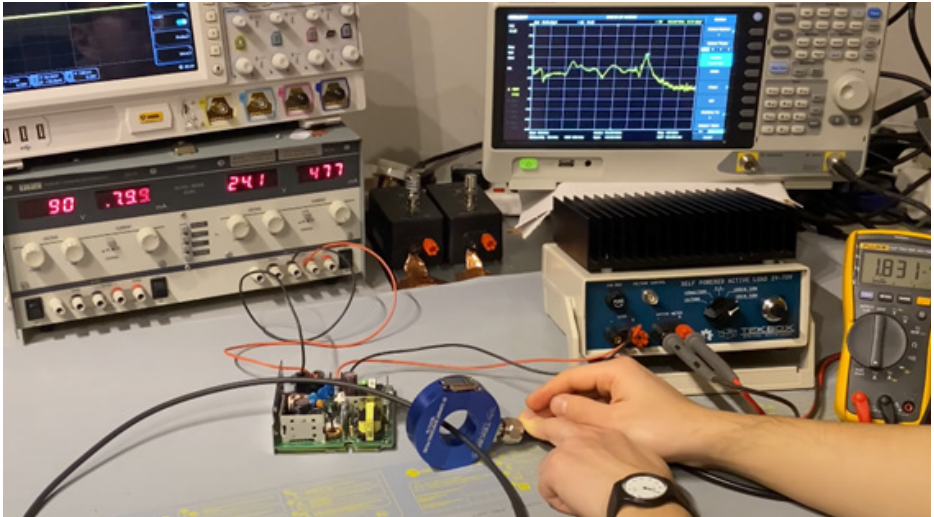

*Figure 42 As can be seen, the wiring inside this cabinet was a mess, with 'flying' wires over the PCB, especially over the filter area*

One of the common mistakes that could lead to in-effective filters are 'flying' wires over the filter, as it was demonstrated in Figure 42. In this case, both input and output wires were over the PCB, strong coupling means that the filter was not effective at all.

Now let us look more at how wires over the PCB can radiate both internally and externally to the system. Notice that in Figure 42, on the right-hand side, there's an open frame power supply unit, again, wires were observed 'flying' over the power supply. Depending on the length of the wire, radiated emission could peak at certain frequency, as it is demonstrated: A well-designed SMPS (24Vin, 5Vout) is shown in Figure 43 with a coaxial cable over the top of it. The frame of the SMPS was deliberately left open and the length of the cable is about 1 meter long. An RF current probe was used to measure the RF current on the cable. It was found that at 100 MHz, the cable radiates efficiently. The current measured with the RF current probe peaks at the frequency at which the wire is a one half-wavelength dipole. The emission from the power supply is not large enough to radiate efficiently at 100 MHz. In fact, this SMPS passed all the relevant EMC tests. But once a nearby wire is placed close enough, the wire is long enough to radiate efficiently.





*Figure 43 Demonstration of a 'flying' wire over a power supply unit, noise was induced into the coaxial cable and radiation occurred*

The general rule is to keep the input side wiring and filter far away from other wiring (especially the output wiring). If wires must be crossed, they should be crossed perpendicular to one another. In the case of wires flying over an inductor, it should be crossed in a way that least magnetic flux is coupled.

On the board level, similar mistakes were not uncommon. In Figure 44, the designer engineers placed the filter on the PCB, only to lay out the trace before and after the filter in parallel. This means strong coupling between the two traces, degrading the filter performance.

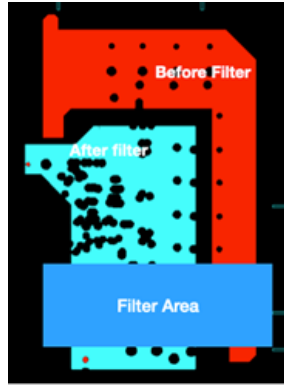

Figure 44 This layout means strong coupling between the two traces (trace before and after the filter)

Similarly, when working with big cabinet, the filter must be placed in a position where the noise cannot find the coupling path to escape. In Figure 45(a), the noise is coupled onto the wire existing the unit, negating the filter's performance. In (b), re-arrange the filter so that the coupling is minimised.

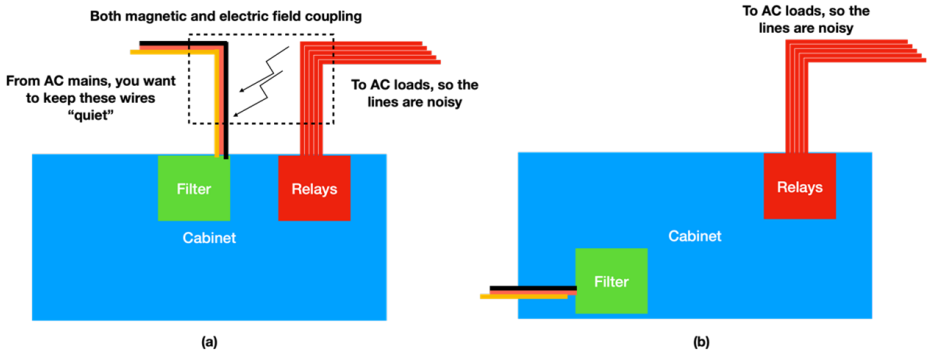

Figure 45 Filter position in the cabinet, (a) incorrect (b) correct

## 7.3 - Cost-Effective Filter Implementation

One of the challenges with filters are the cost associated with high voltage and high current filter components. When the current rating exceeds 10s of amperes, the magnetic components become costly.

One way of implementing a cost-effective filter is to utilise magnetic cores. The ferrite cores introduced previously are just one example. Of course, the core material could be nanocrystalline or others depending on the application. Figure 46 demonstrates this concept. A ferrite, together with Y-capacitors form an R-L-C filter for the common-mode noise. The great virtue of this configuration is that the core is not subjected to saturation, so it is suitable for high current application.

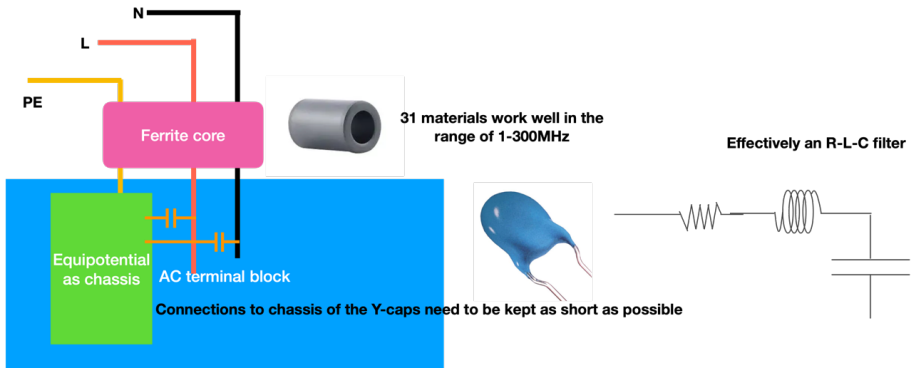

Figure 46 A low-cost filter implementation using ferrite cores and Y-capacitors

Magnetic cores are seen in many applications, such as the DC-DC converter used in Tesla electric vehicle (shown in Figure 47). The output current for this type of application often reaches beyond hundreds of amperes, any inductors on the output would be bulky, heavy and costly. Instead of placing inductors, the positive and negative rails were put on adjacent layers of the board. Depending on the current rating, often wide track or plane were used. Similar to a bifilar winding, all the magnetic field then flows in the small gap between the two planes and the only remaining flux is the high frequency common mode noise. All one needs to do then is to put a core (or multiple cores) through the board or around the board. Mechanically, this is also easy to do.

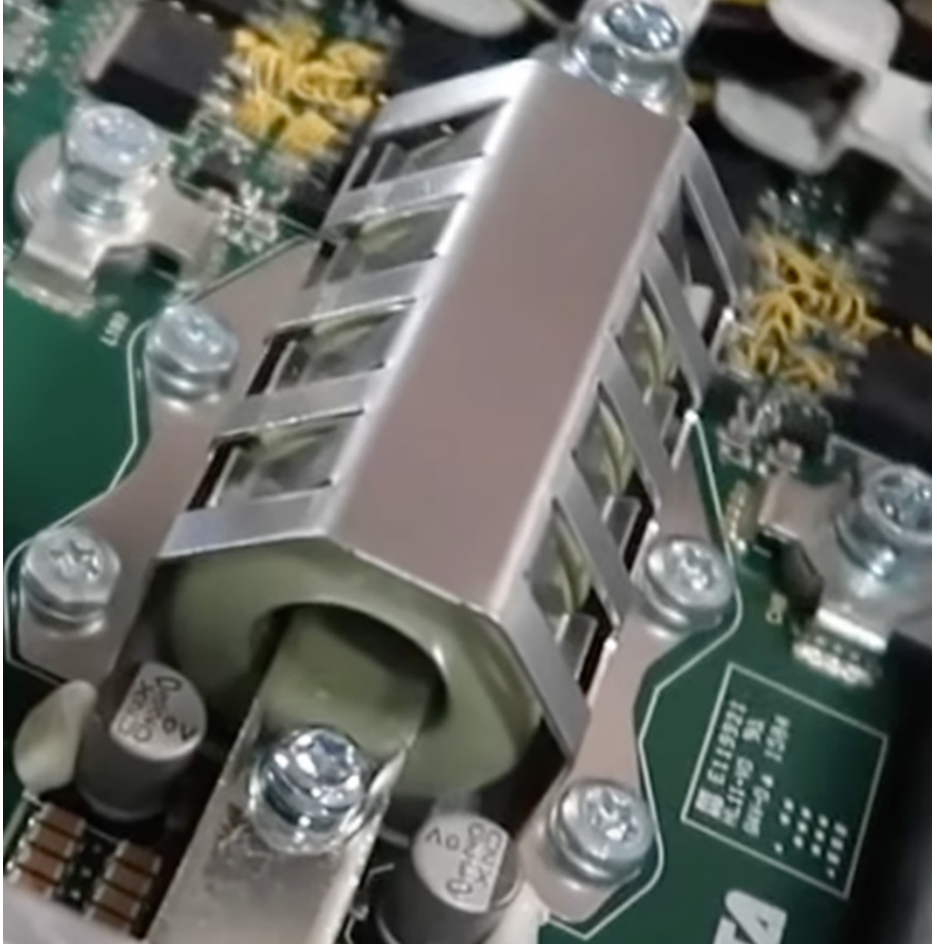

Figure 47 A DC-DC converter used in Tesla electric vehicles, multi-cores were clamped in the 12V DC output bus bar. The current rating of the output could be as high as 250 Amps

# Chapter 8

## Immunity And Other Aspects

### 8.1 - Immunity

Much of the discussion so far has focused on the emission, i.e. the noise that is generated by the product that design engineers build. Noise emanating from the outside of the product can cause immunity issues too. The most common immunity problems in the field are radiated immunity, electric fast transient (EFT) and ESD.

Thanks to reciprocity theorem which states that “if a structure radiates well, then it will also pick up energy well, and vice versa [4].” A good filter that is designed for radiated emission and functions well will also be able to stop noise (of the same spectrum) from entering the system.

Fast transient often occurs on the line when an inductive component in the same line is switched off. The inductive component could be an electric machine or a relay. The back EMF in the inductive coil will generate a big ‘kickback’ voltage. A front-end filter is therefore very useful to prevent the electric fast transient from damaging the product/system that engineers design, which is demonstrated in Figure 39. The dashed line indicates the transient voltages penetrating through the system, the solid red line shows the result when the filter is fitted in. The filter model is based on the REO CNW series, the simulation model of this filter can be found in Figure 33.

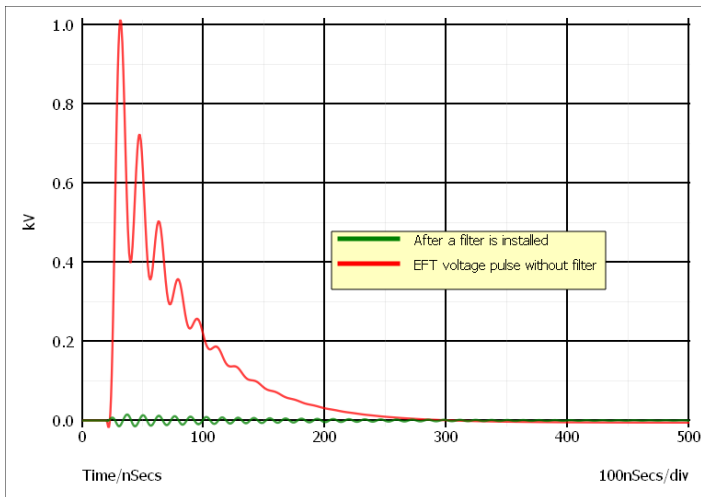

Figure 48 Front-end filters also keep fast transient noise from entering the system

The philosophy of designing a filter against immunity issues is exactly the same as designing a filter to prevent emission. A well-designed filter should work both ways. Apart from the electric characteristics of a filter, design engineers should also consider the mechanical aspects when designing a filter. A typical example is an on-board-charger used for EV application. Since the filter is now fitted into a moving product, it also needs to meet the tough automotive environmental and mechanical requirements. Check the filter manufacturer guides to make sure your filter selection meets all the requirements.

In this book, we aim to bring the first principle of EMC engineering to our readers, therefore we discussed the fundamental part of a filter in depth. We hope that design engineers, when equipped with the first principle, should be able to design a filter in the most cost-effective way that also considers the rules of EMI physics.



## Electricity Is What Makes REO Tick!



# References

- [1] [D. C. Smith, High Frequency Measurements and Noise in Electronic Circuits, New York: Van Nostrand Reinhold, 1993.](#)
- [2] [K. Armstrong, EMC for Printed Circuit Boards, Nutwood UK Ltd, 2010, ISBN:978-0-9555118-5-1.](#)
- [3] [M. Zhang, "EMC Design Techniques for Electric Vehicle Powertrain Modules," InCompliance, no. February, 2021.](#)
- [4] [Ziwei Ouyang, Jun Zhang, William Gerard Hurley, "Calculation of Leakage Inductance for High Frequency Transformers," IEEE Transactions on Power Electronics, vol. 30, no. 10, pp. 5769-5775, 2015.](#)
- [5] [R. Morrison, Fast Circuit Boards - Energy Management, Wiley, 2018.](#)
- [6] [K. Armstrong, "EMC and Safety for Installations: Part 1," 2020. \[Online\].](#)
- [7] [S. E. AG, "Leakage Currents in Power Line Filters".](#)
- [8] [T. Williams, "Using cable ferrites for interference suppression," ELMAC services.](#)
- [9] [R.C.Marshall, "A cable can be an effective antenna - so you add ferrite".](#)
- [10] [D. Smith, "Can Ferrite Cores Increase Emission?," 1999.](#)
- [11] [T. H. Hubing, EMC question of the week 2017-2020, Learn EMC, 2021.](#)
- [12] [H. W. Ott, Electromagnetic Compatibility Engineering, New Jersey: Wiley, 2009.](#)

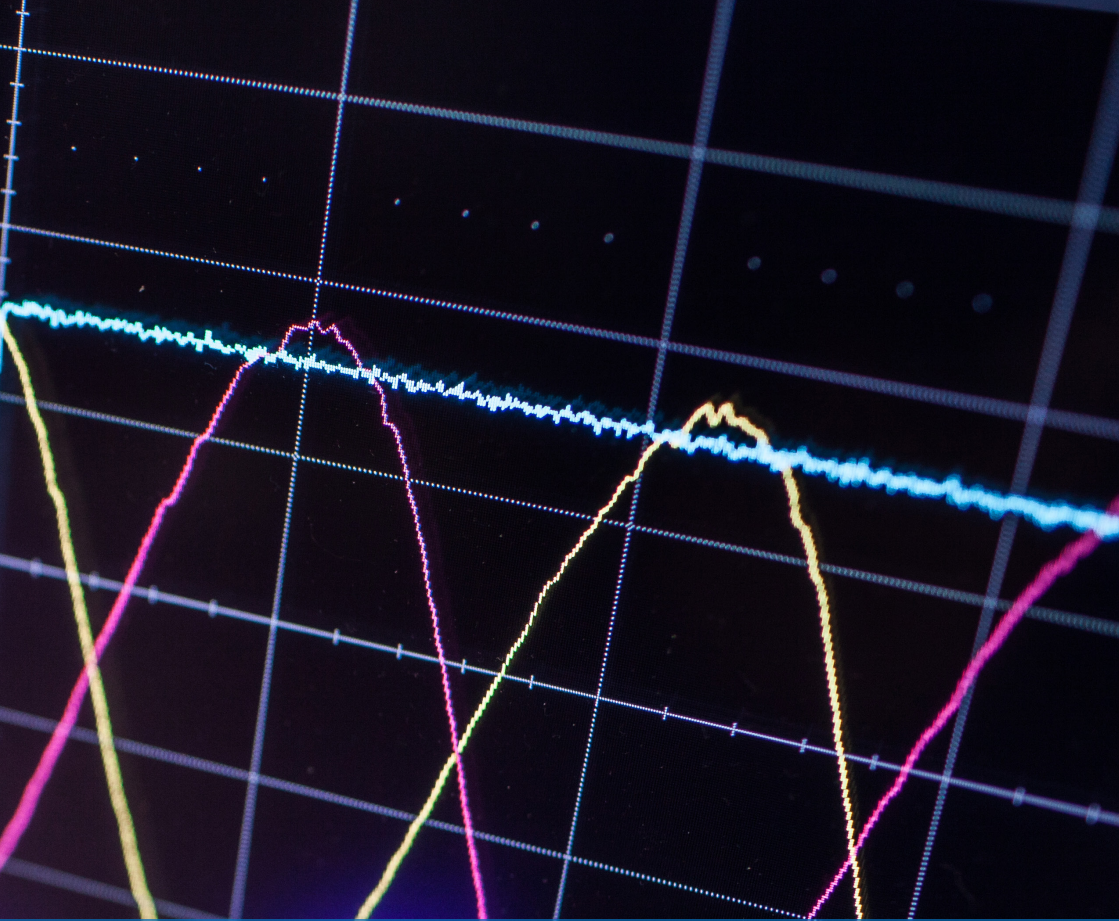

# REO

REO (UK) LTD, Units 2 – 4 Callow Hill Road, Craven Arms  
Business Park, Craven Arms, Shropshire SY7 8NT  
Tel: 01588 673411 Email: sales@reo.co.uk  
Website: www.reo.co.uk

